

Protective Relaying

Principles and Applications

Third Edition

POWER ENGINEERING

Series Editor

H. Lee Willis

*KEMA T&D Consulting
Raleigh, North Carolina*

Advisory Editor

Muhammad H. Rashid

*University of West Florida
Pensacola, Florida*

1. Power Distribution Planning Reference Book, *H. Lee Willis*
2. Transmission Network Protection: Theory and Practice, *Y. G. Paithankar*
3. Electrical Insulation in Power Systems, *N. H. Malik, A. A. Al-Arainy, and M. I. Qureshi*
4. Electrical Power Equipment Maintenance and Testing, *Paul Gill*
5. Protective Relaying: Principles and Applications, Second Edition, *J. Lewis Blackburn*
6. Understanding Electric Utilities and De-Regulation, *Lorrin Philipson and H. Lee Willis*
7. Electrical Power Cable Engineering, *William A. Thue*
8. Electric Systems, Dynamics, and Stability with Artificial Intelligence Applications, *James A. Momoh and Mohamed E. El-Hawary*
9. Insulation Coordination for Power Systems, *Andrew R. Hileman*
10. Distributed Power Generation: Planning and Evaluation, *H. Lee Willis and Walter G. Scott*
11. Electric Power System Applications of Optimization, *James A. Momoh*
12. Aging Power Delivery Infrastructures, *H. Lee Willis, Gregory V. Welch, and Randall R. Schrieber*
13. Restructured Electrical Power Systems: Operation, Trading, and Volatility, *Mohammad Shahidehpour and Muwaffaq Alomoush*
14. Electric Power Distribution Reliability, *Richard E. Brown*

15. Computer-Aided Power System Analysis, *Ramasamy Natarajan*
16. Power System Analysis: Short-Circuit Load Flow and Harmonics, *J. C. Das*
17. Power Transformers: Principles and Applications, *John J. Winders, Jr.*
18. Spatial Electric Load Forecasting: Second Edition, Revised and Expanded, *H. Lee Willis*
19. Dielectrics in Electric Fields, *Gorur G. Raju*
20. Protection Devices and Systems for High-Voltage Applications, *Vladimir Gurevich*
21. Electrical Power Cable Engineering, Second Edition, *William Thue*
22. Vehicular Electric Power Systems: Land, Sea, Air, and Space Vehicles, *Ali Emadi, Mehrdad Ehsani, and John Miller*
23. Power Distribution Planning Reference Book, Second Edition, *H. Lee Willis*
24. Power System State Estimation: Theory and Implementation, *Ali Abur*
25. Transformer Engineering: Design and Practice, *S.V. Kulkarni and S. A. Khaparde*
26. Power System Capacitors, *Ramasamy Natarajan*
27. Understanding Electric Utilities and De-regulation: Second Edition, *Lorrin Philipson and H. Lee Willis*
28. Control and Automation of Electric Power Distribution Systems, *James Northcote-Green and Robert G. Wilson*
29. Protective Relaying for Power Generation Systems, *Donald Reimert*
30. Protective Relaying: Principles and Applications, Third Edition, *J. Lewis Blackburn and Thomas J. Domin*

Protective Relaying

Principles and Applications

Third Edition

J. Lewis Blackburn
Thomas J. Domin



CRC Press

Taylor & Francis Group

Boca Raton London New York

CRC Press is an imprint of the
Taylor & Francis Group, an informa business

CRC Press
Taylor & Francis Group
6000 Broken Sound Parkway NW, Suite 300
Boca Raton, FL 33487-2742

© 2007 by Taylor & Francis Group, LLC
CRC Press is an imprint of Taylor & Francis Group, an Informa business

No claim to original U.S. Government works
Printed in the United States of America on acid-free paper
10 9 8 7 6 5 4 3 2 1

International Standard Book Number-10: 1-57444-716-5 (Hardcover)
International Standard Book Number-13: 978-1-57444-716-3 (Hardcover)

This book contains information obtained from authentic and highly regarded sources. Reprinted material is quoted with permission, and sources are indicated. A wide variety of references are listed. Reasonable efforts have been made to publish reliable data and information, but the author and the publisher cannot assume responsibility for the validity of all materials or for the consequences of their use.

No part of this book may be reprinted, reproduced, transmitted, or utilized in any form by any electronic, mechanical, or other means, now known or hereafter invented, including photocopying, microfilming, and recording, or in any information storage or retrieval system, without written permission from the publishers.

For permission to photocopy or use material electronically from this work, please access www.copyright.com (<http://www.copyright.com/>) or contact the Copyright Clearance Center, Inc. (CCC) 222 Rosewood Drive, Danvers, MA 01923, 978-750-8400. CCC is a not-for-profit organization that provides licenses and registration for a variety of users. For organizations that have been granted a photocopy license by the CCC, a separate system of payment has been arranged.

Trademark Notice: Product or corporate names may be trademarks or registered trademarks, and are used only for identification and explanation without intent to infringe.

Visit the Taylor & Francis Web site at
<http://www.taylorandfrancis.com>

and the CRC Press Web site at
<http://www.crcpress.com>

Preface to the Third Edition

The third edition of *Protective Relaying* incorporates information on new developments and topics in protective relaying that has emerged since the second edition was published. This time span represents a dynamic period that involved significant technological advances and revolutionary structural changes within the electric power industry. The format of this book remains similar to the previous editions and retains the full scope of fundamentals of protection that have been presented by Lewis Blackburn in a most elegant and understandable manner. I have taken on the task of updating and expanding Blackburn's work with humility and honor.

From a technical standpoint, significant advances in the development and application of digital processing devices in power system protection and control continue. A considerable amount of new material is presented on this subject along with the benefits and problems associated with applying such microprocessor-based devices in protection schemes. Over recent years, structural changes within the electric utility industry have changed the manner in which segments of power systems are owned and networks are developed. The impacts of these changes with respect to the system protection function are discussed in this edition. In addition, structural and regulatory changes have promoted the installation of generators with a wide range of sizes at locations that are distributed throughout power transmission and distribution systems. A discussion of protection requirements at the interconnection location for such distributed generation has been added to the text. New material is also presented on the application of protective systems and limiters in generator excitation systems. Other areas that have been added or significantly expanded include capacitor bank protection, underfrequency load-shedding scheme designs and performance, voltage collapse and mitigation, special protection schemes, fault and event recording, fault location techniques, and the latest advances in transformer protection. All existing material in the text has been reviewed and updated as appropriate.

An addition that I hope will be rewarding to the reader is the inclusion of my personal insights on the practical application and performance aspects of power system protection and operations. These perspectives have been gained during my career, spanning over 40 years, as a protection engineer at a midsized electric utility and as a consultant to various electric power entities throughout the world. Through this experience, I believe that I have gained a peek into, and an appreciation of, many of the significant issues that confront and challenge engineers attempting to develop a background and intuition in

power system protection. The insights presented are personal and practical, more than theoretical, and are intended to add a real-life perspective to the text. It is hoped that this material will help put various protection practices into a clearer perspective and provide useful information to improve the effectiveness of engineers working in the highly challenging and rewarding field of protective relaying.

Thomas J. Domin

Preface to the Second Edition

This new edition of *Protective Relaying* has been written to update and expand the treatment of many important topics in the first edition, which was published in 1987. The structure is similar to that of the first edition, but each chapter has been carefully reviewed and changes have been made throughout to clarify material, present advances in relaying for the protection of power systems, and add additional examples. The chapter on generator protection has been completely rewritten to reflect current governmental rules and regulations. Many figures are now displayed in a more compact form, which makes them easier to refer to. As in the first edition, additional problems are provided at the back of the book for further study. I have tried again to present the material in a straightforward style, focusing on what will be most useful to the reader. I hope that this volume will be as well received as the first edition was.

J. Lewis Blackburn

Preface to the First Edition

Protective relaying is a vital part of any electric power system: unnecessary during normal operation but very important during trouble, faults, and abnormal disturbances. Properly applied protective relaying initiates the disconnection of the trouble area while operation and service in the rest of the system continue.

This book presents the fundamentals and basic technology of application of protective relays in electric power systems and documents the protection practices in common use. The objective is to provide a useful reference for practicing engineers and technicians as well as a practical book for college-level courses in the power field. Applications with examples are included for both utility and industrial–commercial systems generally operating above 480 V.

Protective relay designs vary with different manufacturers and are constantly changing, especially as solid-state technology impacts this area. However, protective relaying applications remain the same: relatively independent of designs and their trends. As a result, design aspects are not emphasized in this book. This area is best covered by individual manufacturer's information.

Protective relaying can be considered a vertical specialty with a horizontal vantage point; thus, although specialized, it is involved with and requires knowledge of all of the equipment required in the generation, transmission, distribution, and utilization of electrical power. In addition, it requires an understanding of how the system performs normally as well as during faults and abnormal conditions. As a result, this subject provides an excellent background for specialized study in any of the individual areas and is especially important for system planning, operation, and management.

Friends and associates of 50 years and students within Westinghouse, the IEEE, CIGRE, many utilities, and industrial companies around the world have directly or indirectly contributed to this book. Their contributions and support are gratefully acknowledged.

Special acknowledgment and thanks are extended to Rich Duncan for his enthusiastic encouragement and support during the preparation of this manuscript and to W.A. Elmore, T.D. Estes, C.H. Griffin, R.E. Hart, C.J. Heffernan, and H.J. Li for photographic and additional technical help. In addition, I express my gratitude to Dr. Eileen Gardiner of Marcel Dekker, Inc., who most patiently encouraged and supported this effort.

J. Lewis Blackburn

Author

Thomas J. Domin is a registered professional engineer in the state of Pennsylvania with extensive experience working with electrical power systems. His work background includes over 40 years of experience in working for PPL, Inc., a mid-sized electric utility headquartered in Allentown, Pennsylvania. A major portion of this experience has been in the area of protective relaying with a major focus on the application and coordination of protective facilities on electrical power systems. The scope of his work covers electrical facilities extending from high-voltage transmission systems down through low-voltage distribution systems and includes the development of protection requirements and analysis of protection performance for power system lines, transformers, generators, capacitors, power plant auxiliary equipment, and interties with nonutility facilities. His experience includes the development of protection philosophies, standards, and practices; the specification of relaying and control logic requirements for protective systems; the development of specifications for protective relay settings; and the analysis of disturbances in electric power systems. He has also studied and analyzed generator excitation control systems, voltage control, load flow, system stability, and system operations and has worked on the development of expansion planning studies for electric utility systems. In addition to working on electrical systems within the United States, Mr. Domin has also worked on a variety of international projects involving electrical protection and power system operations.

Table of Contents

Chapter 1

Introduction and General Philosophies

- 1.1 Introduction and Definitions
- 1.2 Typical Protective Relays and Relay Systems
- 1.3 Typical Power Circuit Breakers
- 1.4 Nomenclature and Device Numbers
- 1.5 Typical Relay and Circuit Breaker Connections
- 1.6 Basic Objectives of System Protection
 - 1.6.1 Reliability
 - 1.6.2 Selectivity
 - 1.6.3 Speed
 - 1.6.4 Simplicity
 - 1.6.5 Economics
 - 1.6.6 General Summary
- 1.7 Factors Affecting the Protection System
 - 1.7.1 Economics
 - 1.7.2 Personality Factor
 - 1.7.3 Location of Disconnecting and Input Devices
 - 1.7.4 Available Fault Indicators
- 1.8 Classification of Relays
 - 1.8.1 Protective Relays
 - 1.8.2 Regulating Relays
 - 1.8.3 Reclosing, Synchronism Check, and Synchronizing Relays
 - 1.8.4 Monitoring Relays
 - 1.8.5 Auxiliary Relays
 - 1.8.6 Other Relay Classifications
- 1.9 Protective Relay Performance
 - 1.9.1 Correct Operation
 - 1.9.2 Incorrect Operation
 - 1.9.3 No Conclusion
- 1.10 Principles of Relay Application
- 1.11 Information for Application
 - 1.11.1 System Configuration
 - 1.11.2 Impedance and Connection of the Power Equipment, System Frequency, System Voltage, and System Phase Sequence

- 1.11.3 Existing Protection and Problems
 - 1.11.4 Operating Procedures and Practices
 - 1.11.5 Importance of the System Equipment Being Protected
 - 1.11.6 System Fault Study
 - 1.11.7 Maximum Loads and System Swing Limits
 - 1.11.8 Current and Voltage Transformer Locations, Connections, and Ratios
 - 1.11.9 Future Expansion
 - 1.12 Structural Changes within the Electric Power Industry
 - 1.13 Reliability and Protection Standards
- Bibliography

Chapter 2

Fundamental Units: Per Unit and Percent Values

- 2.1 Introduction
- 2.2 Per Unit and Percent Definitions
- 2.3 Advantages of Per Unit and Percent
- 2.4 General Relations between Circuit Quantities
- 2.5 Base Quantities
- 2.6 Per Unit and Percent Impedance Relations
- 2.7 Per Unit and Percent Impedances of Transformer Units
 - 2.7.1 Transformer Bank Example
- 2.8 Per Unit and Percent Impedances of Generators
- 2.9 Per Unit and Percent Impedances of Overhead Lines
- 2.10 Changing Per Unit (Percent) Quantities to Different Bases
 - 2.10.1 Example: Base Conversion with Equation 2.34
 - 2.10.2 Example: Base Conversion Requiring Equation 2.33

Bibliography

Chapter 3

Phasors and Polarity

- 3.1 Introduction
- 3.2 Phasors
 - 3.2.1 Phasor Representation
 - 3.2.2 Phasor Diagrams for Sinusoidal Quantities
 - 3.2.3 Combining Phasors
 - 3.2.4 Phasor Diagrams Require a Circuit Diagram
 - 3.2.5 Nomenclature for Current and Voltage
 - 3.2.5.1 Current and Flux
 - 3.2.5.2 Voltage
 - 3.2.6 Phasor Diagram
- 3.3 Circuit and Phasor Diagrams for a Balanced Three-Phase Power System

- 3.4 Phasor and Phase Rotation
- 3.5 Polarity
 - 3.5.1 Transformer Polarity
 - 3.5.2 Relay Polarity
- 3.6 Application of Polarity for Phase-Fault Directional Sensing
 - 3.6.1 90° – 60° Connection for Phase-Fault Protection
- 3.7 Directional Sensing for Ground Faults: Voltage Polarization
- 3.8 Directional Sensing for Ground Faults: Current Polarization
- 3.9 Other Directional-Sensing Connections
- 3.10 Application Aspects of Directional Relaying
- 3.11 Summary

Chapter 4

Symmetrical Components: A Review

- 4.1 Introduction and Background
- 4.2 Positive-Sequence Set
- 4.3 Nomenclature Convenience
- 4.4 Negative-Sequence Set
- 4.5 Zero-Sequence Set
- 4.6 General Equations
- 4.7 Sequence Independence
- 4.8 Positive-Sequence Sources
- 4.9 Sequence Networks
 - 4.9.1 Positive-Sequence Network
 - 4.9.2 Negative-Sequence Network
 - 4.9.3 Zero-Sequence Network
 - 4.9.4 Sequence Network Reduction
- 4.10 Shunt Unbalance Sequence Network Interconnections
 - 4.10.1 Fault Impedance
 - 4.10.2 Substation and Tower-Footing Impedance
 - 4.10.3 Sequence Interconnections for Three-Phase Faults
 - 4.10.4 Sequence Interconnections for Single-Phase-to-Ground Faults
 - 4.10.5 Sequence Interconnections for Phase-to-Phase Faults
 - 4.10.6 Sequence Interconnections for Double-Phase-to-Ground Faults
 - 4.10.7 Other Sequence Interconnections for Shunt System Conditions
- 4.11 Example: Fault Calculations on a Typical System Shown in Figure 4.16
 - 4.11.1 Three-Phase Fault at Bus G
 - 4.11.2 Single-Phase-to-Ground Fault at Bus G
- 4.12 Example: Fault Calculation for Autotransformers
 - 4.12.1 Single-Phase-to-Ground Fault at H Calculation

- 4.13 Example: Open-Phase Conductor
- 4.14 Example: Open Phase Falling to Ground on One Side
- 4.15 Series and Simultaneous Unbalances
- 4.16 Overview
 - 4.16.1 Voltage and Current Phasors for Shunt Faults
 - 4.16.2 System Voltage Profiles during Faults
 - 4.16.3 Unbalanced Currents in the Unfaulted Phases for Phase-to-Ground Faults in Loop Systems
 - 4.16.4 Voltage and Current Fault Phasors for All Combinations of the Different Faults
- 4.17 Summary
- Bibliography
- Appendix 4.1 Short-Circuit MVA and Equivalent Impedance
- Appendix 4.2 Impedance and Sequence Connections for Transformer Banks
- Appendix 4.3 Sequence Phase Shifts through Wye–Delta Transformer Banks

Chapter 5

Relay Input Sources

- 5.1 Introduction
- 5.2 Equivalent Circuits of Current and Voltage Transformers
- 5.3 Current Transformers for Protection Applications
- 5.4 Current Transformer Performance on a Symmetrical AC Component
 - 5.4.1 Performance by Classic Analysis
 - 5.4.2 Performance by CT Characteristic Curves
 - 5.4.3 Performance by ANSI/IEEE Standard Accuracy Classes
 - 5.4.4 IEC Standard Accuracy Classes
- 5.5 Secondary Burdens during Faults
- 5.6 CT Selection and Performance Evaluation for Phase Faults
 - 5.6.1 CT Ratio Selection for Phase-Connected Equipment
 - 5.6.2 Select the Relay Tap for the Phase-Overcurrent Relays
 - 5.6.3 Determine the Total Connected Secondary Load (Burden) in Ohms
 - 5.6.4 Determine the CT Performance Using the ANSI/IEEE Standard
 - 5.6.4.1 When Using a Class T CT
 - 5.6.4.2 When Using a Class C CT and Performance by the ANSI/IEEE Standard
 - 5.6.4.3 When Using a Class C CT and Performance with the CT Excitation Curves

- 5.7 Performance Evaluation for Ground Relays
 - 5.8 Effect of Unenergized CTs on Performance
 - 5.9 Flux Summation Current Transformer
 - 5.10 Current Transformer Performance on the DC Component
 - 5.11 Summary: Current Transformer Performance Evaluation
 - 5.11.1 Saturation on Symmetrical AC Current Input Resulting from the CT Characteristics and the Secondary Load
 - 5.11.2 Saturation by the DC Offset of the Primary AC Current
 - 5.12 Current Transformer Residual Flux and Subsidence Transients
 - 5.13 Auxiliary Current Transformers in CT Secondary Circuits
 - 5.14 Voltage Transformers for Protective Applications
 - 5.15 Optical Sensors
- Bibliography

Chapter 6

Protection Fundamentals and Basic Design Principles

- 6.1 Introduction
- 6.2 Differential Principle
- 6.3 Overcurrent-Distance Protection and the Basic Protection Problem
 - 6.3.1 Time Solution
 - 6.3.2 Communication Solution
- 6.4 Backup Protection: Remote vs. Local
- 6.5 Basic Design Principles
 - 6.5.1 Time-Overcurrent Relays
 - 6.5.2 Instantaneous Current-Voltage Relays
 - 6.5.3 Directional-Sensing Power Relays
 - 6.5.4 Polar Unit
 - 6.5.5 Phase Distance Relays
 - 6.5.5.1 Balanced Beam Type: Impedance Characteristic
 - 6.5.6 R - X Diagram
 - 6.5.7 MHO Characteristic
 - 6.5.8 Single-Phase MHO Units
 - 6.5.9 Polyphase MHO Units
 - 6.5.9.1 Three-Phase Fault Units
 - 6.5.9.2 Phase-to-Phase Fault Units
 - 6.5.10 Other MHO Units
 - 6.5.11 Reactance Units
- 6.6 Ground Distance Relays

- 6.7 Solid-State Microprocessor Relays
- 6.8 Summary
- Bibliography

Chapter 7

System-Grounding Principles

- 7.1 Introduction
- 7.2 Ungrounded Systems
- 7.3 Transient Overvoltages
- 7.4 Grounded-Detection Methods for Ungrounded Systems
 - 7.4.1 Three-Voltage Transformers
 - 7.4.2 Single-Voltage Transformers
- 7.5 High-Impedance-Grounding Systems
 - 7.5.1 Resonant Grounding
 - 7.5.2 High-Resistance Grounding
 - 7.5.3 Example: Typical High-Resistance Neutral Grounding
 - 7.5.4 Example: Typical High-Resistance Grounding with Three Distribution Transformers
- 7.6 System Grounding for Mine or Other Hazardous-Type Applications
- 7.7 Low-Impedance Grounding
 - 7.7.1 Example: Typical Low-Resistance Neutral Reactor Grounding
 - 7.7.2 Example: Typical Low-Resistance Neutral Resistance Grounding
- 7.8 Solid (Effective) Grounding
 - 7.8.1 Example: Solid Grounding
 - 7.8.2 Ground Detection on Solid-Grounded Systems
- 7.9 Ferroresonance in Three-Phase Power Systems
 - 7.9.1 General Summary for Ferroresonance for Distribution Systems
 - 7.9.2 Ferroresonance at High Voltages
- 7.10 Safety Grounding
- 7.11 Grounding Summary and Recommendations
- Bibliography

Chapter 8

Generator Protection/Inertia Protection for Distributed Generation

- 8.1 Introduction
 - 8.1.1 Historical Perspectives
 - 8.1.2 Bulk Power Generators
 - 8.1.3 Distributed Generators
 - 8.1.4 Potential Problems

- 8.2 Generator Connections and Overview of Typical Protection
- 8.3 Stator Phase-Fault Protection for All Size Generators
 - 8.3.1 Differential Protection (87) for Small kVA (MVA) Generators
 - 8.3.2 Multi-CT Differential Protection (87) for All Size Generators
 - 8.3.3 High-Impedance Voltage Differential Protection for Generators
 - 8.3.4 Direct-Connected Generator Current Differential Example
 - 8.3.5 Phase Protection for Small Generators That Do Not Use Differentials
 - 8.3.6 Unit Generator Current Differential (87) Example for Phase Protection
- 8.4 Unit Transformer Phase-Fault Differential Protection (87TG)
- 8.5 Phase-Fault Backup Protection (51 V) or (21)
 - 8.5.1 Voltage-Controlled or Voltage-Restraint Time-Overcurrent (51 V) Backup Protection
 - 8.5.2 Phase-Distance (21) Backup Protection
- 8.6 Negative-Sequence Current Backup Protection
- 8.7 Stator Ground-Fault Protection
 - 8.7.1 Ground-Fault Protection for Single Medium or Small Wye-Connected Generators
 - 8.7.2 Ground-Fault Protection of Multiple Medium or Small Wye- or Delta-Connected Generators
 - 8.7.3 Ground-Fault Protection for Ungrounded Generators
 - 8.7.4 Ground-Fault Protection for Very Small, Solidly Grounded Generators
 - 8.7.5 Ground-Fault Protection for Unit-Connected Generators Using High-Impedance Neutral Grounding
 - 8.7.6 Added Protection for 100% Generator Ground Protection with High-Resistance Grounding
 - 8.7.7 High-Voltage Ground-Fault Coupling Can Produce V_0 in High-Impedance-Grounding Systems
 - 8.7.8 Ground-Fault Protection for Multidirect-Connected Generators Using High-Resistance Grounding
- 8.8 Multiple Generator Units Connected Directly to a Transformer: Grounding and Protection
- 8.9 Field Ground Protection (64)
- 8.10 Generator Off-Line Protection
- 8.11 Reduced or Lost Excitation Protection (40)
 - 8.11.1 Loss of Excitation Protection with Distance (21) Relays
 - 8.11.2 Loss of Excitation Protection with a Var-Type Relay

- 8.12 Generator Protection for System Disturbances and Operational Hazards
 - 8.12.1 Loss of Prime-Mover: Generator Motoring (32)
 - 8.12.2 Overexcitation: Volts per Hertz Protection (24)
 - 8.12.3 Inadvertent Energization: Nonsynchronized Connection (67)
 - 8.12.4 Breaker Pole Flashover (61)
 - 8.12.5 Thermal Overload (49)
 - 8.12.6 Off-Frequency Operation
 - 8.12.7 Overvoltage
 - 8.12.8 Loss of Synchronism: Out-of-Step
 - 8.12.9 Subsynchronous Oscillations
 - 8.13 Loss of Voltage Transformer Signal
 - 8.14 Generator Breaker Failure
 - 8.15 Excitation System Protection and Limiters
 - 8.15.1 Field Grounds
 - 8.15.2 Field Overexcitation
 - 8.15.3 Field Underexcitation
 - 8.15.4 Practical Considerations
 - 8.16 Synchronous Condenser Protection
 - 8.17 Generator-Tripping Systems
 - 8.18 Station Auxiliary Service System
 - 8.19 Distributed Generator Intertie Protection
 - 8.19.1 Power Quality Protection
 - 8.19.2 Power System Fault Protection
 - 8.19.3 System Protection for Faults on Distributed Generator Facilities
 - 8.19.4 Other Intertie Protection Considerations
 - 8.19.5 Induction Generators
 - 8.19.6 Practical Considerations of Distributed Generation
 - 8.20 Protection Summary
- Bibliography

Chapter 9

Transformer, Reactor, and Shunt Capacitor Protection

- 9.1 Transformers
- 9.2 Factors Affecting Differential Protection
- 9.3 False Differential Current
 - 9.3.1 Magnetization Inrush
 - 9.3.2 Overexcitation
 - 9.3.3 Current Transformer Saturation
- 9.4 Transformer Differential Relay Characteristics
- 9.5 Application and Connection of Transformer Differential Relays

- 9.6 Example: Differential Protection Connections for a Two-Winding Wye–Delta Transformer Bank
 - 9.6.1 First Step: Phasing
 - 9.6.2 Second Step: CT Ratio and Tap Selections
- 9.7 Load Tap-Changing Transformers
- 9.8 Example: Differential Protection Connections for Multiwinding Transformer Bank
- 9.9 Application of Auxiliaries for Current Balancing
- 9.10 Paralleling CTs in Differential Circuits
- 9.11 Special Connections for Transformer Differential Relays
- 9.12 Differential Protection for Three-Phase Banks of Single-Phase Transformer Units
- 9.13 Ground (Zero-Sequence) Differential Protection for Transformers
- 9.14 Equipment for Transfer Trip Systems
 - 9.14.1 Fault Switch
 - 9.14.2 Communication Channel
 - 9.14.3 Limited Fault-Interruption Device
- 9.15 Mechanical Fault-Detection for Transformers
 - 9.15.1 Gas Detection
 - 9.15.2 Sudden Pressure
- 9.16 Grounding Transformer Protection
- 9.17 Ground Differential Protection with Directional Relays
- 9.18 Protection of Regulating Transformers
- 9.19 Transformer Overcurrent Protection
- 9.20 Transformer Overload-Through-Fault-Withstand Standards
- 9.21 Examples: Transformer Overcurrent Protection
 - 9.21.1 An Industrial Plant or Similar Facility Served by a 2500 kVA, 12 kV: 480 V Transformer with 5.75% Impedance
 - 9.21.2 A Distribution or Similar Facility Served by a 7500 kVA, 115: 12 kV Transformer with 7.8% Impedance
 - 9.21.3 A Substation Served by a 12/16/20 MVA, 115: 12.5 kV Transformer with 10% Impedance
- 9.22 Transformer Thermal Protection
- 9.23 Overvoltage on Transformers
- 9.24 Summary: Typical Protection for Transformers
 - 9.24.1 Individual Transformer Units
 - 9.24.2 Parallel Transformer Units

- 9.24.3 Redundancy Requirements for Bulk Power Transformers
- 9.25 Reactors
 - 9.25.1 Types of Reactors
 - 9.25.2 General Application of Shunt Reactors
 - 9.25.3 Reactor Protection
- 9.26 Capacitors
- 9.27 Power System Reactive Requirements
- 9.28 Shunt Capacitor Applications
- 9.29 Capacitor Bank Designs
- 9.30 Distribution Capacitor Bank Protection
- 9.31 Designs and Limitations of Large Capacitor Banks
- 9.32 Protection of Large Capacitor Banks
- 9.33 Series Capacitor Bank Protection
- 9.34 Capacitor Bank Protection Application Issues
- Bibliography

Chapter 10

Bus Protection

- 10.1 Introduction: Typical Bus Arrangements
- 10.2 Single Breaker–Single Bus
- 10.3 Single Buses Connected with Bus Ties
- 10.4 Main and Transfer Buses with Single Breakers
- 10.5 Single Breaker–Double Bus
- 10.6 Double Breaker–Double Bus
- 10.7 Ring Bus
- 10.8 Breaker-and-Half Bus
- 10.9 Transformer–Bus Combination
- 10.10 General Summary of Buses
- 10.11 Differential Protection for Buses
 - 10.11.1 Multirestraint Current Differential
 - 10.11.2 High-Impedance Voltage Differential
 - 10.11.3 Air-Core Transformer Differential
 - 10.11.4 Moderate High-Impedance Differential
- 10.12 Other Bus Differential Systems
 - 10.12.1 Time–Overcurrent Differential
 - 10.12.2 Directional Comparison Differential
 - 10.12.3 Partial Differential
 - 10.12.4 Short Time Delay Scheme—Instantaneous Blocking
- 10.13 Ground-Fault Bus
- 10.14 Protection Summary
- 10.15 Bus Protection—Practical Considerations
- Bibliography

Chapter 11

Motor Protection

- 11.1 Introduction
- 11.2 Potential Motor Hazards
- 11.3 Motor Characteristics Involved in Protection
- 11.4 Induction Motor Equivalent Circuit
- 11.5 General Motor Protection
- 11.6 Phase-Fault Protection
- 11.7 Differential Protection
- 11.8 Ground-Fault Protection
- 11.9 Thermal and Locked-Rotor Protection
- 11.10 Locked-Rotor Protection for Large Motors (21)
- 11.11 System Unbalance and Motors
- 11.12 Unbalance and Phase Rotation Protection
- 11.13 Undervoltage Protection
- 11.14 Bus Transfer and Reclosing
- 11.15 Repetitive Starts and Jogging Protection
- 11.16 Multifunction Microprocessor Motor Protection Units
- 11.17 Synchronous Motor Protection
- 11.18 Summary: Typical Protection for Motors
- 11.19 Practical Considerations of Motor Protection

Bibliography

Chapter 12

Line Protection

- 12.1 Classifications of Lines and Feeders
- 12.2 Line Classifications for Protection
 - 12.2.1 Distribution Lines
 - 12.2.2 Transmission and Subtransmission Lines
- 12.3 Techniques and Equipment for Line Protection
 - 12.3.1 Fuses
 - 12.3.2 Automatic Circuit Reclosers
 - 12.3.3 Sectionalizers
 - 12.3.4 Coordinating Time Interval
- 12.4 Coordination Fundamentals and General Setting Criteria
 - 12.4.1 Phase Time–Overcurrent Relay Setting
 - 12.4.2 Ground Time–Overcurrent Relay Setting
 - 12.4.3 Phase and Ground Instantaneous Overcurrent Relay Setting
- 12.5 Distribution Feeder, Radial Line Protection, and Coordination
- 12.6 Example: Coordination for a Typical Distribution Feeder
 - 12.6.1 Practical Distribution Coordination Considerations

- 12.7 Distributed Generators and Other Sources Connected to Distribution Lines
 - 12.8 Example: Coordination for a Loop System
 - 12.9 Instantaneous Trip Application for a Loop System
 - 12.10 Short-Line Applications
 - 12.11 Network and Spot Network Systems
 - 12.12 Distance Protection for Phase Faults
 - 12.13 Distance Relay Applications for Tapped and Multiterminal Lines
 - 12.14 Voltage Sources for Distance Relays
 - 12.15 Distance Relay Applications in Systems Protected by Inverse-Time–Overcurrent Relays
 - 12.16 Ground-Fault Protection for Lines
 - 12.17 Distance Protection for Ground Faults and Direction Overcurrent Comparisons
 - 12.18 Fault Resistance and Relaying
 - 12.19 Directional Sensing for Ground–Overcurrent Relays
 - 12.20 Polarizing Problems with Autotransformers
 - 12.21 Voltage Polarization Limitations
 - 12.22 Dual Polarization for Ground Relaying
 - 12.23 Ground Directional Sensing with Negative Sequence
 - 12.24 Mutual Coupling and Ground Relaying
 - 12.25 Ground Distance Relaying with Mutual Induction
 - 12.26 Long EHV Series-Compensated Line Protection
 - 12.27 Backup: Remote, Local, and Breaker Failure
 - 12.28 Summary: Typical Protection for Lines
 - 12.29 Practical Considerations of Line Protection
- Bibliography

Chapter 13

Pilot Protection

- 13.1 Introduction
- 13.2 Pilot System Classifications
- 13.3 Protection Channel Classifications
- 13.4 Directional Comparison Blocking Pilot Systems
- 13.5 Directional Comparison Unblocking Pilot System
 - 13.5.1 Normal-Operating Condition (No Faults)
 - 13.5.2 Channel Failure
 - 13.5.3 External Fault on Bus G or in the System to the Left
 - 13.5.4 Internal Faults in the Protected Zone

- 13.6 Directional Comparison Overreaching Transfer Trip Pilot Systems
 - 13.6.1 External Fault on Bus G or in the System to the Left
 - 13.6.2 Internal Faults in the Protected Zone
- 13.7 Directional Comparison Underreaching Transfer Trip Pilot Systems
 - 13.7.1 Zone Acceleration
- 13.8 Phase Comparison: Pilot Wire Relaying–Wire-Line Channels
- 13.9 Phase Comparison: Audio Tone or Fiber-Optic Channels
 - 13.9.1 External Fault on Bus H or in the System to the Right
 - 13.9.2 Internal Faults in the Protected Zone
- 13.10 Segregated Phase Comparison Pilot Systems
- 13.11 Single-Pole–Selective-Pole Pilot Systems
- 13.12 Directional Wave Comparison Systems
- 13.13 Digital Current Differential
- 13.14 Pilot Scheme Enhancements
 - 13.14.1 Transient Blocking
 - 13.14.2 Weak Infeed Logic
 - 13.14.3 “Breaker Open” Keying
- 13.15 Transfer Trip Systems
- 13.16 Communication Channels for Protection
 - 13.16.1 Power-Line Carrier: On–Off or Frequency-Shift
 - 13.16.2 Pilot Wires: Audio Tone Transmission
 - 13.16.3 Pilot Wires: 50 or 60 Hz Transmission
 - 13.16.4 Digital Channels
- 13.17 Summary and General Evaluation of Pilot Systems
- 13.18 Pilot Relaying—Operating Experiences
- Bibliography
- Appendix 13.1 Protection of Wire-Line Pilot Circuits

Chapter 14

Stability, Reclosing, Load Shedding, and Trip Circuit Design

- 14.1 Introduction
- 14.2 Electric Power and Power Transmission
- 14.3 Steady-State Operation and Stability
- 14.4 Transient Operation and Stability
- 14.5 System Swings and Protection
- 14.6 Out-of-Step Detection by Distance Relays
- 14.7 Automatic Line Reclosing
- 14.8 Distribution Feeder Reclosing
- 14.9 Subtransmission and Transmission-Line Reclosing

- 14.10 Reclosing on Lines with Transformers or Reactors
 - 14.11 Automatic Synchronizing
 - 14.12 Frequency Relaying for Load Shedding—Load Saving
 - 14.13 Underfrequency Load Shedding Design
 - 14.13.1 Underfrequency Load Shedding Criteria
 - 14.13.2 Underfrequency Load Shedding Scheme Architecture
 - 14.13.3 Underfrequency Control Scheme Design
 - 14.14 Performance of Underfrequency Load Shedding Schemes
 - 14.15 Frequency Relaying for Industrial Systems
 - 14.16 Voltage Collapse
 - 14.17 Voltage Collapse Mitigating Techniques
 - 14.18 Protection and Control Trip Circuits
 - 14.19 Substation DC Systems
 - 14.20 Trip Circuit Devices
 - 14.20.1 Auxiliary Relays
 - 14.20.2 Targeting and Seal-In Devices
 - 14.20.3 Switches and Diodes
 - 14.20.4 Trip Coils
 - 14.21 Trip Circuit Design
 - 14.22 Trip Circuit Monitoring and Alarms
 - 14.23 Special Protection Schemes
 - 14.24 Practical Considerations—Special Protection Schemes
- Bibliography

Chapter 15

Microprocessor Applications and Substation Automation

- 15.1 Introduction
- 15.2 Microprocessor-Based Relay Designs
- 15.3 Programmable Logic Controllers
- 15.4 Application of Microprocessor Relays
- 15.5 Programming of Microprocessor Relaying
 - 15.5.1 Boolean Algebra
 - 15.5.2 Control Equation Elements
 - 15.5.3 Binary Elements
 - 15.5.4 Analog Quantities
 - 15.5.5 Math Operators
 - 15.5.6 Settings
- 15.6 Attributes of Microprocessor-Based Relays
- 15.7 Protection Enhancements
 - 15.7.1 Distribution Protection Systems
 - 15.7.2 Transmission Protection Systems
- 15.8 Multifunctional Capability

- 15.9 Wiring Simplification
 - 15.10 Event Reports
 - 15.10.1 Types of Event Reports
 - 15.11 Commissioning and Periodic Testing
 - 15.12 Setting Specifications and Documentation
 - 15.13 Fault Location
 - 15.14 Power System Automation
 - 15.15 Practical Observations—Microprocessor Relay Application
- Bibliography

Problems

1 Introduction and General Philosophies

1.1 INTRODUCTION AND DEFINITIONS

What is a relay; more specifically, what is a protective relay? The Institute of Electrical and Electronic Engineers (IEEE) defines a *relay* as “an electric device that is designed to respond to input conditions in a prescribed manner and, after specified conditions are met, to cause contact operation or similar abrupt change in associated electric control circuits.” A note adds: “Inputs are usually electric, but may be mechanical, thermal, or other quantities or a combination of quantities. Limit switches and similar simple devices are not relays” (IEEE C37.90).

Relays are used in all aspects of activity: home, communication, transportation, commerce, and industry, to name a few. Wherever electricity is used, there is a high probability that relays are involved. They are used in heating, air conditioning, stoves, dishwashers, clothes washers and dryers, elevators, telephone networks, traffic controls, transportation vehicles, automatic process systems, robotics, space activities, and many other applications.

In this book we focus on one of the more interesting and sophisticated applications of relays, the protection of electric power systems. The IEEE defines a *protective relay* as “a relay whose function is to detect defective lines or apparatus or other power system conditions of an abnormal or dangerous nature and to initiate appropriate control circuit action” (IEEE 100).

Fuses are also used in protection. IEEE defines a *fuse* as “an over-current protective device with a circuit-opening fusible part that is heated and severed by the passage of the overcurrent through it” (IEEE 100).

Thus, protective relays and their associated equipment are compact units of analog, discrete solid-state components, operational amplifiers, and digital microprocessor networks connected to the power system to sense problems. These are frequently abbreviated simply as relays and relay systems. They are used in all parts of the power system, together with fuses, for the detection of intolerable conditions, most often faults.

Protective relaying, commonly abbreviated as relaying, is a non-profit, nonrevenue-producing item that is not necessary in the normal operation of an electrical power system until a fault—an abnormal, intolerable situation—occurs.

A primary objective of all power systems is to maintain a very high level of continuity of service, and when intolerable conditions occur, to minimize the extent and time of the outage. Loss of power, voltage dips, and over-voltages will occur, however, because it is impossible, as well as impractical, to avoid the consequences of natural events, physical accidents, equipment failure, or misoperation owing to human error. Many of these result in faults: inadvertent, accidental connections, and flashovers between the phase wires or from the phase wires to ground.

Natural events that can cause short circuits (faults) are lightning (induced voltage or direct strikes), wind, ice, earthquake, fire, explosions, falling trees, flying objects, physical contact by animals, and contamination. Accidents include faults resulting from vehicles hitting poles or contacting live equipment, unfortunate people contacting live equipment, digging into underground cables, human errors, and so on. Considerable effort is made to minimize damage possibilities, but the elimination of all such problems is not yet achievable.

A dramatic illustration of the need and importance of power system protection is shown in Figure 1.1. This spectacular lightning strike occurred over Seattle during a storm on July 31, 1984, and in a region where lightning



FIGURE 1.1 Lightning over Seattle—a vivid illustration of the importance of power system protection. (Greg Gilbert/Seattle Times photo.)

is infrequent. The isokeraunic charts for this area of the Pacific Northwest indicate that the probability of storm days when thunder is heard is five or fewer per year (Westinghouse Electric Corp., 1964). Although some 12,000 homes lost power during this storm, neither major damage nor prolonged outages were experienced by the local utilities. Fortunately, lightning protection and many relays operated to minimize the problems.

Good maintenance practices serve as an important tool in preventing faults and related outages. In agricultural and coastal areas, contamination on insulators caused by materials such as dust, pesticide and fertilizer sprays, and salt can build to a point that flashover occurs. Once a flashover occurs across an insulator, the circuit must be tripped in order to de-energize the arc. Flashed insulators are often damaged resulting in a permanent outage to the associated circuit. In areas where insulation contamination is prevalent, periodic cleaning of the insulators serves as a method to remove the contamination before it reaches the point of causing the insulator to flash. In recent years, raptor droppings in some northwestern states have caused insulators to fail on several important high voltage lines. Contamination caused by birds has also been a serious problem in Florida. Devices that discourage or prevent birds from roosting near or above insulators are available to mitigate this problem. A good tree-trimming programme is also an important method of preventing “tree” related faults. Broken branches and falling trees cause many outages to lines during wind, ice, and snow storms. Trees are especially problematic in distribution circuits that often run through areas that are densely populated with trees. Trees also cause problems to higher voltage transmission lines. Trees growing in the right-of-way under high voltage lines are especially troublesome as they are most likely to fault the line during heavy load periods. During such operating conditions, the power system is highly dependent on its transmission facilities in order to maintain proper operation. During heavy load periods, transmission circuits often become heavily loaded, causing the wires to heat, expand, and consequently sag. The initial contact with a tree growing beneath the circuit is, therefore, most likely to occur when the power system can least afford the loss of a line. Such tree-related contacts played a large role in two large-scale outages that blacked out a large portion of the western United States in the late 1990s. Line outages caused by tree contacts also played a part in the blackout that occurred in the northeastern part of the country in August 2003.

Most faults in an electrical utility system with a network of overhead lines are one-phase-to-ground faults resulting primarily from lightning-induced transient high voltage and from falling trees and tree limbs. In the overhead distribution systems, momentary tree contact caused by wind is another major cause of faults. Ice, freezing snow, and wind during severe storms can cause

many faults and much damage. These faults include the following, with very approximate percentages of occurrence:

- Single phase-to-ground: 70%–80%
- Phase-to-phase-to ground: 17%–10%
- Phase-to-phase: 10%–8%
- Three-phase: 3%–2%

Series unbalances, such as a broken conductor or a blown fuse, are not too common, except perhaps in the lower-voltage system in which fuses are used for protection.

Fault occurrence can be quite variable, depending on the type of power system (e.g., overhead vs. underground lines) and the local natural or weather conditions.

In many instances the flashover caused by such events does not result in permanent damage if the circuit is interrupted quickly. A common practice is to open the faulted circuit, permit the arc to extinguish naturally, and then close the circuit again. Usually, this enhances the continuity of services by causing only a momentary outage and voltage dip. Typical outage times are in the order of 0.5 to 1 or 2 min, rather than many minutes and hours.

System faults usually, but not always, provide significant changes in the system quantities, which can be used to distinguish between tolerable and intolerable system conditions. These changing quantities include overcurrent, over- or undervoltage power, power factor or phase angle, power or current direction, impedance, frequency, temperature, physical movements, pressure, and contamination of the insulating quantities. The most common fault indicator is a sudden and generally significant increase in the current; consequently, overcurrent protection is widely used.

Protection is the science, skill, and art of applying and setting relays or fuses, or both, to provide maximum sensitivity to faults and undesirable conditions, but to avoid their operation under all permissible or tolerable conditions. The basic approach throughout this book is to define the tolerable and intolerable conditions that may exist and to look for defined differences (“handles”) that the relays or fuses can sense.

It is important to recognize that the “time window” of decision in a power system’s protection is very narrow, and when faults occur, a recheck for verification or a decision-making procedure that involves additional time, is not desirable. It is vital (1) that a correct decision be made by the protective device as to whether the trouble is intolerable and, thus, demands quick action, or whether it is a tolerable or transient situation that the system can absorb, and (2) that, if necessary, the protective device operates to isolate the trouble area quickly and with a minimum of system disturbance. This trouble time may be, and often is, associated with high extraneous “noise,” which must not “fool” the device or cause incorrect operation.

Both failure to operate and incorrect operation can result in major system upsets involving increased equipment damage, increased personnel hazards, and possible long interruption of service. These stringent requirements with serious potential consequences tend to make protection engineers somewhat conservative. One of the advantages of the modern solid-state relays is that they can check and monitor themselves to minimize equipment problems as well as to provide information on the events that resulted in triggering their operation.

Problems can and do occur in protective equipment; nothing is perfect. To minimize the potential catastrophic problems that can result in the power system from a protection failure, the practice is to use several relays or relay systems operating in parallel. These can be at the same location (primary backup), at the same station (local backup), or at various remote stations (remote backup). All three are used together in many applications. In higher-voltage power systems this concept is extended by providing separate current or voltage, or both measuring devices, separate trip coils on the circuit breakers, and separate tripping battery sources.

The various protective devices must be properly coordinated such that the primary relays assigned to operate at the first sign of trouble in their assigned protective zone operate first. Should they fail, various backup systems must be available and able to operate to clear the trouble. An adequate, high-protection redundancy capability is very important. Additional redundancy, however, does have a negative impact on security. As more systems are added to enhance dependability, an increased probability of incorrect operations results. Good judgment must be utilized when applying protective relaying in order to optimize the balance between dependability and security. The optimal balance will vary, depending on the characteristics and objectives of each specific application.

1.2 TYPICAL PROTECTIVE RELAYS AND RELAY SYSTEMS

Logic representation of an electric relay is shown in Figure 1.2. The components can be electromechanical, electronic, or both. The logic functions are general in nature, so that in any particular unit they may be combined or, on occasion, not required.

Specific designs and features vary widely with application requirements, different manufacturers, and the time period of the particular design. Originally, all protective relays were of the electromechanical type. Electromechanical type relays are still in widespread use and continue to be manufactured

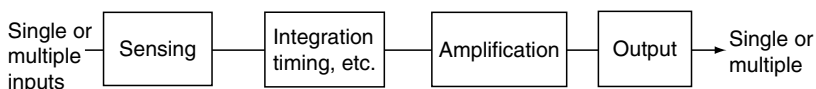

FIGURE 1.2 Logic representation of an electric relay.

and applied. Analog type electronic relays using discrete electronic components were introduced in the 1970s. In recent years, microprocessor-based electronic relays have been developed and are being applied at an increasing rate. Microprocessor-based relays are sometimes referred to as numerical type relays since the analog inputs are converted to digital numbers that are then processed within the relay. Even with this trend toward the utilization of microprocessor-based relays, however, it may be a long time before electromechanical devices are completely replaced.

With electronic relays, the protection principles and fundamentals are essentially unchanged as are the issues regarding protection reliability. Microprocessor type relays do provide many benefits such as higher accuracy, reduced space, lower equipment and installation costs, wider application and setting capabilities, plus various other desirable supplemental features. These include control logic, remote and peer-to-peer communications, data acquisition, event recording, fault location, remote setting, and self monitoring and checking. The specifics of these features will vary between different types of relays and relay manufacturers. Microprocessor-based relays will be discussed in greater detail in [Chapter 15](#).

Various types of protective relays and relay assemblies are illustrated in [Figure 1.3](#) through [Figure 1.6](#). Many modern microprocessor relays utilize a liquid crystal display (LCD) on the front panel. Such displays typically show setting, metering, event, and relay self-test status information. Relay settings can also be changed through the LCD interface without the need for a data terminal. Target information is typically displayed on microprocessor relays with the use of LEDs that identify the protective functions that had operated to initiate tripping along with other information such as the type of fault that had been detected (i.e., A-phase-to-ground), recloser status, etc. Terminal blocks are normally provided on the back of the relay for connecting the various inputs that are required and outputs that are provided by the relay. Communication ports are provided for transmitting digital data.

The fundamental characteristics of relay designs necessary to understand the applications are outlined in [Chapter 6](#) and are augmented as required in subsequent chapters.

1.3 TYPICAL POWER CIRCUIT BREAKERS

Protective relays provide the “brains” to sense trouble, but as low-energy devices, they are not able to open and isolate the problem area of the power system. Circuit breakers and various types of circuit interrupters, including motor contactors and motor controllers, are used for this and provide the “muscle” for fault isolation. Thus, protective relays and circuit breaker-interrupting devices work together; both are necessary for the prompt

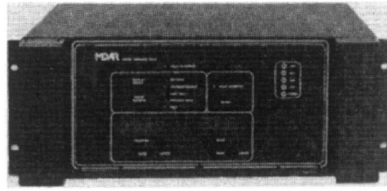

(a)

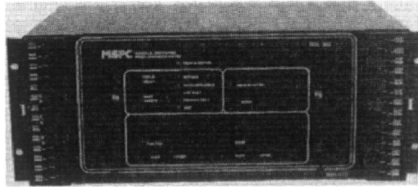

(b)

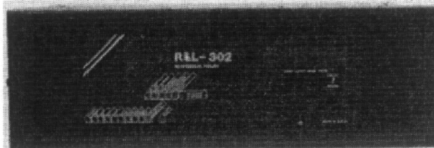

(c)

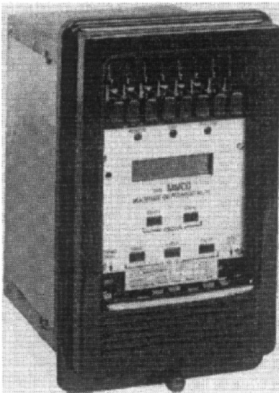

(d)

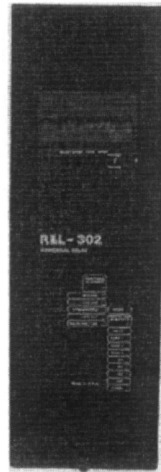

(e)

FIGURE 1.3 Typical solid-state microprocessor relays for power system protection: (a–c) Rack-type mounting: (a) three-phase and ground distance, (b) segregated-phase comparison system, (c) phase and ground distance with pilot capabilities. (d, e) “Flexitest”-type cases for panel mounting: (d) three-phase and ground overcurrent, (e) same as (c). (Courtesy of ABB Power T&D Company, Coral Springs, FL.)

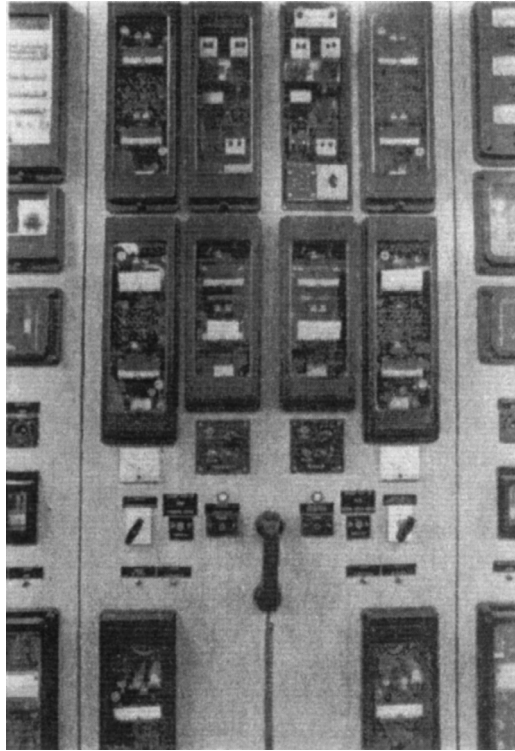

FIGURE 1.4 Typical relay protection for backup of two 500 kV transmission lines using electromechanical protective relays. (Courtesy of Georgia Power Company.)

isolation of a trouble area or damaged equipment. A protective relay without a circuit breaker has no basic value except possibly for alarm. Similarly, a circuit breaker without relays has minimum value, that being for manually energizing or de-energizing a circuit or equipment.

Typical circuit breakers used to isolate a faulted or damaged area are shown in [Figure 1.7](#) and [Figure 1.8](#). Figure 1.7 shows a long row of three-phase 115 kV oil circuit breakers with pneumatic controls in an outdoor substation. These are known as dead-tank breakers; the tank or breaker housing is at ground potential. Toroidal wound-bushing current transformers (CTs) are mounted in the pods just under the fluted porcelain insulators at the top of the tank. This general type is in wide use in many different designs and variations. The media employed for circuit interruption include air, air blast, compressed air gas, and vacuum in addition to oil.

Figure 1.8 shows a 500 kV live-tank circuit breaker. Here the interrupting mechanisms and housing are at the high-voltage level and insulated from

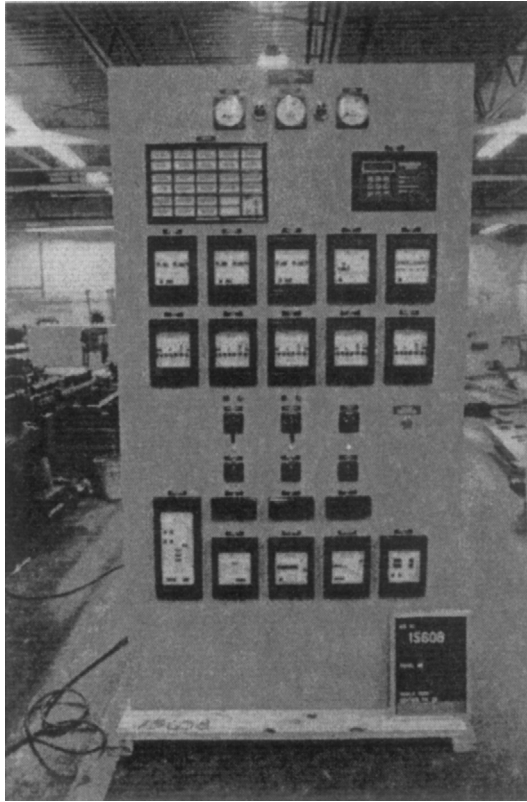

FIGURE 1.5 Typical relay panel for the protection of a cogenerator intertie, using solid-state relays. (Courtesy of Harlo Corporation, Control Panel Division, and Basler Electric.)

ground through the porcelain columns. The CTs are mounted on separate porcelain columns, as shown at the left of each phase breaker.

Dead-tank breaker, such as those illustrated in [Figure 1.7](#), usually have a single trip coil that initiates simultaneous opening of all three-phase breaker poles. The live-tank types generally have a trip coil and mechanism for operating each pole or phase independently. This is evident in [Figure 1.8](#). For these types the relays must energize all three trip coils to open the three-phase power circuit. It is possible to connect the three trip coils in parallel or in series for tripping all three poles. Three trip coils in series are preferred. This arrangement permits easier monitoring of circuit continuity and requires less trip current.

In the United States, the practice for many years has been to open all three phase for all types of faults, even though one or two of the phases may not be

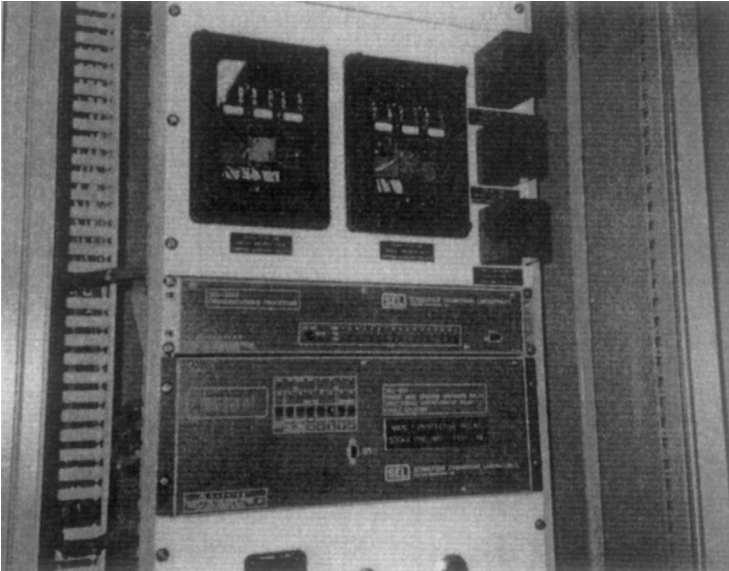

FIGURE 1.6 Typical microprocessor distance relays for single-pole tripping at 500 kV. (Courtesy of Schweitzer Engineering Laboratories, Inc., Pullman, WA.)

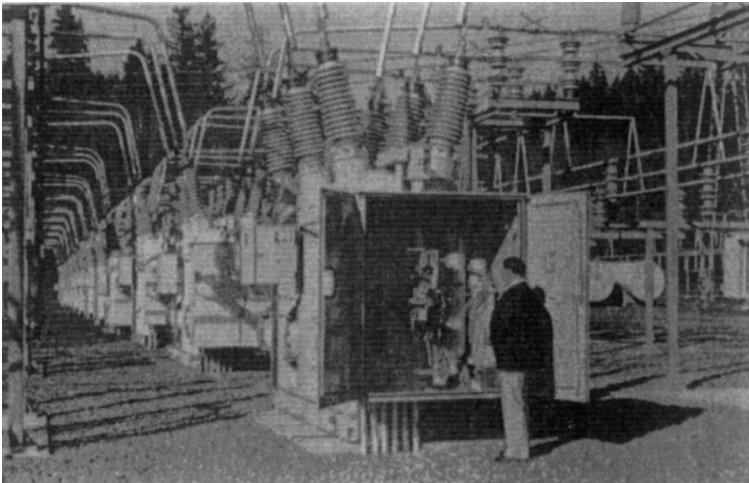

FIGURE 1.7 Row of typical three-phase 115 kV oil circuit breakers. The pneumatic operating mechanism is visible within the open cabinet. (Courtesy of Puget Sound Power and Light Company.)

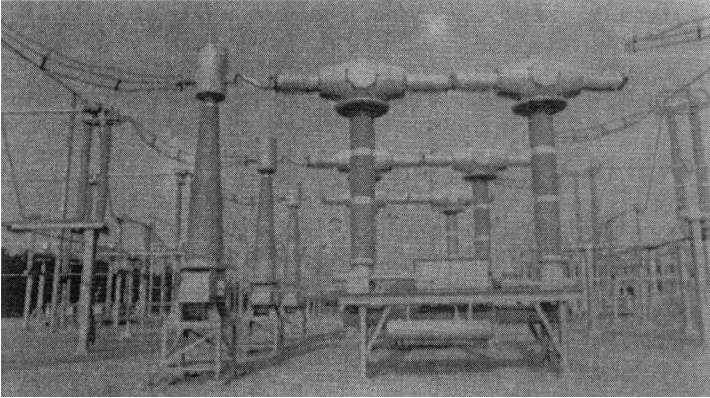

FIGURE 1.8 Typical 500 kV live-tank circuit breaker. Two interrupting mechanisms, operated in series, are mounted on insulating columns, with the associated current transformer on its column at the left. These are single-phase units; three are shown for the three-phase system. (Courtesy of Georgia Power Company.)

involved in the fault. Connecting the three independent trip coils in series for this purpose is known as independent pole tripping.

Any failure of the opening mechanism in single-trip-coil breakers would require the backup protection to isolate the trouble area by opening all other breakers feeding the fault. With independent pole tripping, there is a low probability that all three poles would fail to open by protective relay action; one hopes that at least one or two of the poles would open correctly. Should the fault be three phase, which is the most severe fault for a power system, the opening of at least one or two poles reduces this type of fault to one less severe from a system stability standpoint, either double phase or single phase.

Because most transmission-line faults are transient single-line-to-ground type, opening only the faulted phase would clear it. With a transient fault, such as that resulting from lightning-induced overvoltage, immediate reclosing of the open, faulted phase would restore three-phase service. Known as single-pole tripping, this tends to reduce the shock on the power system. It is discussed further in [Chapter 13](#) and [Chapter 14](#).

As indicated above, at the lower voltages, the circuit breaker (interrupter) and relays frequently are combined into a single-operating unit. The circuit-breaker switches commonly installed in the service entrance cabinet in modern residential homes and commercial buildings are typical examples. In general, this type of arrangement is used up through 480–600 V. Primarily, the protection is overcurrent, although overvoltage may be included. The low accuracy and difficulties of calibration and testing have resulted in a wider application of solid-state technology in these designs. Because the relay units

and breaker are together physically and the voltage exposure level is low, the problems of extraneous voltages and noise that affect solid-state designs are minimized.

1.4 NOMENCLATURE AND DEVICE NUMBERS

The nomenclature and abbreviations used generally follow common practice in the United States. The functions of various relays and equipment are identified by the ANSI/IEEE standardized device function numbers (IEEE C 37.2). A brief review is in order.

The phase of the three-phase system are designated as *A, B, C* or *a, b, c*, rather than 1, 2, 3 (also used in the United States), or *r, s, t* (used in Europe). Also, 1, 2, 3 is avoided because 1 (also designates positive sequence, and 2, negative sequence. Letters avoid possible confusion. Capital letters are used on one side of wye–delta transformer banks, with lower case letters on the other side. Although normally not followed in practice, this emphasizes that there is a phase shift and voltage difference across the transformer bank.

Device numbers with suffix letter(s) provide convenient identification of the basic functions of electrical equipment, such as circuit breakers, relays, switches, and so on. When several units of the same type of device are used in a circuit or system, a number preceding the device number is used to differentiate between them. Letters following the device number provide additional information on the application, use, or actuating quantities. Unfortunately, the same letter may be used with quite a different connotation or meaning. Normally, this will be clear from the use.

Letters and abbreviations frequently used include the following:

A	Alarm
ac or AC	Alternating current
B	Bus, battery, blower
BP	Bypass
BT	Bus tie
C	Current, close, control, capacitor, compensator, case
CC	Closing coil, coupling capacitor, carrier current
CS	Control switch, contactor switch
CT	Current transformer
CCVT	Coupling capacitor voltage device
D	Down, direct, discharge
dc or DC	Direct current
E	Exciter, excitation
F	Field, feeder, fan
G*	Ground, generator
GND, Gnd	Ground

H	Heater, housing
L	Line, lower, level, liquid
M	Motor, metering
MOC	Mechanism-operated contact
MoD	Metal oxide protective device
MOS	Motor-operated switch
N*	Neutral, network
NC	Normally closed
NO	Normally open
O	Open
P	Power, pressure
PB	Pushbutton
PF	Power factor
R	Raise, reactor
S	Speed, secondary, synchronizing
T	Transformer, trip
TC	Trip coil
U	Up, unit
V	Voltage, vacuum
VAR	Reactive power
VT	Voltage transformer
W	Watts, water
X, Y, Z	Auxiliary relays

**N* and *G* (or *n* and *g*) are used in circuits involving ground. A convention that is common but not standardized is the use of *G* when a relay is connected to a CT in the grounded neutral circuit, and *N* when connected in the neutral of three wye-connected CTs. Similar usage is applied to voltage.

Device numbers that are frequently used are listed below. A complete list and definitions are given in Standard IEEE C 37.2.

1. Master element: normally used for hand-operated devices. A common use is the spring-return-to-center control switch for circuit breakers, where the switch contacts are 101T (trip), 101c (close), and 101SC (closed when turned to close and remains closed when released; opened when turned to trip and remains open when released). When several breakers are involved, they are identified by 101, 201, 301, and so on.
2. Time-delay starting on closing relay: except device functions 48, 62, and 79
3. Checking or interlocking relay
4. Master contactor
5. Stopping device
6. Starting circuit breaker
7. Rate-of-rise relay

8. Control power-disconnecting device
9. Reversing device
10. Unit sequence switch
11. Multifunction device
12. Overspeed device
13. Synchronous-speed device
14. Underspeed device
15. Speed- or frequency-matching device
16. Shunting or discharge switch
17. Accelerating or decelerating device
18. Starting-to-running transition contactor
19. Electrically operated valve
20. Distance relay
21. Equalizer circuit breaker
22. Temperature control device
23. Volts/hertz relay
24. Synchronizing or synchronism-check device
25. Apparatus thermal device
26. Undervoltage relay
27. Flame detector
28. Isolating contactor
29. Annunciator relay
30. Separate excitation device
31. Directional power relay
32. Position switch
33. Master sequence device
34. Polarity or polarizing voltage device
35. Undercurrent or underpower relay
36. Bearing protective device
37. Mechanical conduction monitor
38. Field relay
39. Field circuit breaker
40. Running circuit breaker
41. Manual transfer or selector device
42. Unit/sequence starting relay
43. Atmospheric condition monitor
44. Reverse-phase or phase-balance relay
45. Phase-sequence voltage relay
46. Incomplete-sequence relay
47. Machine or transformer thermal relay
48. Instantaneous overcurrent
49. ac Time overcurrent relay

50. ac Circuit breaker. Mechanism-operated contacts are:
 - a. 50a, 50aa: open when breaker contacts are open, closed when breaker contacts are closed
 - b. 50b, 50bb: closed when breaker contacts are open, open when breaker contacts are closed. Here, 50aa and 50bb operate just as mechanism motion starts; known as high-speed contacts
51. Exciter or DC generator relay
52. Power factor relay
53. Field application relay
54. Short-circuiting or grounding device
55. Rectification failure relay
56. Overvoltage relay
57. Voltage or current balance relay
58. Time-delay stopping or opening relay
59. Pressure switch
60. Ground detector relay
61. Governor
62. Notching or jogging device
63. AC directional overcurrent relay
64. Blocking relay
65. Permissive control device
66. Rheostat
67. Level switch
68. DC circuit breaker
69. Load-resistor contactor
70. Alarm relay
71. DC overcurrent relay
72. Telemetering device
73. Phase-single measuring or out-of-step protective relay
74. AC-reclosing relay
75. Flow switch
76. Frequency relay
77. DC-reclosing relay
78. Automatic selective control or transfer relay
79. Operating mechanism
80. Carrier or pilot-wire receiver relay
81. Lockout relay
82. Differential protective relay
83. Auxiliary motor or motor generator
84. Line switch
85. Regulating device
86. Voltage directional relay
87. Voltage and power directional relay
88. Field-changing contactor
89. Tripping or trip-free relay

1.5 TYPICAL RELAY AND CIRCUIT BREAKER CONNECTIONS

Protective relays using electrical quantities are connected to the power system through CT or voltage transformer (VT). These input devices or instrument transformers provide insulation from the high-power system voltages and reduce the magnitudes to practical secondary levels for the relays. As an important element of the protection system, these units are discussed in [Chapter 5](#). In circuit schematics and diagrams they are represented as shown in Figure 1.9. This diagram shows a typical “one-line” AC schematic and a DC trip circuit schematic.

The protective relay system is connected to the AC power system through the CTs commonly associated with the circuit breaker and, if necessary, to the VTs. These are shown connected to the station AC bus, but often at the higher voltages the voltage devices are connected to the transmission line. The circuit breaker is designated as device 52 following the ANSI/IEEE device number system (IEEE C 37.2).

In the DC schematic the contacts are always shown in their de-energized position. Thus, when the circuit breaker is closed and in service, its 52a contact is closed. When a system fault operates the protective relay, its output contact closes to energize the circuit breaker trip coil 52T, which functions to open the breaker main contacts and de-energize the connected power circuit.

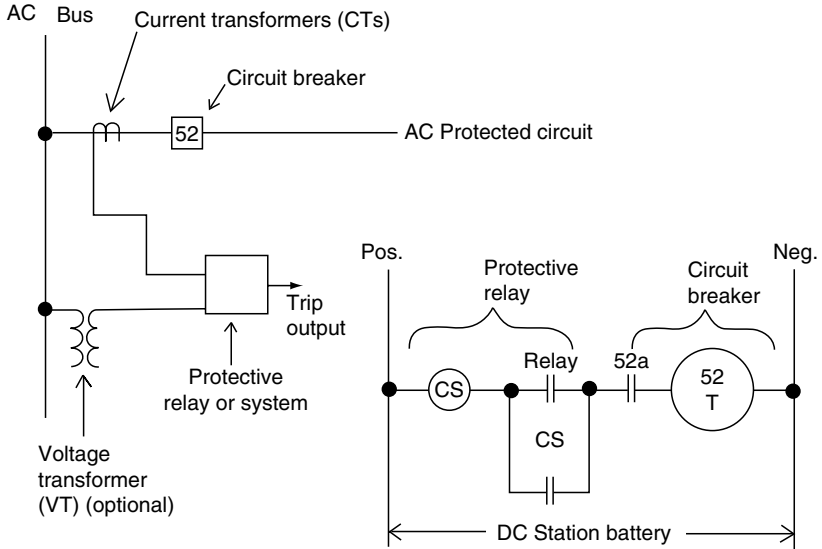

FIGURE 1.9 Typical single-line AC connections of a protective relay with its DC trip circuit. The CS seal in the unit is not required with solid-state units and lower-trip circuit currents with modern circuit breakers.

The electromechanical relay contacts basically are not designed to interrupt the circuit breaker trip coil current, so an auxiliary DC-operated unit designated contactor switch (CS) was used to “seal-in” or bypass the protective relay contacts as shown. When the circuit breaker opens, the 52a switch will open to de-energize the trip coil 52T. The interruption of the fault by the circuit breaker will have opened the protective relay contacts before the 52a contact opens. This CS unit is not required with solid-state relays.

The various power-interrupting devices are operated either by the overcurrent that passes through them during a fault, or by a DC-operated trip coil, such as that shown in [Figure 1.9](#). The first types are designated as series trip, direct acting, direct release, indirect release, and overcurrent release. Usually, these have built-in overcurrent relay units that determine the level of the AC current at and above which their contacts will open. All of these types are used at the lower-voltage level of the power system.

At the higher power system voltages, each station at which circuit breakers are installed has a station battery to supply direct current to the breaker trip coils, the control and protective relay circuits as required, emergency alarms and lighting, and so on. In the United States this is generally 125 V DC; 250 V DC is used in some large power stations, and 48 V DC is often used for electronic and solid-state devices. This DC supply is another vital part of the protection system and requires careful attention and maintenance for high system and protection reliability.

Many protective relays are packaged as individual phase and ground units, so for complete phase- and ground-fault protection, four units are commonly used. Typical three-phase AC connections for a set of relays and their associated CTs and VTs are shown in [Figure 1.10](#). Design of control circuits are discussed in more detail in [Chapter 15](#).

1.6 BASIC OBJECTIVES OF SYSTEM PROTECTION

The fundamental objective of system protection is to provide isolation of a problem area in the power system quickly, so that the shock to the rest of the system is minimized and as much as possible is left intact. Within this context, there are five basic facets of protective relay application.

Before discussing these, it should be noted that the use of the term protection does not indicate or imply that the protection equipment can prevent trouble, such as faults and equipment failures, or electric shocks due to inadvertent human contacts. It cannot anticipate trouble. The protective relays act only after an abnormal or intolerable condition has occurred, with sufficient indication to permit their operation. Thus *protection* does not mean *prevention*, but rather, minimizing the duration of the trouble and limiting the damage, outage time, and related problems that may result otherwise.

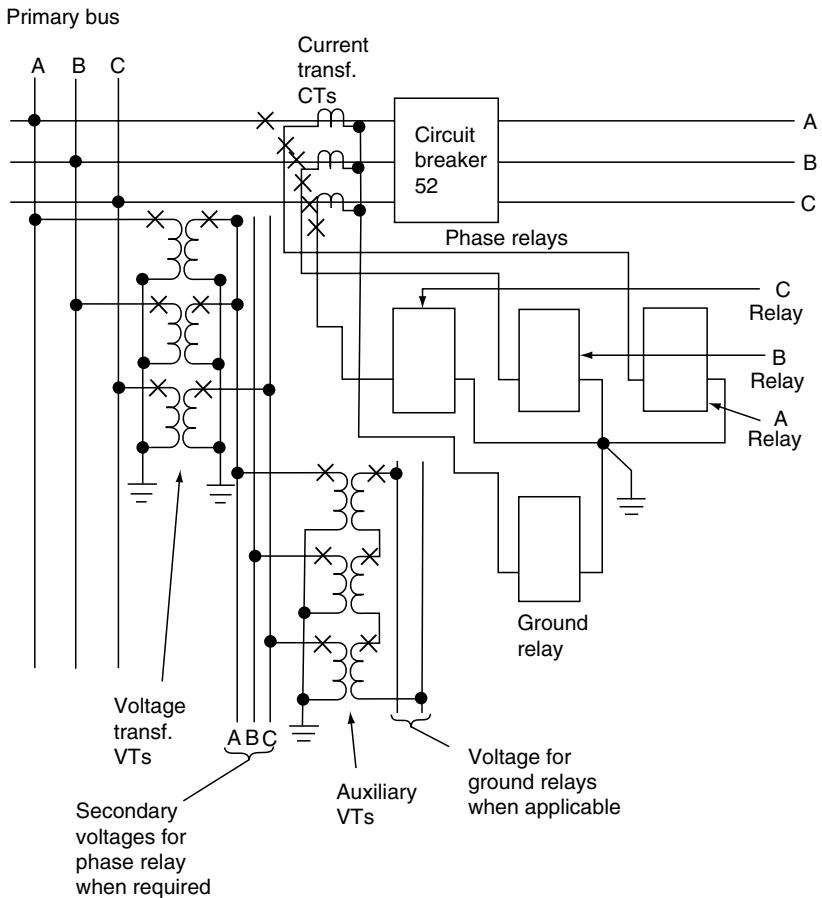

FIGURE 1.10 Typical three-phase AC connections of a set of phase and ground relays for the protection of an AC power system. The relays may be separate, as shown, or combined together in one unit.

The five basic facets are:

1. *Reliability*: assurance that the protection will perform correctly.
2. *Selectivity*: maximum continuity of service with minimum system disconnection.
3. *Speed of operation*: minimum fault duration and consequent equipment damage and system instability.
4. *Simplicity*: minimum protective equipment and associated circuitry to achieve the protection objectives.
5. *Economics*: maximum protection at minimal total cost.

Because these are the underlying foundations of all protection, further discussion is in order.

1.6.1 RELIABILITY

Reliability has two aspects, dependability and security. *Dependability* is defined as “the degree of certainty that a relay or relay system will operate correctly” (IEEE C 37.2). *Security* “relates to the degree of certainty that a relay or relay system will not operate incorrectly” (IEEE C 37.2). In other words, dependability indicates the ability of the protection system to perform correctly when required, whereas security is its ability to avoid unnecessary operation during normal day-after-day operation, and faults and problems outside the designated zone of operation. There is often a very fine line between the tolerable transients that the power system can operate through successfully, and those, such as light faults, that may develop and result in a major problem if not quickly isolated. Thus, the protection must be secure (not operate on tolerable transients), yet dependable (operate on intolerable transients and permanent faults). It is these somewhat conflicting requirements, together with the speculation of what trouble may occur, when, and where, that help make power system protection the most-interesting technical science and art.

Dependability is easy to ascertain by testing the protection system to assure that it will operate as intended when the operating thresholds are exceeded. Security is more difficult to ascertain. There can be almost an infinite variety of transients that might upset the protective system, and predetermination of all these possibilities is difficult or impossible.

Manufacturers often use elaborate power system simulations, computers, and sometimes staged fault tests on energized power systems to check both dependability and security. The practical and best answer to both security and dependability is the background experience of the designers, confirmed by field experience. Thus, actual in-service installations provide the best and final laboratory. This should only confirm the reliability, and not be used basically for the development.

As a generality, enhancing security tends to decrease the dependability, and vice versa. As an illustration, the single relay trip contact shown in [Figure 1.9](#) represents high dependability, but it has the potential of being accidentally closed by unanticipated transients or human error resulting in an undesired operation. To minimize this potential problem, a second relay, such as a fault detector, can be used with its operating contact in series in the DC trip circuit. Now both contacts must close to trip the circuit breaker, which should occur for intolerable conditions or faults. This has increased security, for it is less likely that extraneous transients or problems would cause both relays to operate simultaneously. However, the dependability has been decreased, for it now requires two relays to operate correctly. This arrangement is used, because the dependability is still quite high, together with improved security.

Security is thus very important (as is dependability), as relays are connected for their lifetime to the power system as “silent sentinels,” “waiting” for intolerable conditions and experiencing all the transients and external faults not in their operating zone. The hope always is that there will be no faults or intolerable conditions; hence, no occasion for the relays to operate. Fortunately, there are relatively few faults, on average, in a power system. It is estimated that, in general, the cumulative operating time (the times the relay is sensing and operating for an internal fault) during a relay’s lifetime averages in the order of seconds to a few minutes, depending on the speed of the particular relay type. This contrasts dramatically with a life of over 30 years for many electromechanical relays. Therefore, relays basically do not wear out from operations—indeed, more wear will occur from maintenance testing and similar use.

Similar experience occurs with electronic relays, except that because of the still rapidly changing technology, the lifetime of many of these relays will probably be much shorter.

In general, experiences in power systems, both large and small, utilities and industrial, indicate that their protective relay systems have greater than 99% reliability—a commendable tribute to the industry.

1.6.2 SELECTIVITY

Relays have an assigned area known as the primary protection zone, but they may properly operate in response to conditions outside this zone. In these instances, they provide backup protection for the area outside their primary zone. This is designated as the backup or overreached zone.

Selectivity (also known as relay coordination) is the process of applying and setting the protective relays that overreach other relays such that they operate as fast as possible within their primary zone, but have delayed operation in their backup zone. This is necessary to permit the primary relays assigned to this backup or overreached area time to operate. Otherwise, both sets of relays may operate for faults in this overreached area; the assigned primary relays for the area and the backup relays. Operation of the backup protection is incorrect and undesirable unless the primary protection of that area fails to clear the fault. Consequently, selectivity or relay coordination is important to assure maximum service continuity with minimum system disconnection. This process is discussed in more detail in later chapters.

1.6.3 SPEED

Obviously, it is desirable that the protection isolates a trouble zone as rapidly as possible. In some applications this is not difficult, but in others, particularly where selectivity is involved, faster operation can be accomplished by more complex and a higher-cost protection. Zero-time or very high speed

protection, although inherently desirable, may result in an increased number of undesired operations. As a broad generality, the faster the operation, the higher the probability of incorrect operation. Time, generally of a very small amount, remains as one of the best means of distinguishing between tolerable and intolerable transients.

A high-speed relay is one that operates in less than 50 msec (three cycles on a 60 Hz basis) (IEEE 100). The term *instantaneous* is defined to indicate that no (time) delay is purposely introduced in the action of the device (IEEE 100). In practice, the terms *instantaneous* and *high-speed* are used interchangeably to describe protective relays that operate in 50 msec or less.

Modern high-speed circuit breakers operate in the range of 17–50 msec (one to three cycles at 60 Hz); others operate at less than 83 msec (five cycles at 60 Hz). Thus, the total clearing time (relays plus breaker) typically ranges from approximately 35–130 msec (two to eight cycles at 60 Hz).

In the lower-voltage systems, in which time-coordination is required between protective relays, relay-operating times generally will be slower; typically on the order of 0.2–1.5 sec for the primary zone. Primary-zone relay time longer than 1.5–2.0 sec are unusual for faults in this zone, but they are possible and do exist. Thus, speed is important, but it is not always absolutely required, nor is it always practical to obtain high speed without additional cost and complexity, which may not be justified.

Relay speed is especially important when the protected facility exists in a stability sensitive area of the power system network. Faster fault clearing reduces the amount that generators can accelerate during the fault and, therefore, improves stability margins. Early designs of microprocessor type relays were more or less slower than electromechanical or solid-state analog designs. Modern microprocessor relay designs, however, incorporate processors and algorithms that provide operating speeds that are in the same range as that of other types of relays.

1.6.4 SIMPLICITY

A protective relay system should be kept as simple and straightforward as possible while still accomplishing its intended goals. Each added unit or component, which may offer enhancement of the protection, but is not necessarily basic to the protection requirements, should be considered very carefully. Each addition provides a potential source of trouble and added maintenance. As has been emphasized, incorrect operation or unavailability of the protection can result in catastrophic problems in a power system. Problems in the protective system can greatly impinge on the system—in general, probably more than any other power system component.

The increasing use of solid-state and digital technologies in protective relaying provides many convenient possibilities for increased sophistication. Some will enhance the protection; others add components that are desirable to

have. All adjuncts should be evaluated carefully to assure that they really, and significantly, contribute to improve the system protection.

1.6.5 ECONOMICS

It is fundamental to obtain the maximum protection for the minimum cost, and cost is always a major factor. The lowest-priced, initial-cost-protective system may not be the most reliable one; furthermore, it may involve greater difficulties in installation and operation, as well as higher maintenance costs. Protection costs are considered high when considered alone, but they should be evaluated in the light of the higher cost of the equipment they are protecting, and the cost of an outage or loss of the protected equipment through improper protection. Saving to reduce the first costs can result in spending many more times of this saving to repair or replace equipment damaged or lost because of inadequate or improper protection.

1.6.6 GENERAL SUMMARY

It would indeed be utopian if all five basic objectives could be achieved to their maximum level. Real-life practical considerations require common sense and compromise. Thus, the protection engineer must maximize these as a group for the protection problem at hand and for the requirements of the system. This is an exciting challenge that will produce many different approaches and answers.

1.7 FACTORS AFFECTING THE PROTECTION SYSTEM

There are four major factors that influence protective relaying:

1. Economics
2. “Personality” of the relay engineer and the characteristics of the power system
3. Location and availability of disconnecting and isolating devices [circuit breakers, switches, and input devices (CTs and VTs)]
4. Available fault indicators (fault studies and such).

These are discussed in more detail in the following sections.

1.7.1 ECONOMICS

Economics has been discussed in Section 1.6.5 and is always important. Fortunately, faults and troubles are relatively infrequent, so it is easy to decide not to spend money on protection because there have not been any problems. Certainly, the protection engineer hopes that the protection will never be

called on to operate, but when trouble does occur, protection is vital for the life of the system. A single fault during which the protection promptly and correctly isolates the trouble zone, thereby minimizing the outage time and reducing equipment damage, can more than pay for the protection required.

1.7.2 PERSONALITY FACTOR

What, when, and where an intolerable condition will occur in the power system is unpredictable. The number of possibilities that exist is infinite. Consequently, the engineer must design the protective system for the most probable events, based on past experiences, anticipated possibilities that seem most likely to occur, and the equipment manufacturer's recommendations, well-seasoned by good practical judgment. This tends to make protection an art as well as a technical science. Because the personalities of protection engineers, as well as that of the power system as reflected by management, operating considerations, and historical development, are different, so is the protection that results. Although there is much common technology, protection systems and practices are far from standardized. Accordingly, protection reflects the personality of the engineers and the system, again making the art and practice of system protection most interesting.

1.7.3 LOCATION OF DISCONNECTING AND INPUT DEVICES

Protection can be applied only where there are circuit breakers or similar devices to enable isolation of the trouble area and where CT and VT, when required, are available to provide information about faults and trouble in the power system. Close cooperation between system planners and protection engineers is important to facilitate optimal performance and operation of the power system.

1.7.4 AVAILABLE FAULT INDICATORS

The troubles, faults, and intolerable conditions must provide a distinguishable difference from the normal operating or tolerable conditions. Some signal or change in the quantities—"handle"—is necessary to cause relay operation or detection of the problem. Reiterating, common handles available are current, voltage, impedance, reactance, power, power factor, power or current direction, frequency, temperature, and pressure. Any significant change in these may provide a means to detect abnormal conditions and so be employed for relay operation.

The key to the selection and application of protection is first to determine what measures (handles) exist to distinguish between tolerable and intolerable conditions. From this information, a relay or relay system can be found or designed if necessary to operate on detectable difference(s).

If a significant difference does not exist between the normal and abnormal conditions, protection is limited at best, or it is not possible at all. An example of this exists in distribution systems, where accidents or storms may result in an energized line being near or on the ground. This is totally intolerable, but the fault current can be very small or zero, and all other system parameters such as voltage, power, and frequency, may remain within normal limits. Consequently, in these situations, no handle exists for any type of relay to detect and isolate the intolerable condition.

1.8 CLASSIFICATION OF RELAYS

Relays may be classified in several different ways, such as by function, input, performance characteristics, or operating principles. Classification by function is most common. There are five basic functional types: (1) protective, (2) regulating, (3) reclosing, synchronism check, and synchronizing, (4) monitoring, and (5) auxiliary.

1.8.1 PROTECTIVE RELAYS

Protective relays and associated systems (and fuses) operate on the intolerable power system conditions and are the main thrust of this book. They are applied to all parts of the power system: generators, buses, transformers, transmission lines, distribution lines and feeders, motors and utilization loads, capacitor banks, and reactors. For the most part, the relays discussed are separate devices that are connected to the power system through CT and VTs from the highest system voltage (765 kV, at present) down to service levels of 480 V. In general, distribution equipment below 480 V is protected by fuses or protection devices that are integral with the equipment. Such devices are not discussed in depth here.

1.8.2 REGULATING RELAYS

Regulating relays are associated with tap changers on transformers and on voltage regulators of generating equipment to control the voltage levels with varying loads. Regulating relays are used during normal system operation and do not respond to system faults unless the faults are left on the system far too long. This is not normal. This book does not discuss this type of relay.

1.8.3 RECLOSING, SYNCHRONISM CHECK, AND SYNCHRONIZING RELAYS

Reclosing, synchronism check, and synchronizing relays were formerly classed as programming, but because this term is now widely used in a different context as related to computers, a name change has been made. Relays of this type are used in energizing or restoring lines to services after an outage, and in interconnecting preenergized parts of systems.

1.8.4 MONITORING RELAYS

Monitoring relays are used to verify conditions in the power system or in the protective system. Examples in power systems are fault detectors, voltage check, or directional-sensing units that confirm power system conditions but do not directly sense the fault or trouble. In a protection system, they are used to monitor the continuity of circuits, such as pilot wires and trip circuits. In general, alarm units serve as monitoring functions.

1.8.5 AUXILIARY RELAYS

Auxiliary units are used throughout a protective system for a variety of purposes. Generally, there are two categories: contact multiplication and circuit isolation. In relaying and control systems there are frequent requirements for (1) more outputs for multiple tripping, alarms, and operating other equipment, such as recording and data acquisition, lockout, and so on, (2) contacts that will handle higher currents or voltages in the secondary systems, and (3) electrical and magnetic isolation of several secondary circuits.

The seal-in (CS) relay of [Figure 1.9](#) is an auxiliary relay application. The trip and closing relays used with circuit breakers are auxiliary relays.

1.8.6 OTHER RELAY CLASSIFICATIONS

Protective relays classified by input are known as current, voltage, power, frequency, and temperature relays. Those classified by operating principle include electromechanical, solid-state, digital, percentage differential, multi-restraint, and product units. Those classified by performance characteristics are known as distance, reactance, directional overcurrent, inverse time, phase, ground, definite, high-speed, slow-speed, phase comparison, overcurrent, undervoltage, overvoltage, etc.

1.9 PROTECTIVE RELAY PERFORMANCE

It is difficult to completely evaluate an individual protective relay's performance, because many relays near the trouble area may begin to operate for any given fault. Good performance occurs only when the primary relays operate to isolate the trouble area. All other alerted relays will return to their normal quiescent mode.

Performance (relay operation) can be categorized as follows:

1. Correct, generally 95%–99%
 - a. As planned
 - b. Not as planned or expected

2. Incorrect, either failure to trip or false tripping
 - a. Not as planned or wanted
 - b. Acceptable for the particular situation
3. No conclusion.

1.9.1 CORRECT OPERATION

Correct operation indicates that (1) at least one of the primary relays operated correctly, (2) none of the backup relays operated to trip for the fault, and (3) the trouble area was properly isolated in the time expected. Over many years and today close to 99% of all relay operations are corrected and wanted (i.e., operation is as planned and programmed). This is a tribute to the relay protection departments, their engineers, technicians, and all associated personnel.

The 1965 Northeast blackout was an excellent example of the “correct, not as planned or expected” category. Of the many, many relays that operated during the event, all (as far as I remember) operated correctly. That is, the system quantities got into the operation zones or levels such that the relays operated correctly, but were generally unwanted. At that time no one had anticipated this most unusual system disturbance.

Recently, a utility engineer reported that a fault was cleared in his system by two incorrect operations. This was certainly not planned or anticipated.

1.9.2 INCORRECT OPERATION

Incorrect operations result from a failure, a malfunction, or an unanticipated or unplanned operation of the protective system. This can cause either incorrect isolation of a no-trouble area, or a failure to isolate a trouble area. The reasons for incorrect operation can be one or a combination of (1) misapplication of relays, (2) incorrect setting, (3) personnel errors, and (4) equipment problems or failures (relays, breakers, CTs, VTs, station battery, wiring, pilot channel, auxiliaries, and so on).

It is practically impossible to anticipate and provide protection for the numerous possible power system problems. With the best of planning and design there will always be a potential situation that may not be “protected,” or an error not detected. Occasionally, these are “covered” by an incorrect operation that can be classified as “acceptable for the particular situation.” Although these are very few, they have saved power systems and minimized embarrassments.

1.9.3 NO CONCLUSION

No conclusion refers to circumstances during which one or more relays have or appear to have operated, such as the circuit breaker tripping, but no cause can be found. No evidence of a power system fault or trouble, nor apparent failure of the equipment, can cause a frustrating situation. This can result in many hours of postmortem investigations. Fortunately, the present

microprocessor relays with data recording and oscillographs can provide direct evidence or clues to the problem, as well as indicating possibilities that could not have occurred. It is suspected that many of these events are the result of personnel involvement that is not reported, or of intermittent troubles that do not become apparent during testing and investigation.

1.10 PRINCIPLES OF RELAY APPLICATION

The power system is divided into protection zones defined by the equipment and the available circuit breakers. Six categories of protection zones are possible in each power system: (1) generators and generator–transformer units, (2) transformers, (3) buses, (4) lines (transmission, subtransmission, and distribution), (5) utilization equipment (motors, static loads, or other), and (6) capacitor or reactor banks (when separately protected).

Most of these zones are illustrated in Figure 1.11. Although the fundamentals of protection are quite similar, each of these six categories has protective relays, specifically designed for primary protection, that are

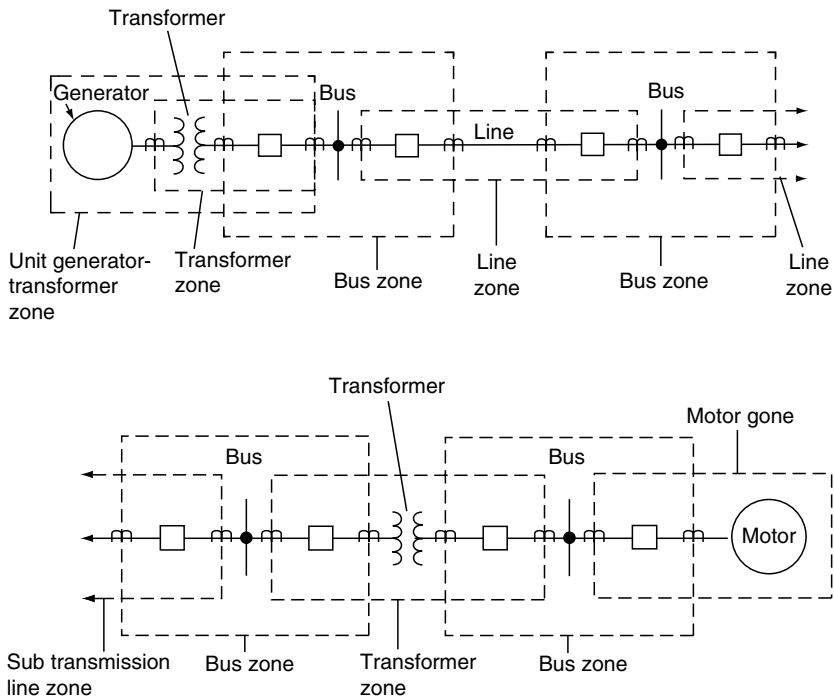

FIGURE 1.11 Typical relay primary protection zones in a power system.

based on the characteristics of the equipment being protected. The protection of each zone normally includes relays that can provide backup for the relays protecting the adjacent equipment.

The protection in each zone should overlap that in the adjacent zone; otherwise, a primary protection void would occur between the protection zones. This overlap is accomplished by the location of the CTs—the key sources of power system information for the relays. This is shown in [Figure 1.11](#) and, more specifically, in [Figure 1.12](#). Faults between the two CTs (see [Figure 1.12](#)) result in both zone X and zone Y relays operating and both tripping the associated circuit breaker.

For case (a): this fault probably involves the circuit breaker itself and so may not be cleared until the remote breakers at either end are opened. For case (b): zone Y relays alone opening the circuit breaker would clear faults between the two CTs from the left fault source. The relays at the remote right source must also be opened for these faults. The operation of the zone X relays is not required, but it cannot be prevented.

Fortunately, the area of exposure is quite small, and the possibility of faults is low. Without this overlap, primary protection for the area between the CTs would not exist, so this overlap is standard practice in all applications.

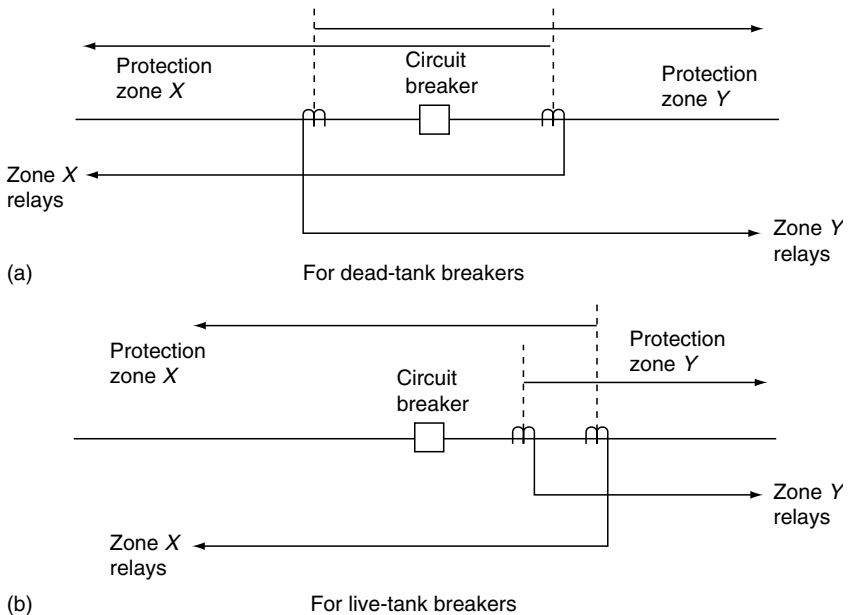

FIGURE 1.12 Overlapping protection zones with their associated current transformers.

1.11 INFORMATION FOR APPLICATION

One of the most difficult aspects of applying is often an accurate statement of the protection requirements or problem. This is valuable as an aid to a practical efficient solution, and is particularly important when assistance is desired from others who might be involved or might assist in the solution, such as consultants, manufacturers, and other engineers. The following checklist of required information has been developed from many years of assisting relay engineers with their problems. It outlines the information needed, some of which is invariably overlooked in the first definition of the problem.

The required information should include the following:

1. Single-line diagram of the system or area involved
2. Impedance and connections of the power equipment, system frequency, voltage, and phase sequence
3. Unless new, existing protection and problems
4. Operating procedures and practices affecting the protection
5. Importance of the protection; pilot, nonpilot, and so on
6. System fault study
7. Maximum load and system swing limits
8. CT and VT locations, connections, and ratios
9. Future expansions expected or anticipated.

More detail on these follows.

1.11.1 SYSTEM CONFIGURATION

A single-line diagram for application considerations or a three-line diagram for complete connections and panel-wiring drawings documenting the area to be studied and of the surrounding system should be available. The location of the circuit breakers, CT and VT, generators, buses, and taps on lines should be shown. The transformer bank connections and system grounding are necessary when considering ground-fault protection. The grounding information is often missing on station drawings.

1.11.2 IMPEDANCE AND CONNECTION OF THE POWER EQUIPMENT, SYSTEM FREQUENCY, SYSTEM VOLTAGE, AND SYSTEM PHASE SEQUENCE

Most of this information is usually included on the single-term diagram, but often omitted are the connections and grounding of the power transformer banks, and the circuit impedance. Phase sequence is necessary when a three-line connection diagram is required.

1.11.3 EXISTING PROTECTION AND PROBLEMS

If it is a new installation this does not apply, but should be indicated. If not new, such information about the existing protection and any problems may assist updating or integration with the changes desired.

1.11.4 OPERATING PROCEDURES AND PRACTICES

Additions or changes should conform to the existing practices, procedures, and desires. When these affect the protection, they should be indicated. Often this can be accomplished by indicating that certain types of equipment or practices are unacceptable.

1.11.5 IMPORTANCE OF THE SYSTEM EQUIPMENT BEING PROTECTED

This is often apparent by the system voltage level and size. For example, high-voltage transmission lines are usually protected by high-speed pilot protection, and low-voltage systems by time-overcurrent protection. However, this should be clarified according to the desires of the protection engineers or the requirements of the system. In general, the more important the equipment that needs protection is to the power system and its ability to maintain service, the more important it becomes to provide full and adequate high-speed protection.

1.11.6 SYSTEM FAULT STUDY

A fault study is important for most protection applications. For phase-fault protection, a three-phase fault study is required, whereas for ground-fault protection a single-line-to-ground fault study is required. The latter should include the zero-sequence voltages and the negative-sequence currents and voltages, which can be useful if directional sensing of ground faults is involved.

On lines, information concerning a fault on the line side at an open breaker (known as a “line-end” fault) is frequently important. The currents recorded should be those that will flow through the relays or fuses, rather than the total fault current.

The fault study should indicate the units (in volts or amperes) at a specified voltage base, or in per unit with the base clearly specified. Experience has shown that quite often the base of the quantities is not shown, or is not clearly indicated.

1.11.7 MAXIMUM LOADS AND SYSTEM SWING LIMITS

The maximum load that will be permitted to pass through the equipment during short-time or emergency operation for which the protection must not operate should be specified. If known, the maximum system swing from which the power system can recover after a transient disturbance is important in some applications and should be specified.

1.11.8 CURRENT AND VOLTAGE TRANSFORMER LOCATIONS, CONNECTIONS, AND RATIOS

This information is often shown on the one-line drawing, but often the data are incomplete or nuclear. Where multiratio devices exist, the specific tap or ratio in use should be specified. The grounding of the VT or voltage devices should be clear.

1.11.9 FUTURE EXPANSION

The system growth or changes that are likely to occur within a reasonable time and are known or planned should be indicated.

Not all of the foregoing items necessarily apply to a specific problem or system requirement, but this checklist should assist in providing a better understanding of the protection problems and requirements. Usually, the fault study, together with related information, will provide information on the measurable quantities (handles) to which the protective relays can respond. When this is not apparent, the first priority for any application is to search for the handles that can be used to distinguish between tolerable and intolerable conditions.

1.12 STRUCTURAL CHANGES WITHIN THE ELECTRIC POWER INDUSTRY

The electric power industry has historically been structured with entities that are vertically integrated monopolies that are regulated by governmental agencies. These industry entities are mainly made up of investor owned utilities and also consist of utilities that are owned by municipals or electric cooperatives. Under such structure, each utility owned all generation, transmission, and distribution facilities within its designated service territory. Each utility likewise owned the protection systems that existed within its territory which included those at generating plants, on the transmission and distribution system, down to the point of interface with customer facilities. The utility was solely responsible for the application, design, construction, settings, testing, and maintenance of all related protection facilities.

In the 1990s, a movement developed to restructure the US electric power industry to one that is more competitive in nature. Various legislations have been passed at both the federal and state levels to force such changes to be implemented. It was felt that competition would lead to greater efficiencies within the industry and would ultimately benefit consumers by providing lower-priced electric energy. This movement is still in an evolutionary state but has initiated significant changes to the industry. Many of the laws that have been passed are state laws, so differences do exist among various areas of the country. The basic result, however, is a power system in which

generation and supply are unregulated. Anyone can own generating facilities with the transmission system opened up to all qualified users. Likewise, anyone can offer to supply energy to customers. Transmission and distribution facilities typically remain regulated and are owned by the utility company. Propositions have been made, however, in which transmission facilities would be combined and owned by a “regional transmission owner” in a given area. Traditional utilities can still own generation facilities and can also offer to be a supplier. However, these functions must be operated as separate subsidiaries with adequate safeguards to prevent competitive advantage. The responsibility of maintaining a competitive wholesale energy market and assuring power system reliability, in many cases, has been delegated to independent system operators.

The final structure of the electric power industry has yet to evolve. Nevertheless, the direction has been set and participants need to adjust to function effectively within the new environment. Concern has been expressed that power system reliability may decline due to a deteriorating effect that competition may have on the cooperative atmosphere that had prevailed in the past. Credibility to this concern is supported by several severe blackouts, power shortages, and slow response to outages that have occurred in areas where competition has been implemented. Politicians need to be alert to this threat and consider any legislation necessary to assure that a level of reliability and customer service comparable to that which has prevailed and expected in this country is maintained.

Structural changes in the power industry does not change the technical and practical aspect that relate to the application of power system protection. Such change, however, does have an impact on the manner in which the protection process is carried out. It presents new challenges, and requires the need for new protection systems to be considered:

1. The impact of economic constraints, which can develop in a competitive atmosphere, may result in pressures to decrease resources available to support the protection function. Economic benefit from application of protection is sometimes difficult to quantify. Protection engineers need to develop skills required to economically justify proposed protection installations. Familiarity with concepts used in the power system planning process should be a priority.
2. The separation of the various entities within the structure of the power industry will require good documentation and a system for exchanging information in order to conduct protection studies and verify protection information.
3. With generators potentially located at a variety of locations throughout the delivery system, additional hazards to the supply system can be created. Such hazards must be identified and appropriate protection systems applied. This subject is discussed further in [Chapter 8](#).

4. Application of “Special Protection Schemes” may be required in order to accommodate a desired generator installation at a specific location. Such schemes are not protective schemes applied typically for fault protection but are applied to guard against undesired system operation conditions when the generator is operating. Special protection schemes are discussed in greater detail in [Chapter 14](#).
5. Uniform protection design standards, application practices, and maintenance and testing requirements need to be documented and provided to all entities. An auditing and enforcement system to assure compliance to such standard is required.

1.13 RELIABILITY AND PROTECTION STANDARDS

With the significant structural changes that have been evolving within the electric power industry, it has been recognized that standards and procedures need to be developed in order to facilitate effective market operations and to ensure reliable power system operations. Reliability standards have existed for planning and operating power systems for many years. Compliance with these standards has been open to interpretation and is voluntary in nature. With separation of ownership within the industry, reliance on such voluntary compliance is not considered practical to assure that reliability aspects of the power system are given the desired priority. It is also considered mandatory that technical requirements relating to the types of equipment being installed along with the manner in which it is connected, operated, and protected be documented so that all participants in the market are treated in a fair and similar manner. Considerable work has transpired in recent times to expand the scope and detail contained in such standards with a greater emphasis on mandatory compliance through the passing of new legislation, expanded oversight, and penalties for violations. Much of this work is being done by groups with oversight or regulatory authority over the industry. This includes reliability councils, state agencies, federal agencies, and regional transmission organizations.

In the protection area, a variety of ANSI/IEEE standards has been developed over the years and continues to be developed as conditions change. These standards cover various aspects of design requirements for protective equipment and the manner in which such equipment needs to be applied to protect specific electrical facilities. Protection requirements related to issues pertaining to power system reliability and safety applicable to power systems within specified jurisdictional areas are being developed as part of the above process being carried out within oversight and regulatory agencies. The main focus of these protection standards relate to facilities associated with bulk power systems since it is the health of the bulk power system that is critical to maintaining continual and safe operation of the nation’s power grid and in preventing large scale disturbances and outages. Since portions of the power grid are built and owned by many separate entities, standards and related

enforcement procedures are critical to the prevention of weak spots within this vast network. Standards for designs at lower voltage levels are often developed by the utilities themselves in order to meet performance requirements mandated by regulatory agencies. Oversight of standards for lower voltage level facilities does exist in areas where multiple ownerships exist. Consequently, the major emphasis of protection standards that are currently being developed to promote reliability and a fair market pertain to protection requirements for bulk power facilities and for the intertie locations at which generation connects to the utility power system.

Generator intertie protection requirements are discussed further in [Chapter 8](#). For bulk power facilities, the reliability standards are typically built around the important objectives of protective systems as described earlier, such as:

1. Preventing or minimizing equipment damage. While equipment damage can be costly to the owner, such outages also present challenges to the operating reliability of the power system.
2. Minimizing the scope and area of an outage following a system fault.
3. Assuring that faults are detected and cleared in time frames such that the power system remains stable.
4. Allowing power system facilities to be loaded to their full normal and emergency ratings.

Operation design of bulk power systems are such that, as a minimum, the system must remain operational upon the sudden, unexpected loss of any single facility on the system. System operators will alter the generation dispatch or the configuration of the system in order to remain within these operational criteria. To align with this “single contingency” concept, protection standards for bulk power facilities typically require that “redundancy” exists within the protection design. Redundancy is required to assure that the failure of any single protection component, such as an instrument transformer, relay, breaker, control circuit, or communication channel will not result in the failure to be able to detect and isolate faults. The major objectives of the protective systems must remain intact for the failure of any device associated with a protective system. This constraint typically requires the use of two independent protection schemes for each protected facility on bulk power systems. This requirement is discussed in subsequent chapters as protective schemes for various types of equipment are covered.

BIBLIOGRAPHY

The following provides references for this chapter and general references applicable to all chapters.

The IEEE Power System Relaying committee of the Power Engineering Society has documented a Bibliography of Relay Literature from 1927. In recent years

this is issued as a committee report every 2 years. These are in the *AIEE* and *IEEE Transactions* as follows:

Period Covered	Transactions Reference
1927–1939	Vol. 60, 1941; pp. 1435–1447
1940–1943	Vol. 63, 1944; pp. 705–709
1944–1946	Vol. 67, pt. I, 1948; pp. 24–27
1947–1949	Vol. 70, pt. I 1951; pp. 247–250
1950–1952	Vol. 74, pt. III 1955; pp. 45–48
1953–1954	Vol. 76, pt. III, 1957; pp. 126–129
1955–1956	Vol. 78, pt. III, 1959; pp. 78–81
1957–1958	Vol. 79, pt. III, 1960; pp. 39–42
1959–1960	Vol. 81, pt. III, 1962; pp. 109–112
1961–1964	Vol. PAS-85, No. 10, 1966; pp. 1044–1053
1965–1966	Vol. PAS-88, No. 3, 1969; pp. 244–250
1967–1969	Vol. PAS-90, No. 5, 1971; pp. 1982–1988
1970–1971	Vol. PAS-92, No. 3, 1973; pp. 1132–1140
1972–1973	Vol. PAS-94, No. 6, 1975; pp. 2033–3041
1974–1975	Vol. PAS-97, No. 3, 1978; pp. 789–801
1976–1977	Vol. PAS-99, No. 1, 1980; pp. 99–107
1978–1979	Vol. PAS100, No. 5, 1981; pp. 2407–2415
1980–1981	Vol. PAS102, No. 4, 1983; pp. 1014–1024
1982–1983	Vol. PAS104, No. 5, 1985; pp. 1189–1197
1984–1985	Vol. PWRD-2, 2, 1987; pp. 349–358
1986–1987	Vol. PWRD-4, 3, 1989; pp. 1649–1658
1988–1989	Vol. PWRD-6, 4, 1991; pp. 1409–1422
1990	Vol. PWRD-7, 1, 1992; pp. 173–181
1991	Vol. PWRD-8, 3, 1993; pp. 955–961
1992	Vol. PWRD-10, 1, 1995; pp. 142–152
1993	Vol. PWRD-10, 2, 1995; pp. 684–696
1994–Paper # 95 SM 4366	

ANSI/IEEE Standard 100, IEEE Standard Dictionary of Electrical and Electronics Terms, IEEE Service Center, 445 Hoes Lane, Piscataway, NJ 08854.

ANSI/IEEE Standard C37.2, Standard Electrical Power System Device Function Numbers, IEEE Service Center.

ANSI/IEEE Standard C37.100, Definitions for Power Switchgear, IEEE Service Center.

ANSI/IEEE Standard 260, IEEE Standard Letter Symbols for Units of Measurement, IEEE Service Center.

ANSI/IEEE Standard 280, IEEE Standard Letter Symbols for Quantities Used in Electrical Science and Electrical Engineering, IEEE Service Center.

ANSI/IEEE Standard 945, IEEE Recommended Practice for Preferred Metric Units for Use in Electrical and Electronics Science and Technology, IEEE Service Center.

ANSI/IEEE Standard C37.010, Application Guide for AC High-Voltage Circuit Breakers Rated on a Symmetrical Current Basis, IEEE Service Center.

- ANSI/IEEE Standard C37.90, Relays and Relay Systems Associated with Electric Power Apparatus, IEEE Service Center.
- Beeman, D., *Industrial Power Systems Handbook*, McGraw-Hill, New York, 1955.
- Elmore, W.A., Ed., *Protective Relaying: Theory and Applications*, ABB Power T&D Company, Marcel Dekker, New York, 1994.
- Fink, D.G. and Beaty, H.W., *Standard Handbook for Electrical Engineers*, McGraw-Hill, New York, 1968.
- Horowitz, S.H., *Protective Relaying for Power Systems*, IEEE Press, 1980, IEEE Service Center.
- Horowitz, S.H. and Phadice, A.G., *Power System Relaying*, Research Studies Press, England, Distributed by John Wiley & Sons, 1996.
- IEEE Brown Book, Standard 399, Recommended Practice and Industrial and Commercial Power System Analysis, IEEE Service Center.
- IEEE Buff Book, Standard 242, IEEE Recommended Practice for Protection and Coordination of Industrial and Commercial Power Systems, IEEE Service Center.
- IEEE Red Book, Standard 141, Recommended Practice for Electrical Power Distribution for Industrial Plants, IEEE Service Center.
- IEEE Power System Relaying Committee Report, Review of Recent Practices and Trends in Protective Relaying, IEEE Trans. Power Appar. Syst., PAS 100, No. 8, 1981, 4054–4064.
- IEEE Power System Relaying Committee Report, Effects of Changing Utility Environment on Protective Relays, IEEE Service Center.
- Mason, C.R., *The Art and Science of Protective Relaying*, John Wiley & Sons, New York, 1956.
- Van C. Washington, A.R., *Protective Relays, Their Theory and Practice*, Vol. I, John Wiley & Sons., New York, 1962, Vol. II, Chapman & Hall, London, 1974.
- Westinghouse Electric Corp., *Electrical Transmission and Distribution Reference Book*, 4th ed., East Pittsburgh, PA, 1964.
- Westinghouse Electric Corp., *Electric Utility Engineering Reference Book, Vol. 3: Distribution Systems*, East Pittsburgh, PA, 1965.
- Washington Electric Corp., *Applied Protective Relaying*, Coral Springs, FL, 1982.

2 Fundamental Units: Per Unit and Percent Values

2.1 INTRODUCTION

Power systems operate at voltages for which kilovolt (kV) is the most convenient unit for expressing voltage. Also, these systems transmit large amounts of power, so that kilovolt-ampere (kVA) and megavolt-ampere (MVA) are used to express the total (general or apparent) three-phase power. These quantities, together with kilowatts, kilovars, amperes, ohms, flux, and so on, are usually expressed as a per unit or percent of a reference or base value. The per unit and percent nomenclatures are widely used because they simplify specification and computations, especially when different voltage levels and equipment sizes are involved.

This discussion is for three-phase electric systems that are assumed to be balanced or symmetrical up to a point or area of unbalance. This means that the source voltages are equal in magnitude and are 120° displaced in phase relations, and that the impedances of the three-phase circuits are of equal magnitude and phase angle. With this as a beginning, various shunts and series unbalances can be analyzed, principally by the method of symmetrical components. This method is reviewed in [Chapter 4](#).

2.2 PER UNIT AND PERCENT DEFINITIONS

Percent is 100 times per unit. Both percent and per unit are used as a matter of convenience or of personal choice, and it is important to designate either percent (%) or per unit (pu).

The *per unit value* of any quantity is the ratio of that quantity to its base value; the ratio is expressed as a nondimensional decimal number. Thus, actual quantities, such as voltage (V), current (I), power (P), reactive power (Q), volt-amperes (VA), resistance (R), reactance (X), and impedance (Z), can be expressed in per unit or percent as follows:

$$\text{Quantity in per unit} = \frac{\text{actual quantity}}{\text{base value of quantity}}, \quad (2.1)$$

$$\text{Quantity in percent} = (\text{quantity in per unit}) \times 100, \quad (2.2)$$

where *actual quantity* is the scalar or complex value of a quantity expressed in its proper units, such as volts, amperes, ohms, or watts. *Base value of a quantity* refers to an arbitrary or convenient reference of the same quantity chosen and designated as the base. Thus, per unit and percent are dimensionless ratios that may be either scalar or complex numbers.

As an example, for a chosen base of 115 kV, voltages of 92, 115, and 161 kV become 0.80, 1.00, and 1.40 pu or 80%, 100%, and 140%, respectively.

2.3 ADVANTAGES OF PER UNIT AND PERCENT

Some of the advantages of using per unit or percent are as follows:

1. Its representation results in more meaningful data when the relative magnitudes of all the similar circuit quantities can be compared directly.
2. The per unit equivalent impedance of any transformer is the same when referred to either the primary or the secondary side.
3. The per unit impedance of a transformer in a three-phase system is the same, regardless of the type of winding connections (wye–delta, delta–wye, wye–wye, or delta–delta).
4. The per unit method is independent of voltage changes and phase shifts through transformers; and the base voltages in the windings are proportional to the number of turns in the windings.
5. Manufacturers usually specify the impedance of an equipment in per unit or percent on the base of its nameplate rating of power (kVA or MVA) and voltage (V or kV). Thus, the rated impedance can be used directly if the bases chosen are the same as the nameplate ratings.
6. The per unit impedance values of various ratings of equipment lie in a narrow range, whereas the actual ohmic values may vary widely. Therefore, when actual values are unknown, a good approximate value can be used. Typical values for various types of equipment are available from many sources and reference books. Also, the correctness of a specified unit can be checked, when the typical values are known.
7. There is less chance of confusion between single-phase power and three-phase power, or between line-to-line voltage and line-to-neutral voltage.
8. The per unit method is very useful for simulating the steady-state and transient behavior of power systems on computers.
9. The driving or source voltage usually can be assumed to be 1.0 pu for fault and voltage calculations.
10. With per unit, the product of two quantities expressed in per unit is expressed in per unit itself. However, the product of two quantities

expressed as percent must be divided by 100 to obtain the result in percent. Consequently, it is desirable to use per unit, rather than percent, in computations.

2.4 GENERAL RELATIONS BETWEEN CIRCUIT QUANTITIES

Before continuing the discussion of the per unit method, a review of some general relations between circuit quantities applicable to all three-phase power systems is in order. This will focus on the two basic types of connections, wye and delta, shown in Figure 2.1. For either of these, the following basic equations apply:

$$S_{3\phi} = \sqrt{3}V_{LL}I_L \text{ (VA);} \quad (2.3)$$

$$V_{LL} = \sqrt{3}V_{LN} \angle +30^\circ \text{ (V);} \quad (2.4)$$

$$I_L = \frac{S_{3\phi}}{\sqrt{3}V_{LL}} \text{ (A),} \quad (2.5)$$

where $*S$ is the apparent or complex power in volt-amperes (VA, kVA, MVA), P is the active power in watts (W, kW, MW), and Q is the reactive power in vars (var, kvar, Mvar). Thus $S = P + jQ$.

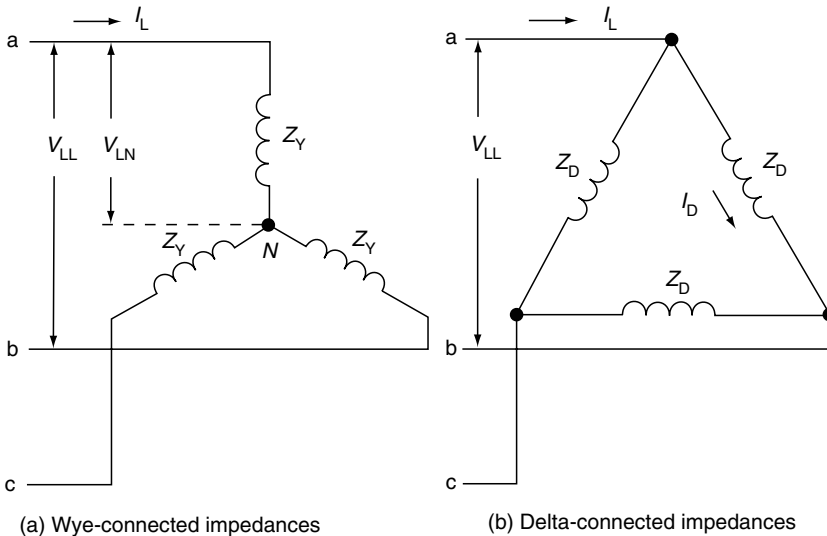

FIGURE 2.1 Impedances in three-phase wye (*left*) and delta (*right*) circuits.

From these three equations the value of the impedances and the delta current can be determined.

1. Wye-connected impedances (see Figure 2.1a):

$$\begin{aligned} Z_Y &= \frac{V_{LN}}{I_L} = \frac{V_{LL} \angle -30^\circ}{\sqrt{3}} \times \frac{\sqrt{3}V_{LL}}{S_{3\phi}} \\ &= \frac{V_{LL}^2 \angle -30^\circ}{S_{3\phi}} (\Omega). \end{aligned} \quad (2.6)$$

2. Delta-connected impedances (see Figure 2.1b):

$$I_D = \frac{I_L \angle +30^\circ - 30^\circ}{\sqrt{3}} \quad (\text{A}) \quad (2.7)$$

$$\begin{aligned} Z_D &= \frac{V_{LL}}{I_D} = \frac{\sqrt{3}V_{LL} \angle -30^\circ}{I_L} = \sqrt{3}V_{LL} \angle -30^\circ \times \frac{\sqrt{3}V_{LL}}{S_{3\phi}} \\ &= \frac{3V_{LL}^2 \angle -30^\circ}{S_{3\phi}} (\Omega) \end{aligned} \quad (2.8)$$

$$I_D = \frac{V_{LL}}{Z_D} = \frac{S_{3\phi} \angle +30^\circ}{3V_{LL}} \quad (\text{A}). \quad (2.9)$$

These equations show that the circuit quantities S , V , I , and Z are related such that the selection of any two of them determines the values of the remaining two quantities. Usually, the wye connection is assumed, so Equation 2.3 through Equation 2.6 are most commonly used for power system calculations. A great deal of confusion can be avoided by clearly remembering that wye connections are assumed and not delta connections, or vice versa. If a delta connection is given, it can be converted into an equivalent wye connection for calculation purposes.

Equation 2.6 and Equation 2.8 assume equal impedances in the wye and delta circuits. From these equations $Z_D = 3Z_Y$ or $Z_Y = Z_D/3$. This equation is useful to convert delta impedances to equivalent wye values.

Alternatively, Equation 2.8 and Equation 2.9 can be used directly if the need arises to express the impedance and current in terms of delta circuit quantities.

2.5 BASE QUANTITIES

In the following chapters, it is more convenient to use the notation kVa or MVA instead of S and kV instead of V . The base quantities are scalar quantities, so that phasor notation is not required for the base equations.

Thus the equations for the base values can be expressed from Equation 2.3, Equation 2.5, and Equation 2.6 with the subscript B to indicate a base quantity, as follows:

$$\text{For base power: } \text{kVA}_B = \sqrt{3} \text{kV}_B I_B \text{ (kVA)}. \quad (2.10)$$

$$\text{For base current: } I_B = \frac{\text{kVA}_B}{\sqrt{3} \text{kV}_B} \text{ (A)}. \quad (2.11)$$

$$\text{For base impedance: } Z_B = \frac{\text{kV}_B^2 \times 1000}{\text{kVA}_B} \text{ (\Omega)}. \quad (2.12)$$

$$\text{and because: } 1000 \times \text{the value of MVA} = \text{kVA}. \quad (2.13)$$

base impedance can also be expressed as

$$Z_B = \frac{\text{kV}_B^2}{\text{MVA}_B} \text{ (\Omega)}. \quad (2.14)$$

In three-phase electric power systems a common practice is to use the standard or nominal system voltage as the voltage base, and a convenient MVA or kVA quantity as the power base. A power base of 100 MVA is widely used. The system voltage commonly specified is the voltage between the three phases (i.e., the line-to-line voltage). This is the voltage used as a base in Equation 2.10 through Equation 2.14. As a shortcut and for convenience, the line-to-line subscript designation (LL) is omitted. With this practice, it is always understood that the voltage is the line-to-line value unless indicated otherwise. The *major exception is in the method of symmetrical components, where line-to-neutral phase voltage is used*. This should always be specified carefully, but there is sometimes a tendency to overlook this step. Similarly, it is always the phase or line-to-neutral current unless otherwise specified.

Power is always understood to be three-phase power unless otherwise indicated. General power, also known as complex or apparent power, is designated by MVA or kVA, as indicated earlier. Three-phase power is designated by MVA or kVA. This power is designated by MW or kW and its reactive power is designated by MVAR or kVAR.

2.6 PER UNIT AND PERCENT IMPEDANCE RELATIONS

Per unit impedance is specified in ohms (Z_Ω) from Equation 2.1 by substituting Equation 2.14:

$$Z_{\text{pu}} = \frac{Z_\Omega}{Z_B} = \frac{\text{MVA}_B Z_\Omega}{\text{kV}_B^2} \text{ or } \frac{\text{kVA}_B Z_\Omega}{1000 \text{ kV}_B^2} \quad (2.15)$$

or, in percent notation,

$$\%Z = \frac{100 \text{ MVA}_B Z_\Omega}{\text{kV}_B^2} \text{ or } \frac{\text{kVA}_B Z_\Omega}{10 \text{ kV}_B^2}. \quad (2.16)$$

If the ohm values are desired from per unit or percent values, the equations are

$$Z_\Omega = \frac{\text{kV}_B^2 Z_{\text{pu}}}{\text{MVA}_B} \text{ or } \frac{1000 \text{ kV}_B^2 Z_{\text{pu}}}{\text{kVA}_B}, \quad (2.17)$$

$$Z_\Omega = \frac{\text{kV}_B^2 (\%Z)_{\text{pu}}}{100 \text{ MVA}_B} \text{ or } \frac{10 \text{ kV}_B^2 (\%Z)}{\text{kVA}_B}. \quad (2.18)$$

The impedance values may be either scalars or phasors. The equations are also applicable for resistance and reactance calculations.

Per unit is recommended for calculations involving division, because it is less likely to result in a decimal-point error. However, the choice of per unit or percent is personal. It is often convenient to use both, but care should be taken.

Careful and overredundant labeling of all answers is strongly recommended. This is valuable in identifying a value or answer, particularly later, when others or you refer to the work. Too often, answers such as 106.8, for example, are indicated without any label. To others, or later when memory is not fresh, questions can arise, such as: “What is this? amperes? volts? per unit what?” Initially, the proper units were obvious, but to others, or later, they may not be. A little extra effort in developing the good habit of labeling leaves no frustrating questions, doubts, or tedious rediscovery later.

Currents in amperes and impedances in ohms should be referred to a specific voltage base or a primary or secondary winding of transformers. Voltages in volts should be clear as to whether they are primary or secondary, high or low, and so on.

When per unit or percent values are specified for impedances, resistances, or reactances, *two bases* must be indicated. These are the MVA (or kVA) and the kV bases using Equation 2.15 through Equation 2.18. Without the two bases, the per unit or percent values are meaningless. For electrical equipment, these two bases are the rate values cited on the equipment nameplate, or on the manufacturer’s drawings, or other data supplied. When several ratings are specified, generally it is correct to assume that the normal-rated values were used to determine the per unit or percent values specified. Fundamentally, the manufacturer should specifically indicate the bases if several ratings exist.

System drawings should clearly indicate the MVA (or kVA) base, with the base voltages indicated for the various voltage levels shown, when all the impedance components have been reduced to one common base value.

Otherwise, the per unit or percent impedances with their two bases must be indicated for every part of equipment or circuit in the drawing.

For per unit or percent voltages, only the voltage base is required. Thus, a 90% voltage on a 138 kV system would be 124.2 kV. For per unit or percent currents, one or two bases are required. If the base current is specified, then that is sufficient. A 0.90 pu current, with a 1000 A base, specifies that the current is 900 A. If the more common MVA (or kVA) and kV bases are given, Equation 2.11, with Equation 2.13, provides the base current that is required. Thus, with 100 MVA 138 kV bases, the base current is

$$I_B = \frac{1000 \times 100}{\sqrt{3} \times 138} = 418.37 \text{ (A) at 138 kV.} \quad (2.19)$$

Thus 418.37 A is 1 pu or 100% current in the 138 kV system.

2.7 PER UNIT AND PERCENT IMPEDANCES OF TRANSFORMER UNITS

As indicated in Section 2.3, a major advantage of the per unit (percent) system is its independence of voltage and phase shifts through transformer banks, where the base voltages on the different terminals of the transformer are proportional to the turns in the corresponding windings.

This can be demonstrated by the following analysis. From basic fundamentals, the impedance on one side of a transformer is reflected through the transformer by the square of the turns ratio, or if the voltages are proportional to the turns, by the square of the voltage ratio. Thus, for one phase of a transformer, as shown in Figure 2.2, the impedance Z_y on the N_y turns winding appears as Z_x on the N_x turns winding side, as

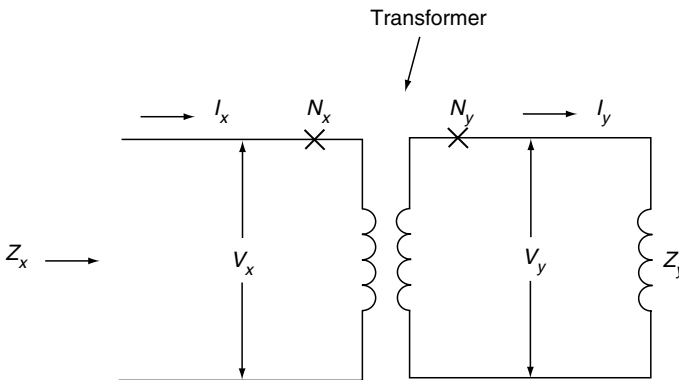

FIGURE 2.2 Impedances through one phase of a three-phase transformer.

$$Z_x = \left(\frac{N_x}{N_y}\right)^2 Z_y = \left(\frac{V_x}{V_y}\right)^2 Z_y (\Omega). \quad (2.20)$$

The impedance bases on the two sides of the transformer are, from [Equation 2.14](#),

$$Z_{xB} = \frac{kV_x^2}{MVA_B} (\Omega), \quad (2.21)$$

where kV_x is the x -side base

$$Z_{yB} = \frac{kV_y^2}{MVA_B} (\Omega), \quad (2.22)$$

where kV_y is the y -side base

Taking the ratio of Z_{xB} and Z_{yB} , yields

$$\frac{Z_{xB}}{Z_{yB}} = \frac{kV_x^2}{kV_y^2} = \left(\frac{N_x}{N_y}\right)^2, \quad (2.23)$$

where the turns are proportional to the voltage.

The per unit impedances are, from [Equation 2.1](#), Equation 2.20, and Equation 2.24,

$$\begin{aligned} Z_{xpu} &= \frac{Z_x(\Omega)}{Z_{xB}} = \left(\frac{N_x}{N_y}\right)^2 \left(\frac{N_y}{N_x}\right)^2 \frac{Z_y(\Omega)}{Z_{yB}} \\ &= \frac{Z_y(\Omega)}{Z_{yB}} = Z_{ypu}. \end{aligned} \quad (2.24)$$

Thus, the per unit impedance is the same on either side of the bank.

2.7.1 TRANSFORMER BANK EXAMPLE

Consider a transformer bank rated 50 MVA with 34.5 kV and 161 kV windings connected to a 34.5 kV and 161 kV power system. The bank reactance is 10%. Now, when looking at the bank from the 34.5 kV system, its reactance is

$$10\% \text{ on a } 50 \text{ MVA, } 34.5 \text{ kV base.} \quad (2.25)$$

and when looking at the bank from the 161 kV system its reactance is

$$10\% \text{ on a } 50 \text{ MVA, } 161 \text{ kV base.} \quad (2.26)$$

This equal impedance in percent or per unit on either side of the bank is independent of the bank connections: wye–delta, delta–wye, wye–wye, or delta–delta.

This indicates that the per unit (percent) impedance values throughout a network can be combined independently of the voltage levels as long as all the impedances are on a common MVA (kVA) base and the transformer windings ratings are compatible with the system voltages. This is very convenient.

The actual transformer impedances in ohms are quite different on the two sides of a transformer, with different voltage levels. This can be illustrated for the example. Applying Equation 2.18, we have

$$jX = \frac{34.5^2 \times 10}{100 \times 50} = 2.38 \, \Omega \text{ at } 34.5 \text{ kV}, \quad (2.27)$$

$$= \frac{161^2 \times 10}{100 \times 50} = 51.84 \, \Omega \text{ at } 161 \text{ kV}. \quad (2.28)$$

This can be checked by Equation 2.20, where, for example, x is the 34.5 kV winding side, and y is the 161 kV winding side. Then,

$$2.38 = \frac{34.5^2}{161^2} \times 51.84 = 2.38. \quad (2.29)$$

2.8 PER UNIT AND PERCENT IMPEDANCES OF GENERATORS

Impedances of generators are provided by the generator manufacturer and are usually given in “per unit” terms on a MVA base that is equal to the nominal MVA rating of the generator. If manufacturer values are not available, generator per unit impedances typically fall within a range such that reasonable estimates can be made for use in studies of a general nature.

The impedance of generators are highly inductive reactive in nature. The resistance of generators is relatively low to an extent that they are usually neglected in fault studies. Generator data sheets typically provide values for several different classifications of generator reactance. It is important to understand the meaning of the various types of reactances provided to determine which one best applies to the study performed.

Reactance values are normally provided for the direct-axis and for the quadrature-axis of the machine. X_d is the symbol used to represent direct-axis reactance values and X_q is the symbol used to represent quadrature-axis values. Direct-axis reactance values are used in fault studies since the direct-axis flux path is the predominant path within which flux flows in the generator during fault conditions, as fault currents typically have a highly lagging phase angle. Generator reactances will also vary over time,

subsequently to when the fault occurs. This is because at the instant when a short circuit occurs, field flux linkages within the generator cannot change instantaneously. The flux necessary to reduce air gap flux to correspond to the lowered generator terminal voltage caused by a fault must therefore, for a time, flow through nonmetallic paths that are high in reluctance and, thus, low in inductance.

Three reactance values are given to represent these changing conditions. Subtransient reactance, (X_d''), is the lowest reactance value and represents the generator reactance that exists at the time the fault initially occurs and lasts for a number of cycles until the effect of damper windings on flux change diminishes. As a representative time frame, X_d'' can be considered to exist for about the first six cycles after a fault occurs. Transient reactance, (X_d'), is somewhat higher than the subtransient value and lasts until the effect of the field windings on flux change diminishes. Transient reactance can be estimated to exist from six cycles to about 30–60 cycles after the fault initially occurs. Synchronous reactance, (X_d), is the highest reactance value for a generator and represents the reactance that exists during steady-state conditions. Synchronous reactance is generally greater than one per unit.

Generator reactance values are also given for saturated and unsaturated conditions within the machine. Saturated values are represented by the subscript “*v*” and unsaturated values by the subscript “*i*.” For protection studies, it is often the highest fault current values that are of greatest significance. Also, during faults, voltages on the power system are usually lower than normal and, consequently, generators will not be in a saturated stage under such conditions. Therefore, it is a usual practice to use the unsaturated subtransient reactance $\{X_{d(i)}''\}$ of generators in fault studies. It is important that protection engineers understand the meaning of the various types of generator reactance values that are given along with the changing character of these values over time, so that the appropriate value is used as warranted by the specific application that is studied. This subject along with appropriate estimates for generator impedances, if specific data is not available, is discussed in greater detail in [Chapter 4](#). After the appropriate value of generator reactance to be used is determined, it needs to be converted to the MVA base of the related study. This conversion can be accomplished using [Equation 2.34](#).

2.9 PER UNIT AND PERCENT IMPEDANCES OF OVERHEAD LINES

Impedance of overhead lines consists of resistance, inductive reactance, and capacitive reactance. All values are usually significant. However, the capacitive reactance of lines is usually ignored in fault studies since it has a minor effect on the resultant fault currents.

Resistance of lines is a function of the conductor material and cross-sectional area. Resistance values for various types of conductors are available

in tables provided by conductor manufacturers. Effective resistance values, which take skin effect into account, is the appropriate value to be used in fault studies.

The inductive reactance of overhead lines is, to a large extent, dependent on the characteristics of the conductor and the physical spacing that exists between the conductors. The greater the distance that exists between the conductors that make up the three-phase circuit, the greater will be the inductive reactance of the circuit. Thus, higher voltage lines with greater conductor spacing, will have a higher inductive reactance (and X/R ratio) than that of lower voltage lines. Estimated impedance values for overhead lines are presented in [Chapter 4](#).

When the ohmic impedance of a line is calculated, its per unit value can be determined by utilizing [Equation 2.15](#). Base kV is selected to correspond to the nominal operating voltage of the associated line. Note that the per unit impedance of a line will vary inversely with the square of its nominal operating voltage.

While the shunt capacitive reactances of lines are typically neglected in short circuit studies, it is not the case with load flow studies. Line charging current can have a significant influence on VAR flows and system voltage levels, particularly at the higher voltage transmission portion of the system.

2.10 CHANGING PER UNIT (PERCENT) QUANTITIES TO DIFFERENT BASES

Normally, the per unit or percent impedances of equipment is specified on the equipment base, which will be generally different from the power system base. Because all impedances in the system must be expressed with the same base for per unit or percent calculations, it is necessary to convert all the values to the common base selected. This conversion can be derived by expressing the same impedance in ohms with two different per unit bases. From [Equation 2.15](#) for a MVA_1, kV_1 base, and a MVA_2, kV_2 base,

$$Z_{1pu} = \frac{MVA_1 Z}{kV_1^2} (\Omega), \quad (2.30)$$

$$Z_{2pu} = \frac{MVA_2 Z}{kV_2^2} (\Omega). \quad (2.31)$$

By finding the ratio of these two equations and solving for one per unit value, the general equation for changing bases is:

$$\frac{Z_{2pu}}{Z_{1pu}} = \frac{MVA_2}{kV_2^2} \times \frac{kV_1^2}{MVA_1}, \quad (2.32)$$

$$Z_{2\text{pu}} = Z_{1\text{pu}} \frac{\text{MVA}_2}{\text{MVA}_1} \times \frac{\text{kV}_1^2}{\text{kV}_2^2}. \quad (2.33)$$

Equation 2.33 is the general equation for changing from one base to another base. In most of the cases the ratio of the number of turns of the transformer is equivalent to the different system voltages, and the equipment-rated voltages are the same as the system voltages, so that the voltage-squared ratio is unity. Thus, Equation 2.33 reduces to

$$Z_{2\text{pu}} = Z_{1\text{pu}} \frac{\text{MVA}_2}{\text{MVA}_1}. \quad (2.34)$$

It is very important to emphasize that the voltage-square factor of Equation 2.33 is used *only* in the same voltage level and when slightly different voltage bases exist. It is *never* used when the base voltages are proportional to the transformer bank turns, such as going from the high to the low side across a bank. In other words, Equation 2.33 has nothing to do with transferring the ohmic impedance value from one side of a transformer to the other side.

Several examples will illustrate the applications of Equation 2.33 and Equation 2.34 in changing per unit and percent impedances from one base to another.

2.10.1 EXAMPLE: BASE CONVERSION WITH EQUATION 2.34

The 50-MVA 34.5:161 kV transformer with 10% reactance is connected to a power system where all the other impedance values are on a 100 MVA 34.5 kV or 161 kV base. To change the base of the transformer, Equation 2.34 is used because the transformer and system base voltages are the same. This is because if the fundamental Equation 2.33 was used,

$$\frac{\text{kV}_1^2}{\text{kV}_2^2} = \left(\frac{34.5}{34.5}\right)^2 \text{ or } \left(\frac{161}{161}\right)^2 = 1.0. \quad (2.35)$$

Thus, the transformer reactance in Equation 2.34 results,

$$jX = 10\% \times \frac{100}{50} = 20\% \text{ or } 0.20 \text{ pu} \quad (2.36)$$

on a 100 MVA 34.5 kV base from the 34.5 kV side, or on a 100 MVA 161 kV base from the 161 kV side.

2.10.2 EXAMPLE: BASE CONVERSION REQUIRING EQUATION 2.33

A generator and transformer, shown in [Figure 2.3](#), are to be combined into a single equivalent reactance on a 100 MVA, 110 kV base. With the

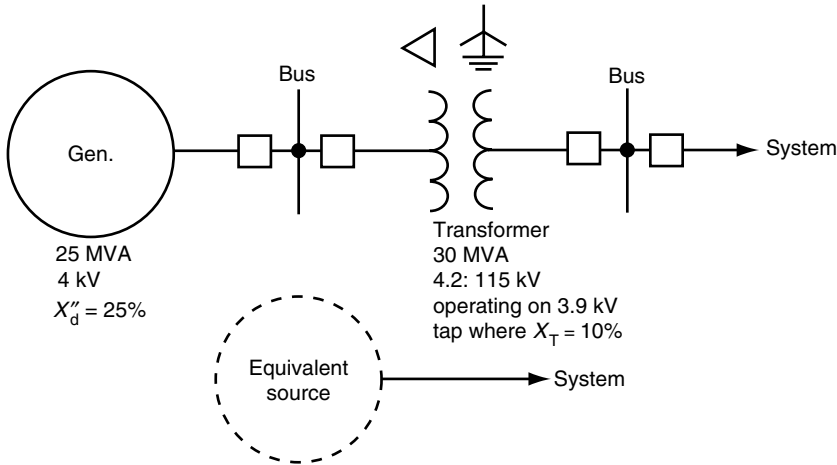

$$X_{eg} = 151.43\% = 1.154 \text{ pu on } 100 \text{ MVA, } 110 \text{ kV Base}$$

FIGURE 2.3 Typical example for combining a generator and a transformer into an equivalent source.

transformer bank operating on its 3.9 kV tap, the low-side base voltage corresponding to the 110 kV high-side base is:

$$\frac{kV_{LV}}{110} = \frac{3.9}{115} \text{ or } kV_{LV} = 3.73 \text{ kV.} \quad (2.37)$$

Because this 3.73 kV base is different from the specified base of the generator subtransient reactance, Equation 2.33 must be used:

$$jX''_d = 25\% \times \frac{100 \times 4^2}{25 \times 3.73^2} = 115\% \text{ or } 1.15 \text{ pu}$$

on 100 MVA 3.73 kV base,
or on 100 MVA 110 kV base. (2.38)

Similarly, the transformer reactance on the new base is

$$jX_T = 10\% \times \frac{100 \times 3.9^2}{30 \times 3.73^2} = 10\% \times \frac{100 \times 115^2}{30 \times 110^2}$$

= 36.43% or 0.364 pu on 100 MVA 3.73 kV base,
or on 100 MVA 110 kV base. (2.39)

Now the generator and transformer reactances can be combined into one equivalent source value by adding:

$$115\% + 36.43\% = 151.43\%$$

or

$$1.15 \text{ pu} + 0.3643 \text{ pu} = 1.514 \text{ pu, both on a 100 MVA 110 kV base. (2.40)}$$

The previous warning bears repeating and emphasizing. Never, *never*, NEVER use Equation 2.33 with voltages on the opposite sides of transformers. Thus, the factors $(115/3.9)^2$ and $(110/3.73)^2$ in Equation 2.3 are *incorrect*.

See the bibliography at the end of Chapter 1 for additional information.

BIBLIOGRAPHY

- Fitzgerald, A.E., Kingsley, C., and Umans, S.D., *Electric Machinery*, McGraw-Hill, New York, 1983.
- Grainger, J.J. and Stevenson, W.D., *Power System Analysis*, McGraw-Hill, New York, 1994.
- Seidman, A.H., Mahrous, H., and Hicks, T.G., *Handbook of Electric Power Calculations*, McGraw-Hill, New York, 1983.
- Weedy, B.M., *Electric Power Systems*, 3rd ed., John Wiley & Sons, New York, 1979.

3 Phasors and Polarity

3.1 INTRODUCTION

Phasors and polarity are two important and useful tools in power system protection. They aid in understanding and analyzing of the connections, operation, and testing of relays and relay systems. In addition, these concepts are essential in understanding power system performance during both normal and abnormal operation. Thus, a sound theoretical and practical knowledge of phasors and polarity is a fundamental and valuable resource.

3.2 PHASORS

The *IEEE Dictionary* (IEEE 100) defines a *phasor* as “a complex number.” Unless otherwise specified, it is used only within the context of steady-state alternating linear systems. It continues: “the absolute value (modulus) of the complex number corresponds to either the peak amplitude or root-mean-square (rms) value of the quantity, and the phase (argument) to the phase angle at zero time. By extension, the term phasor can also be applied to impedance, and related complex quantities that are not time dependent.”

In this book, phasors will be used to document various AC voltages, currents, fluxes, impedances, and power. For many years phasors were referred to as “vectors,” but this use is discouraged to avoid confusion with space vectors. However, the former use lingers on, so occasionally a lapse to vectors may occur.

3.2.1 PHASOR REPRESENTATION

The common pictorial form for representing electrical and magnetic phasor quantities uses the Cartesian coordinates with x (the abscissa) as the axis of real quantities and y (the ordinate) as the axis of imaginary quantities. This is illustrated in [Figure 3.1](#). Thus, a point c on the complex plane x - y can be represented as shown in this figure, and mathematically documented by the several alternative forms given in the following equation:

Phasor form	Rectangular form	Complex	Exponential form	Polar form
-------------	------------------	---------	------------------	------------

$$c = x + jy = |c|(\cos \phi - j \sin \phi) = |c|e^{j\phi} = |c| \angle +\phi. \quad (3.1)$$

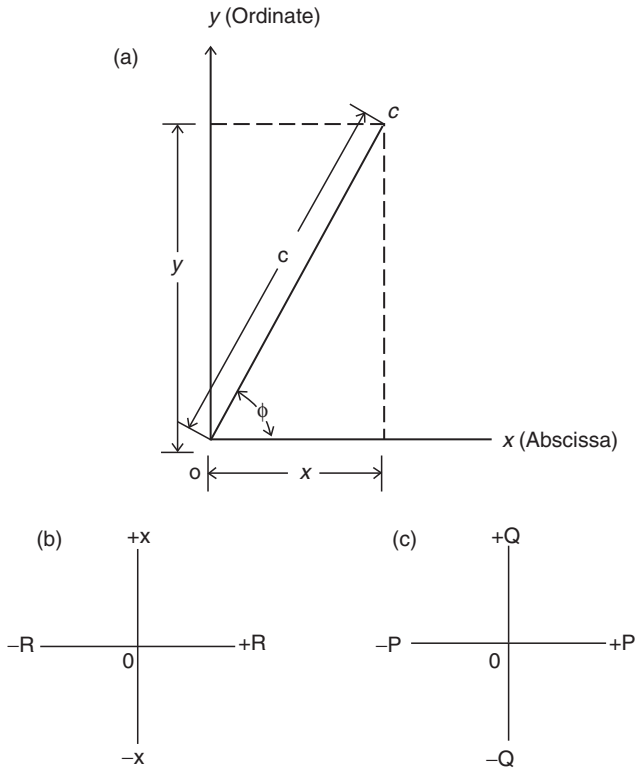

FIGURE 3.1 Reference axes for phasor quantities: (a) Cartesian x - y coordinates. (b) Impedance phasor axes. (c) Power phasor axes.

Sometimes the conjugate form is useful:

$$c^* = x - jy = |c|(\cos \phi - j \sin \phi) = |c|e^{-j\phi} = |c| \angle -\phi, \quad (3.2)$$

where c is the phasor; c^* is its conjugate; x is the real value (alternate: $\text{Re } c$ or c'); y is the imaginary value (alternate: $\text{Im } c$ or c''); $|c|$ is the modulus (magnitude or absolute value); and ϕ is the phase angle (argument or amplitude) (alternate: $\text{arg } c$).

The modulus (magnitude or absolute value) of the phasor is

$$|c| = \sqrt{x^2 + y^2}. \quad (3.3)$$

From Equation 3.1 and Equation 3.3,

$$x = 1/2(c + c^*) \quad (3.4)$$

$$y = \frac{1}{2j}(c - c^*). \quad (3.5)$$

3.2.2 PHASOR DIAGRAMS FOR SINUSOIDAL QUANTITIES

In applying the preceding notation to sinusoidal (AC) voltages, currents, and fluxes, the axes are assumed as fixed, with the phasor quantities rotating at a constant angular velocity. The international standard is that phasors always rotate in the counterclockwise direction. However, as a convenience, on the diagrams the phasor is always shown as fixed for the given condition. The magnitude of the phasor c can be either the maximum peak value or the rms value of the corresponding sinusoidal quantity. In normal practice, it represents the rms maximum value of the positive half-cycle of the sinusoid unless otherwise specifically stated.

Thus, a phasor diagram shows the respective voltages, currents, fluxes, and so on, existing in the electric circuit. It should document only the magnitude and relative phase-angle relations between these various quantities. Therefore, all phasor diagrams require a scale or complete indications of the physical magnitudes of the quantities shown. The phase-angle reference is usually between the quantities shown, so that the zero (or reference angle) may vary with convenience. As an example, in *fault calculations* using reactance X only, it is convenient to use the voltage V reference at $+90^\circ$. Then $I = jV/jX$ and the j value cancels, so the fault current does not involve the j factor. On the other hand, in *load calculations* it is preferable to use the voltage V at 0° or along the x -axis so that the angle of the current I represents its actual lag or lead value.

Other reference axes that are in common use are shown in [Figure 3.1b](#) and [Figure 3.1c](#). For plotting a graph of impedance, resistance, and reactance, the R - X axis of [Figure 3.1b](#) is used. Inductive reactance is $+X$ and capacitive reactance is $-X$.

For plotting power phasors, [Figure 3.1c](#) is used. P is the real power (W, kW, MW) and Q is the reactive power (var, kvar, Mvar). These impedance and power diagrams are discussed in latter chapters. Although represented as phasors, the impedance and power phasors do not rotate at system frequency.

3.2.3 COMBINING PHASORS

The various laws for combining phasors are presented for general reference:

Multiplication. The magnitudes are multiplied and the angles are added:

$$VI = |V||I| \angle \phi_V + \phi_I \quad (3.6)$$

$$VI^* = |V||I| \angle \phi_V - \phi_I \quad (3.7)$$

$$I^* = |I|^2. \quad (3.8)$$

Division. The magnitudes are divided and the angles are subtracted:

$$\frac{V}{I} = \frac{|V|}{|I|} \angle \phi_V - \phi_I. \quad (3.9)$$

Powers.

$$(I)^n = (|I|e^{j\phi})^n = |I|^n e^{jn\phi} \quad (3.10)$$

$$n\sqrt{I} = {}^n\sqrt{|I|e^{jn\phi}}. \quad (3.11)$$

3.2.4 PHASOR DIAGRAMS REQUIRE A CIRCUIT DIAGRAM

The phasor diagram, defined earlier, has an indeterminate or vague meaning unless it is accompanied by a circuit diagram. The circuit diagram identifies the specific circuit involved, with the location and assumed direction for the currents, and the location and assumed polarity for the voltages to be documented in the phasor diagram. The assumed directions and polarities are not critical, because the phasor diagram will confirm if the assumptions are correct, and provide the correct magnitudes and phase relations. These two complementary diagrams (circuit and phasor) are preferably kept separate to avoid confusion and errors in interpretation. This is discussed further in [Section 3.3](#).

3.2.5 NOMENCLATURE FOR CURRENT AND VOLTAGE

Unfortunately, there is no standard nomenclature for current and voltage, so confusion can exist among various authors and publications. The nomenclature used throughout this book has proved to be flexible and practical over many years of use, and it is compatible with the polarities of power system equipment.

3.2.5.1 Current and Flux

In the circuit diagrams, current or flux is shown by either (1) a letter designation, such as I or θ , with an arrow indicator for the assumed direction of flow; or (2) a letter designation with double subscripts, the order of the

subscripts indicating the assumed direction. The direction is thus assumed to be the flow during the positive half-cycle of the sine wave. This convention is illustrated in Figure 3.2a. Thus, in the positive half-cycle, the current in the circuit is assumed to be flowing from left to right, as indicated by the direction of the arrow used with I_s , or denoted by subscripts, as with I_{ab} , I_{bc} , and I_{cd} . The single subscript, such as I_s , is a convenience to designate currents in various parts of a circuit and has no directional indication, so an arrow for the direction must be associated with these. Arrows are not required with I_{ab} , I_{bc} , or I_{cd} , but are often used for added clarity and convenience. It is very important to appreciate that, in these circuit designations, the arrows do not indicate phasors. They are only assumed as directional and locational indicators.

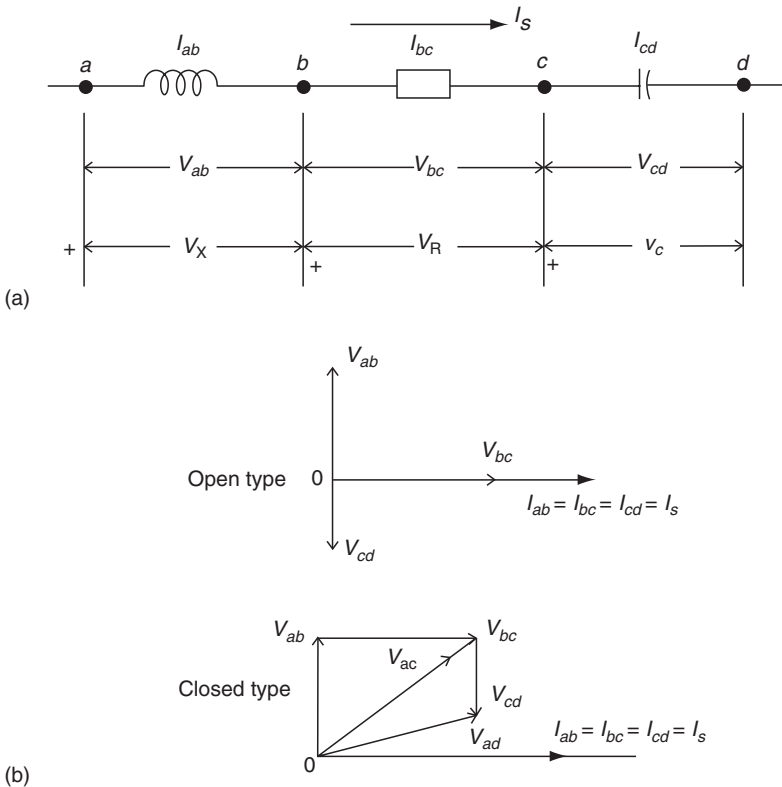

FIGURE 3.2 Phasor diagram for the basic circuit elements: (a) Circuit diagram showing location and assumed directions of current and voltage drops. I and V are locational and directional indicators, not phasors. (b) Phasor diagrams showing current and voltage magnitudes, and phase relations.

3.2.5.2 Voltage

Voltages can be either drops or rises. Much confusion can result by not clearly indicating which is intended or by mixing the two practices in circuit diagrams. This can be avoided by standardizing to one practice. As voltage drops are far more common throughout the power system, all voltages are shown and are always considered to be drops from a higher voltage to a lower voltage during the positive half-cycle. This convention is independent of whether V , E , or U is used for voltage in many countries. In this book, V is used and as indicated, it is always a voltage drop.

The consistent adoption of only drops throughout does not need to cause difficulties. A generator or source voltage becomes a minus drop because current flows from a lower voltage to a higher voltage. This practice does not conflict with the polarity of equipment, such as transformers, and it is consistent with fault calculations using symmetrical components.

Voltages (always drops) are indicated by either (1) a letter designation with double subscripts; or (2) a small plus (+) indicator shown at the point assumed to be at a relatively high potential. Thus, during the positive half-cycle of the sine wave, the voltage drop is indicated by the order of the two subscripts used, or from the “+” indicator to the opposite end of the potential difference. This is illustrated in [Figure 3.2a](#), where both methods are shown. It is preferable to show arrows at both ends of the voltage-drop designations, to avoid possible confusion. Again, it is most important to recognize that both these designations in the circuit diagrams, especially if arrows are used, are only location and direction indicators, not phasors.

It may be helpful to consider current as a “through” quantity and voltage as an “across” quantity. In this sense, in the representative [Figure 3.2a](#), the same current flows through all the elements in series, so that $I_{ab} = I_{bc} = I_{cd} = I_S$. By contrast, voltage V_{ab} applies only across nodes a and b , voltage V_{bc} across nodes b and c , and V_{cd} across nodes c and d .

3.2.6 PHASOR DIAGRAM

With the proper identification and assumed directions established in the circuit diagram, the corresponding phasor diagram can be drawn from the calculated or test data. For the circuit diagram in [Figure 3.2a](#), two types of phasor diagrams are shown in [Figure 3.2b](#). The top diagram is referred to as an *open type*, where all the phasors originate from a common origin. The bottom diagram is referred to as a *closed type*, where the voltage phasors are summed together from left to right for the same series circuit. Both types are useful, but the open type is preferred to avoid the confusion that may occur with the closed type. This is amplified in the following section.

3.3 CIRCUIT AND PHASOR DIAGRAMS FOR A BALANCED THREE-PHASE POWER SYSTEM

A typical section of a three-phase power system is shown in [Figure 3.3a](#). Optional grounding impedances (Z_{Gn}) and (Z_{Hn}) are omitted with solid grounding. This topic is covered in [Chapter 7](#). (R_{sg}) and (R_{ssg}) represent the ground-mat resistance in the station or substation. Ground g or G represents the potential of the true earth, remote ground plane, and so on. The system neutrals n' , n or N , and n'' are not necessarily the same unless a fourth wire is used, as in a four-wire three-phase system. Upper- or lowercase N and n are used interchangeably as convenient for the neutral designation.

The various line currents are assumed to flow through this series section as shown, and the voltages are indicated for a specific point on the line section. These follow the nomenclature that was discussed previously. To simplify the discussion at this point, symmetrical or balanced operation of the three-phase power system is assumed. Therefore, no current can flow in the neutrals of the two transformer banks, so that with this simplification there is no difference of voltage between n' , n or N , n'' , and the ground plane g or G . As a result, $V_{an} = V_{ag}$; $V_{bn} = V_{bg}$; and $V_{cn} = V_{cg}$. Again, this is true only for a balanced or symmetrical system. With this, the respective currents and voltages are equal in magnitude and 120° apart in phase, as shown in the phasor diagram (see [Figure 3.3b](#)), in both open and closed types. The phasors for various unbalanced and fault conditions are discussed in [Chapter 4](#).

The open-type phasor diagram permits easy documentation of all possible currents and voltages, some of which are not convenient in the closed-type phasor diagram. The delta voltage V_{ab} , representing the voltage (drop) from phase a to phase b , is the same as $V_{an} - V_{bn}$. Similarly, $V_{bc} = V_{bn} - V_{cn}$ and $V_{ca} = V_{cn} - V_{an}$.

As indicated, the closed-type phasor diagram can lead to difficulties. As seen in [Figure 3.3b](#), its shape lends itself mentally to an assumption that the three vertices of the triangle represent a , b , and c phases of the power system, and that the origin 0 represents $n = g$. Questions arise with this closed-type phasor diagram about why $V_{an} = V_{ag}$ has its phasor arrow as shown, because the voltage drop is from phase a to neutral; similarly for the other two phases. Also why V_{ab} , V_{bc} , and V_{ca} are pointing as shown, for they are drops from phase a to phase b , phase b to phase c , and phase c to phase a , respectively. It would appear that they should be pointing in the opposite direction.

The phasors shown on this closed phasor diagram (see [Figure 3.3b](#)) are absolutely correct and must not be changed. The difficulty is in combining the circuit diagram with the phasor diagram by the mental association of a , b , and c with the closed triangle. The open type avoids this difficulty. This also emphasizes the desirability of having two separate diagrams: a circuit diagram and a phasor diagram. Each serves particular, but quite different, functions.

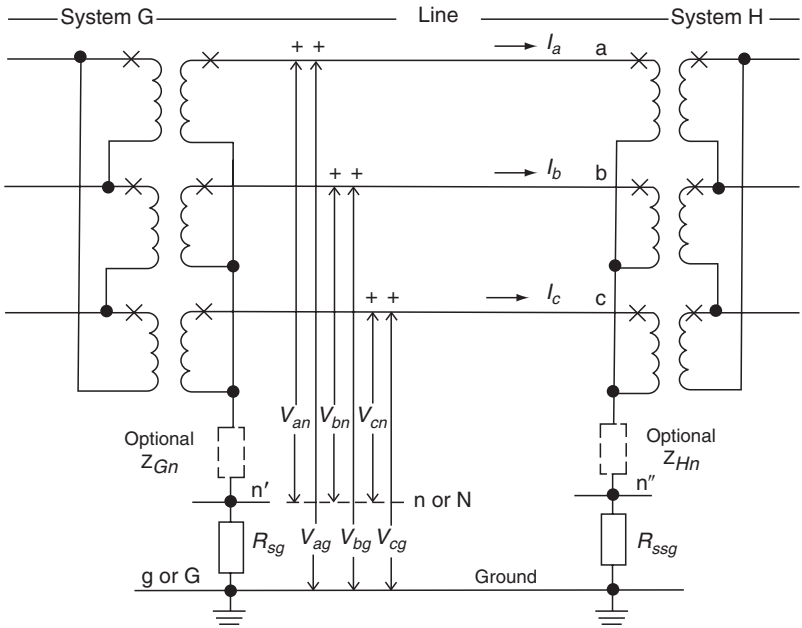

(a)

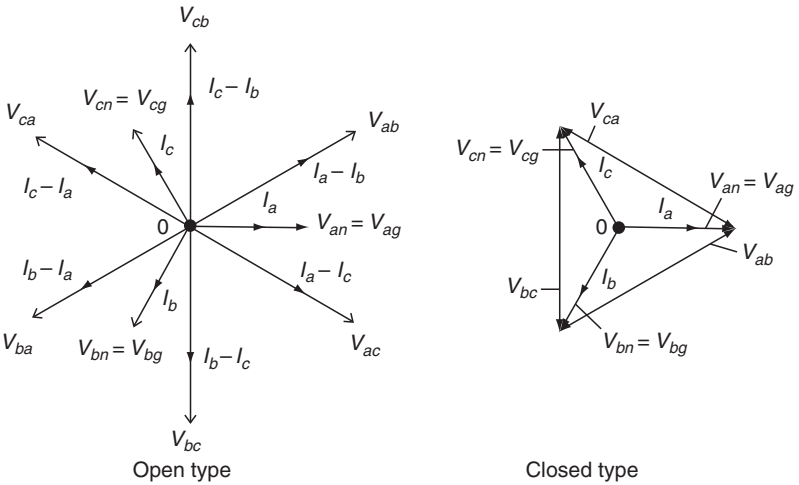

(b)

FIGURE 3.3 Phasor diagram for a typical three-phase circuit operating with balanced or symmetrical quantities. (a) Circuit diagram showing location and assumed directions of current and voltage drops. I and V are locational and directional indicators, not phasors. (b) Phasor diagrams showing current and voltage magnitudes and phase relations.

3.4 PHASOR AND PHASE ROTATION

Phasor and phase rotation are two entirely different terms, although they almost look alike. The AC phasors always rotate counterclockwise at the system frequency. The fixed diagrams, plotted such as in [Figure 3.3b](#), represent what would be seen if a stroboscopic light of system frequency were imposed on the system phasors. The phasors would appear fixed in space, as plotted.

In contrast, phase rotation or phase sequence refers to the order in which the phasors occur as they rotate counterclockwise. The standard sequence today is: a, b, c ; A, B, C ; 1, 2, 3; or in some areas r, s, t . In [Figure 3.3b](#), the sequence is a, b, c , as indicated. The IEEE dictionary (IEEE 100) defines only phase sequence; hence, this is preferred. However, phase rotation has been used over many years and is still in practice.

Not all power systems operate with phase sequence a, b, c , or its equivalent. There are several large electric utilities in the United States that operate with a, c, b phase sequence. Occasionally, this sequence is used throughout the system; for others, one voltage level may be a, b, c , and another voltage level, a, c, b . The specific phase sequence is only a name designation that was established arbitrarily early in the history of a company, and it is difficult to change after many years of operation.

Knowledge of the existing phase sequence is very important in three-phase connections of relays and other equipment; therefore, it should be clearly indicated on the drawings and information documents. This is especially true if it is not a, b, c . The connections from a, b, c to a, c, b or vice versa can generally be made by completely interchanging phases b and c for both the equipment and the connections.

3.5 POLARITY

Polarity is important in transformers and in protection equipment. A clear understanding of polarity is useful and essential for the chapters that follow.

3.5.1 TRANSFORMER POLARITY

The polarity indications for transformers are well established by standards that apply to all types of transformers. There are two varieties of polarity: subtractive and additive. Both follow the same rules. Power and instrument transformers are subtractive, whereas some distribution transformers are additive. The polarity marking can be a dot, a square, or an X , or it can be indicated by the standardized transformer terminal markings, the practices varying over the years. Polarity designated by an X in this book.

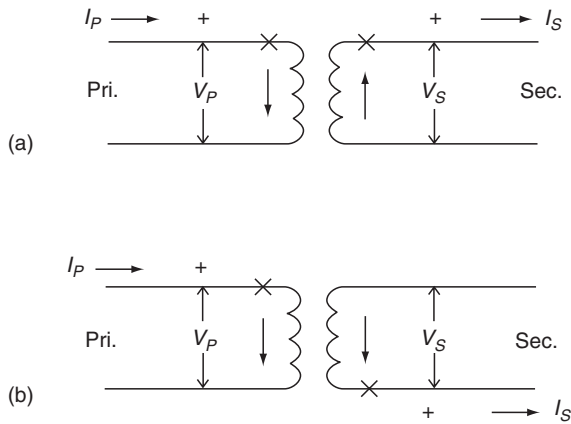

FIGURE 3.4 Polarity definitions for transformers: (a) Subtractive polarity. (b) Additive polarity.

The two fundamental rules of transformer polarity, illustrated in Figure 3.4 applying to both varieties are the following:

1. Current flowing in at the polarity mark of one winding flows out of the polarity mark of the other winding. Both currents are substantially in-phase.
2. The voltage drop from polarity to nonpolarity across one winding is essentially in phase with the voltage drop from polarity to nonpolarity across the other winding(s).

The currents through and the voltages across the transformers are substantially in-phase because the magnetizing current and the impedance drop through the transformers are very small and can be considered negligible. This is normal and practical for these definitions.

The current transformer (CT) polarity markings are shown in Figure 3.5. Note that the direction of the secondary current is the same, independent of whether the polarity marks are together on one side or on the other.

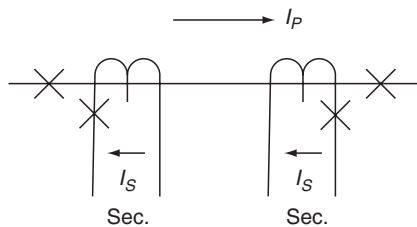

FIGURE 3.5 Polarity markings for CTs.

For CTs associated with circuit breakers and transformer banks, it is a common practice for the polarity marks to be located on the side away from the associated equipment.

The voltage-drop rule is often omitted in the definition of transformer polarity, but it is an extremely useful tool to check the phase relations through wye–delta transformer banks, or in connecting up a transformer bank for a specific phase shift required by the power system. The ANSI/IEEE standard for transformers states that the high voltage should lead the low voltage by 30° with wye–delta or delta–wye banks. Thus, different connections are required if the high side is wye than if the high side is delta. The connections for these two cases are shown in Figure 3.6. The diagrams below the three-phase transformer connection illustrate the use of the voltage-drop rule to provide or check the connections. Arrows on these voltage drops have been omitted (preferably not used), for they are not necessary and can cause confusion.

In Figure 3.6a, the check is made by noting that a to n from polarity to nonpolarity on the left-side winding is in phase with A to B from polarity to nonpolarity on the right-side winding. Similarly, b to n (polarity to nonpolarity) is in phase with B to C (polarity to nonpolarity) across the middle transformer, and c to n (polarity to nonpolarity) is in phase with C to A (polarity to nonpolarity) across the lower transformer. From this, by comparing the line-to-neutral voltages on the two sides, it is observed that phase- a -to- n voltage leads phase- A -to-neutral voltage. Accordingly, the wye side would be the high-voltage side if this is an ANSI/IEEE standard transformer.

This same technique of applying voltage drops to Figure 3.6b shows that for this three-phase bank connection the voltage-drop polarity to nonpolarity

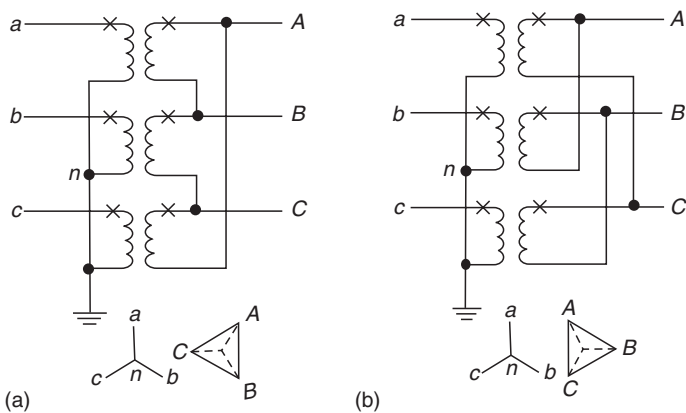

FIGURE 3.6 Voltage-drop polarity rule useful in checking or connecting wye–delta transformer banks: (a) Wye-connected side leads, delta-connected side 30° . (b) Delta-connected side leads, wye-connected side 30° .

or phase a to n is in phase with the voltage-drop polarity to nonpolarity or phase A to phase C . Similarly, voltage-drop across phase b to n is in phase with voltage-drop phase B to phase A , and voltage-drop phase c to n is in phase with voltage-drop across phase C to phase B . By comparing similar voltages on the two sides of the transformer, phase- A -to-neutral voltage drop leads the phase- a -to- n voltage drop by 30° , so the delta winding would be the high-voltage side if this is an ANSI/IEEE standard transformer bank. This technique is very useful to make the proper three-phase transformer connections from a desired or known voltage diagram or phase-shift requirement. It is a very powerful tool, which is simple and straightforward.

Because the ANSI/IEEE standards have been in existence for several years, most transformer banks in service today follow this standard, except where it is not possible because of preexisting system conditions. Many years ago, in the absence of a standard, many different connections were used. Some of the older references and textbooks reflect this.

3.5.2 RELAY POLARITY

Relays involving interaction between two input quantities from the power system may have the polarity marking that is necessary for their correct operation. There are no standards in this area, so if the polarity of the relay connections is important, the relay manufacturer must both specify the polarity markings and clearly document their meaning. Relays that sense the direction of current (or power) flow at a specific location and, thereby, indicate the direction of the fault, provide a good practical example of relay polarity. Directional units are usually not applied alone, but rather, in combinations with other units, such as fault sensors or detectors. A common practice is to use the output of the directional-sensing unit to control the operation of the fault sensors, which often is an instantaneous or an inverse-time-overcurrent unit, or both units together. Thus, if the current flow is in the desired operating direction (trip direction) and its magnitude is greater than the fault sensor's minimum-operating current (pickup), the relay can operate. If the current is in the opposite direction (nontrip or nonoperate direction or zone), no operation can occur even though the magnitude of the current is higher than the pickup threshold current.

A directional-sensing unit requires a reference quantity that is reasonably constant, against which the current in the protected circuit can be compared. For relays intended to provide operation for phase-type faults, one of the system voltages in Figure 3.3b can be used as a reference. For all practical purposes, most system voltages do not change their phase positions significantly during a fault. In contrast, line currents can shift around 180° (essentially reverse their direction or flow) for faults on one side of the circuit CTs relative to a fault on the other side of the CTs.

Typical polarity indications for three commonly used directional-sensing units are shown in Figure 3.7. This uses the custom of showing several loops

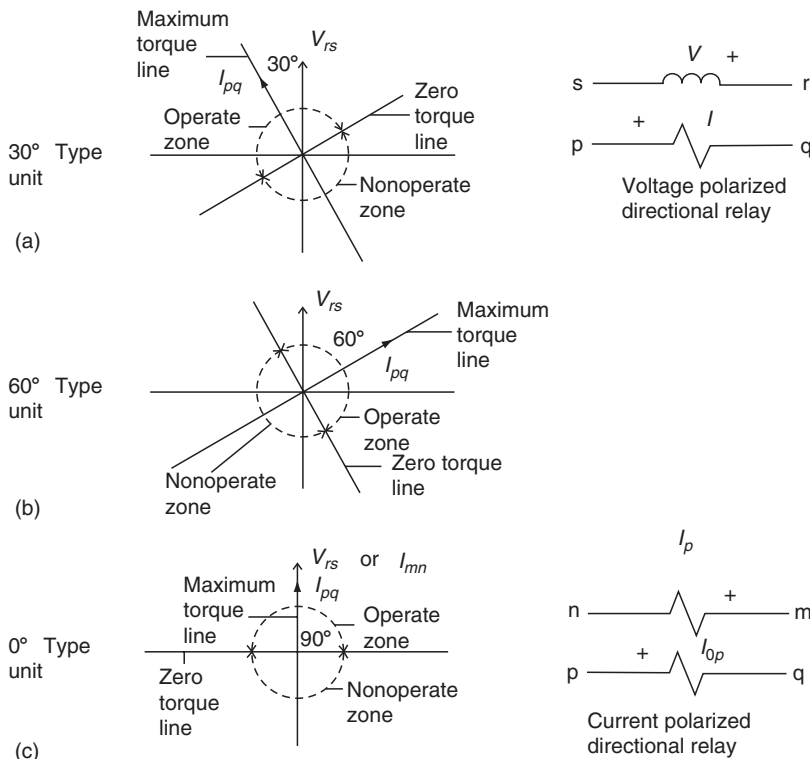

FIGURE 3.7 Typical directional relay characteristics.

for voltage coils and a single loop for current coils, of placing the reference circuit or voltage circuit above the current circuit, and of placing the polarity markings diagonally, all as shown on the relay schematics in Figure 3.7.

The reference quantity is commonly called the “polarizing” quantity, especially for ground-fault relaying, where either current polarizing or voltage polarizing is used, or both. The polarity marks (Figure 3.7) are small plus symbols (+) placed, as illustrated, above one end of each coil, diagonally as shown, or on the opposite diagonal. As shown in Figure 3.5, relay operation is not affected whether the polarity marks are on one diagonal or the other.

The meaning of the polarity for a specific relay must be stated clearly in words or by a diagram, such as the one shown in Figure 3.7. These show the basic design characteristics of an individual relay, independent of any connection or association with the power system. The terms *maximum-torque line* and *zero-torque line* come from the electromechanical designs long used and still common in the industry. With solid-state designs, these would be the operating lines or thresholds, but the well-established terminology no doubt will continue for many years for all types of designs.

The interpretation of relay polarity is illustrated in [Figure 3.7](#) for three typical electromechanical units. Solid-state units can have adjustments for (1) the maximum-torque angle and (2) the angle limits of the operate zone, but the application and operation is the same for both types. In [Figure 3.7a](#), the maximum-operating torque or energy occurs when the current flows from polarity to nonpolarity (I_{pq}) and leads by 30° the voltage drop from polarity to nonpolarity (V_{rs}). The minimum pickup of the directional unit is specified as the maximum-torque or operating condition. As seen, the unit will operate for currents from almost 60° lagging the reference voltage V_{rs} to almost 120° leading. The operate (trip, contact close) zone or area is represented by the half plane, bordered on one side by the zero-torque (nonoperating) line and extending in the direction that contains both the reference (polarizing) and operating quantities. Higher-current values will be required when I_{pq} deviates from the maximum-torque line. The solid-state relays can adjust this torque line for increased sensitivity by adjusting it to the fault line. The operating torque at any angle is a function of the cosine of the angle between the current (I_{pq}) and the maximum-torque line, as well as the magnitudes of the operating quantities.

For ground-fault protection, the 60° unit in [Figure 3.7b](#) is used with a $3 V_0$ reference (see [Figure 3.9](#)) and the zero (watt) unit of [Figure 3.7c](#) with a $3 I_0$ current reference (see [Figure 3.10](#)). The unit in [Figure 3.7c](#) is also used for power or var applications. A typical application is reverse power protection for a generator.

A similar type of electromechanical directional unit, as in [Figure 3.7a](#), has its maximum-torque angle at 45° leading, instead of 30° leading. Both units are in wide use for phase-fault protection. Solid-state units with an adjustable angle feature can provide a range of angles.

3.6 APPLICATION OF POLARITY FOR PHASE-FAULT DIRECTIONAL SENSING

Several phase voltages (see [Figure 3.3b](#)) exist within the power system and are available for consideration as the reference quantity for directional laying. Five different connections for phase-fault directional sensing have been used over the years. These are outlined in [Table 3.1](#). For a number of years, connections 4 and 5 have been used almost exclusively, so these will be discussed. The other three, used in very limited applications, are outlined in [Table 3.1](#) for reference only.

Connections 4 and 5 are fundamentally the same, and they are known as the “ 90° connection.” The only difference between them is the angle that the system current lags the system voltage for maximum-operating torque or energy. Either 60° or 45° is the typical angle of the fault current for maximum energy or torque. The difference is of no significance because $\cos(60^\circ - 45^\circ) = 0.97$ and the typical pickup of these types of directional units is about 2–4 VA or less. With the normal 120 V available to the relay, this represents a current sensitivity of about

TABLE 3.1
Connection Chart for Phase-Fault Directional Sensing

Connections	Angles	Figures	Phase A		Phase B		Phase C		Maximum Torque Occurs When
			I	V	I	V	I	V	
1	30°	Figure 3.7c	I_a	V_{ac}	I_b	V_{ba}	I_c	V_{cb}	I lags 30°
2	60° delta	Figure 3.7c	$I_a - I_b$	V_{ac}	I_{bc}	V_{ba}	$I_c - I_a$	V_{cb}	I lags 60°
3	60° wye	Figure 3.7c	I_a	$-V_c$	I_b	$-V_a$	I_c	$-V_b$	I lags 60°
4	90°-60°	Figure 3.7a but maximum torque at 45°	I_a	V_{bc}	I_b	V_{ca}	I_c	V_{ab}	I lags 45°
5	90°-60°	Figure 3.7a	I_a	V_{bc}	I_b	V_{ca}	I_c	V_{ab}	I lags 60°

0.02–0.04 A. As a result, the normal power load in the operating zone will operate the phase directional units, but the relay will not operate unless a fault has occurred to increase the current above the fault-sensing unit's pickup. Again, the solid-state units can have an adjustable maximum-torque line.

3.6.1 90°–60° CONNECTION FOR PHASE-FAULT PROTECTION

The 90° connection (see connections 4 and 5 of Table 3.1) applies a power system voltage that lags the power system *unity power factor* current by 90°. These voltages and currents are obtained from the power system through voltage and CTs. Typical three-phase connections are shown in Figure 3.8. Three separate units are used, one for each of the three phases of the power

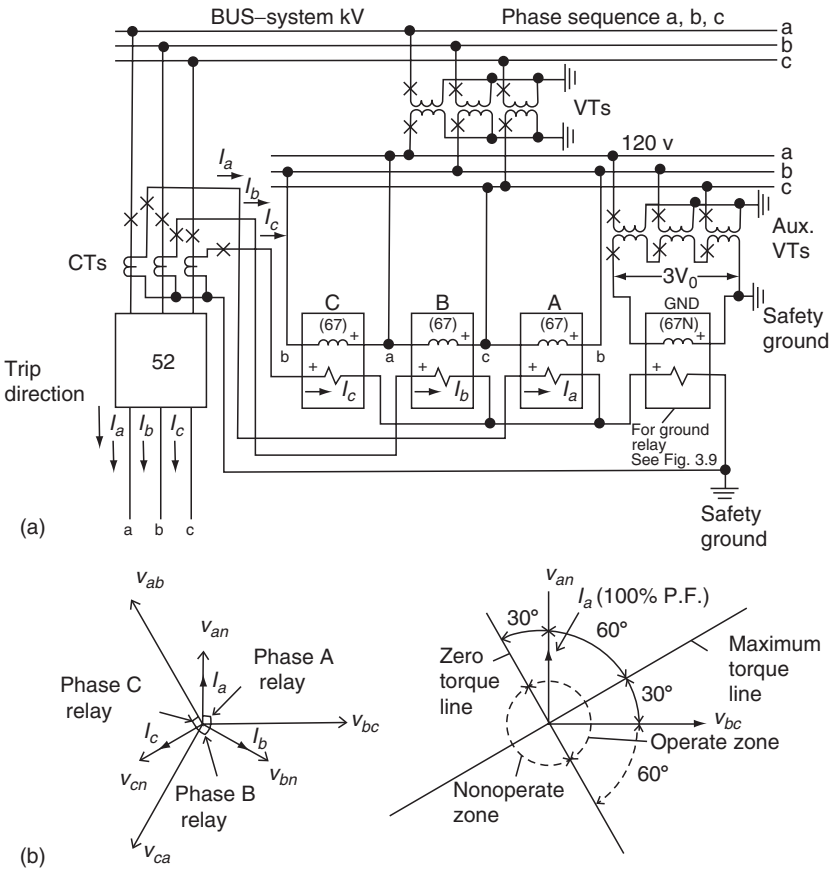

FIGURE 3.8 (a) Typical three-line connections for phase-fault directional sensing using the 30° unit of Figure 3.7a. (b) Connections also show the ground-fault directional sensing using the 60° unit of Figure 3.7b. More details and phasor diagram are shown in Figure 3.9.

system. Only the directional-sensing units are illustrated, with the fault sensors or detectors omitted for this discussion. They are shown packaged by phase, but other packaging combinations are possible.

The phase *A* directional unit receives I_a , and from the system phasors of Figure 3.3b, the 90° lagging voltage is V_{bc} . The phase *B* directional unit receives I_b where the 90° lagging voltage is V_{ca} , and the phase *C* directional unit receives I_c where the 90° lagging voltage is V_{ab} . These are also shown in Table 3.1 for connections 4 and 5 and in Figure 3.8.

In Figure 3.8a the currents are connected so that when I_a , I_b , and I_c are flowing in the direction indicated by the “trip direction” arrow, the secondary currents flow through the directional units from polarity to nonpolarity. The polarity of the CTs does not have to go to the polarity of the relay, although often that is convenient, as in this example.

With the trip direction of the currents established in the directional unit current coils, the voltages V_{bc} on unit A, V_{ca} on unit B, and V_{ab} on unit C must be connected from polarity to nonpolarity on the directional unit voltage coils, as shown. The right-hand phasor diagram of Figure 3.8b applies the directional unit characteristic of Figure 3.7a to the power system phasors. The maximum-torque line leads the voltage by 30°, so with V_{bc} polarity to nonpolarity on the relay voltage winding, the maximum-torque line is drawn 30° leading, as illustrated in the lower right-hand phasor diagram. This is 60° lagging the unity power factor position of the current phasor I_a . Therefore, whenever the phase *a* current in the power system lags by 60°, the directional unit will operate at maximum torque with the lowest pickup value and the highest sensitivity. Because most system faults provide relatively large currents, the range of possible operation is for power system currents from almost 30° leading to 150° lagging in the trip direction. This is the operating zone shown in Figure 3.8. Similar relations exist for the other two-phase units using I_b and I_c phase currents.

Thus, the foregoing discussion describes the 90°–60° connection, where a 90° lagging voltage is used, and maximum operation occurs when the phase current lags in the system by 60°. The 90°–45° connection is identical, except that the relay design provides maximum torque, leading the reference voltage by 45°, rather than by 30°, used for illustration.

Solid-state relays provide the possibility of restricting the operating zone. For most power system faults, the current will lag the fault voltage from close to say 5°–15° (large arc resistance at low voltages) to 80°–85° at the high voltages; thus, restricting the operating one by adjusting the zero-torque lines is practicable.

Wye–wye connected voltage transformers (VTs) are shown in the typical connections of Figure 3.8a. Open-delta connections using only two VTs to provide three-phase voltage can be used as an alternative. This is applicable only for phase-fault protection, not for ground protection.

3.7 DIRECTIONAL SENSING FOR GROUND FAULTS: VOLTAGE POLARIZATION

The connections of a directional-sensing unit for ground-fault protection using a voltage reference (voltage polarization) are shown in Figure 3.8a and in greater detail in Figure 3.9. Although the phase relays of Section 3.6

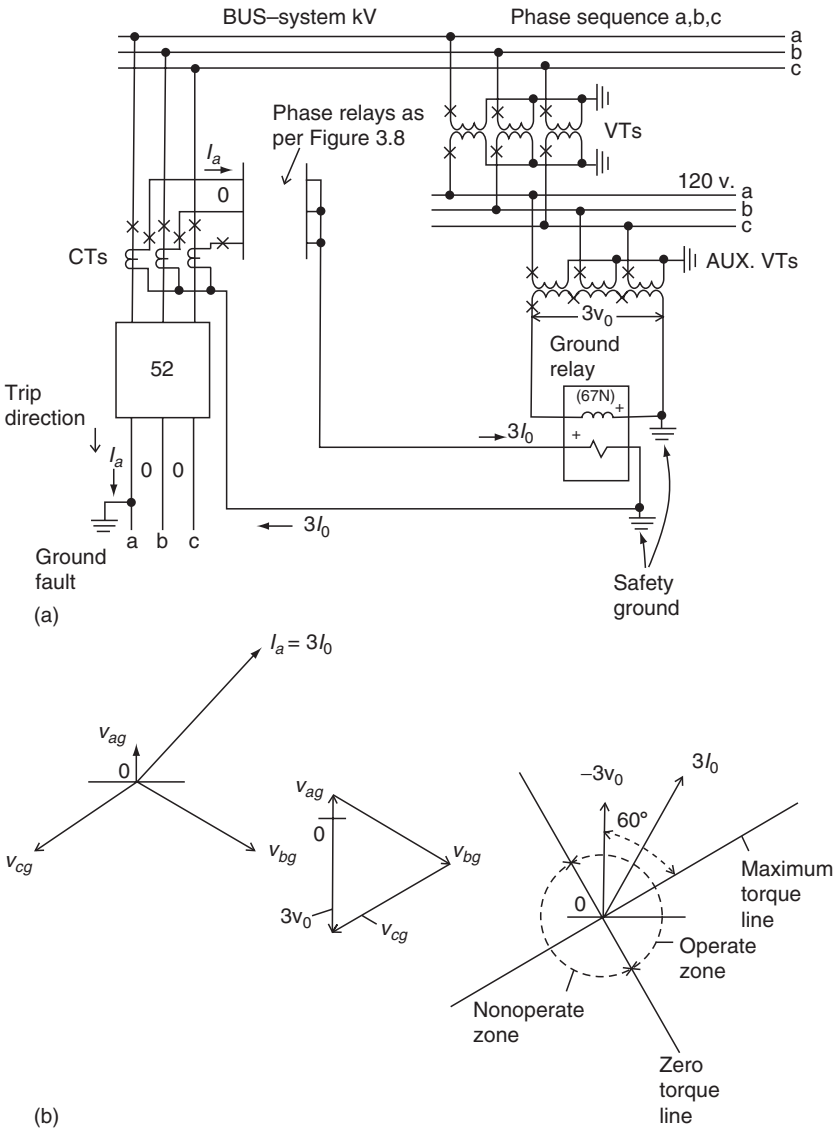

FIGURE 3.9 Typical three-line connections for ground-fault directional sensing with voltage polarization using the 60° unit of Figure 3.7b.

were connected and analyzed using balanced three-phase voltages and currents, it is necessary to assume a fault involving the ground for a ground relay. Thus, a phase-*a*-to-ground fault is assumed in the trip direction, as shown in Figure 3.9. The characteristics of this type of fault generally are a collapse of the faulted-phase voltage (V_{ag}) with an increase in and lag of the faulted-phase current (I_a), such as typically illustrated in the left phasor diagram. In many cases the unfaulted (*b* and *c*) phase currents are small and negligible practically, so that their phase-to-ground voltages are essentially uncollapsed. The assumption here is that $I_b = I_c = 0$, so that $I_a = 3I_0$. This, together with V_0 or $3V_0$, is a zero-sequence quantity, reviewed in Chapter 4.

In Figure 3.9, a voltage polarizing (voltage reference) is shown that uses the $3V_0$ zero-sequence voltage derived from a broken-delta connection of the VTs (in this example, the auxiliary VTs). This voltage is the sum of the three-phase-to-ground voltages, as shown in the connections and in middle phasor diagram. For balanced conditions this $3V_0$ voltage is zero.

For ground-fault protection, a directional 60° unit (see Figure 3.7b) is used. The connections show that with I_a fault current flowing in the tripping direction and to the fault, the secondary current flows in the ground relay from its polarity-to-nonpolarity direction. To provide proper operation, it becomes necessary to apply $-3V_0$ to the ground relay voltage coil from polarity to nonpolarity, as shown in the connections and the right phasor diagram, where the operation is as indicated. With $-3V_0$ connected to the ground relay from polarity to nonpolarity, the relay characteristics in Figure 3.7b indicate that maximum torque will occur when the current polarity-to-nonpolarity lags in the power system by 60° . Thus, the maximum-torque line is drawn as shown in the lower-right phasor diagram of Figure 3.9. As long as the magnitudes of $-3V_0$ and $3I_0$ are above the pickup of the directional unit, it will operate for currents from nearly 30° leading to 150° lagging.

Ground faults on power systems, as do phase-faults, lag the fault voltage up to about 80° – 85° ; therefore, solid-state relays in which the zero-torque lines can be changed are useful to limit the operating zone from that shown in Figure 3.9.

An alternative check of these connections may be made by assuming that the VTs are a ground source with current flowing from the ground through the primary of the VT to the fault. If one traces this through the VT windings, this assumed current together with the fault current from the system, will flow from polarity to nonpolarity in both of the ground relay windings.

3.8 DIRECTIONAL SENSING FOR GROUND FAULTS: CURRENT POLARIZATION

The current that flows in the grounded neutral of a wye–delta power or distribution transformer bank can be used as a reference or polarizing quantity

for ground-fault protection. Typical connections are shown in Figure 3.10. Again, no current can flow to the ground relay either from the fault or from the transformer bank neutral if the power system is balanced. Thus, a phase-*a*-to-ground fault is shown on phase *a* in the trip direction. For simplification, I_b and I_c phase currents are assumed to be zero. For all practical purposes the current flowing into the fault will be essentially in phase with the current flowing up the transformer bank neutral, so the 0° -type ground relay, with characteristics as shown in Figure 3.7c, is applicable and is the one used in the connections in Figure 3.10.

To illustrate and emphasize that the polarity marks on the CTs do not have to be connected to the polarity-marked terminal of the relay, the fault I_a current from the CTs on the line have been connected arbitrarily so that I_a flows from nonpolarity to polarity on the relay coil. Therefore, the polarizing secondary current I_a must be connected from nonpolarity to polarity when the primary fault I_n flows up the neutral of the transformer.

With the currents I_a and I_n in phase, maximum-operating torque will occur as in Figure 3.7c. Operation is still possible, as one current leads or lags by almost 90° from the other, as long as the magnitudes are higher than the

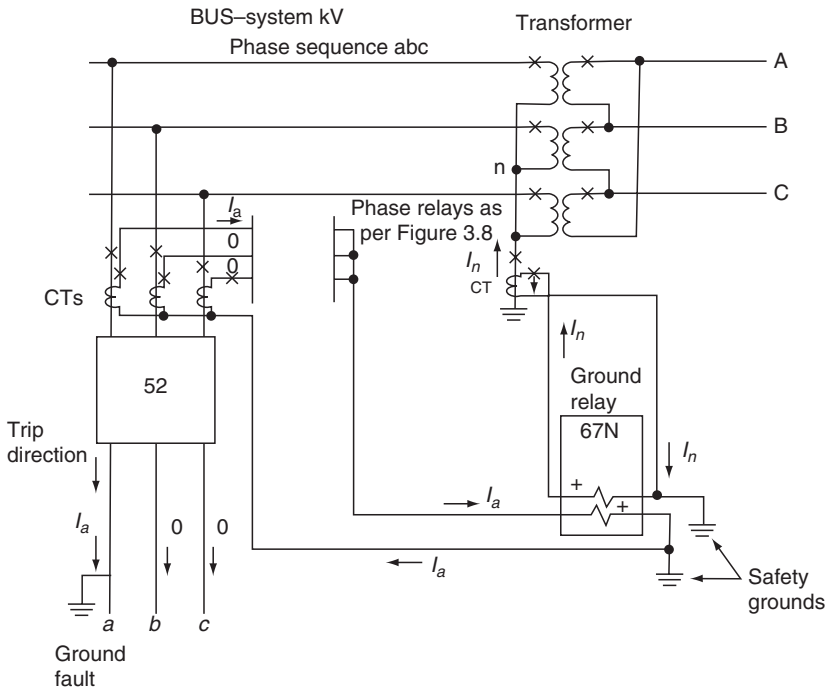

FIGURE 3.10 Typical three-line connections for ground-fault directional sensing with current polarization using the 0° unit of Figure 3.7c.

required pickup values for the directional unit. It should be obvious that the connections of Figure 3.10 are also correct (also for Figure 3.9) if the operating quantity I_a ($3I_0$) and the polarizing quantity are both reversed at the directional relay.

3.9 OTHER DIRECTIONAL-SENSING CONNECTIONS

Various other directional-sensing connections can be derived to measure different power factor areas by connecting the different (or other) units of Figure 3.7 to various combinations of currents or current and voltage. One type of connection is used to operate on power, either watts or vars, flowing in the power system. These relays (designated device 32) are available with various operating power levels.

For watt measurement, the 0° unit of Figure 3.7c can be used with star (or delta) current or voltage. For example, this unit, used with I_a phase current and V_{an} voltage, will give maximum torque when these two quantities are in phase. Moreover, $I_a - I_b$ with V_{ab} could be used. For var measurement, I_a with V_{bc} provides maximum torque when I_a lags by 90° and zero torque when I_n is at unity power factor and flowing in either direction.

A watt-power relay (32) can also be obtained by using the 30° unit of Figure 3.7a with I_a and V_{ac} . This places the maximum-torque line in phase with the unit power factor position of I_a . Similarly, a var-type relay can be obtained using this 30° unit with I_a and V_{bn} . This provides maximum torque when I_a lags by 90° .

3.10 APPLICATION ASPECTS OF DIRECTIONAL RELAYING

Directionality enhances performance of overcurrent relaying when such relays are applied in a networked or looped system. In such systems, fault current flowing through a line terminal can be in the forward direction into the line or in the reverse direction depending on the location of the fault in the system. Line relays typically need to operate only for faults in the forward direction, which could potentially be located on the protected line. Providing directionality to such relays so that they only respond to current flows into the line could result in settings on the associated overcurrent relay that are either lower in pickup or faster in operating speed, or both. Such improvement is made possible by the fact that application of directionality reduces the number of coordination cases that need to be considered. In addition to controlling operation of overcurrent relays, directional elements are also often used to supervise operation of distance relays and pilot relay systems as a means to enhance security.

When applying directional elements, it is important to consider the expected phase angles of fault currents that are desired to be detected. The directional relaying system needs to be designed to operate for all expected

phase angles of such currents. This requires consideration of the internal maximum-torque angle designed into the relay and the related connection of voltage and CTs that supply the relay. Such consideration results in identifying the overall range of phase angles for which the overall directional relaying system will operate.

It is also important to consider the sensitivity of the directional element when applying directional relaying. Sensitivity is a measure of the minimum input quantities required to cause the device to operate. Sensitivity of directional elements is typically expressed in terms of voltampere, voltage, and current limits. In the case of electromechanical relays, a minimum amount of energy is required to supply torque to overcome restraint that is exerted by the spring that holds the directional contact in the open position. Such spring tension is necessary to assure that these contacts remain securely in the open position during conditions under which operation is undesired. Sensitivity requirements for electromechanical relays are usually expressed in terms of minimum voltamperes. While physical torque is not developed in microprocessor relays, such relays do calculate a value that is representative of the torque. By design, this calculated value must exceed a threshold value for the directional element to produce an output. This feature provides security in microprocessor relays to prevent incorrect operation when the magnitude of operating and polarizing quantities are low to the extent that decisions on directionality are unreliable. In microprocessor relay designs, it is possible to use a minimum value of voltage or current to validate correct operation of the directional unit.

Technical aspects of directional relay applications are discussed in greater detail in [Chapter 12](#). From a general standpoint, however, the protection engineer should be alert to several issues when directional relaying is applied:

1. Polarity needs to be analyzed and properly indicated when developing wiring diagrams. Incorrect operation due to improper connections to directional elements have been the cause of many incorrect operations on power systems in the past.
2. Final verification of the proper functionality of directional relay systems should be made by in-service testing when the installation is complete. Wiring in substations can be very complex making errors highly possible. Polarity markings on related equipment can also be incorrect. Field tests that are well thought out and implemented are critical in assuring that directional relay systems will function properly.
3. Minimum sensitivity of directional elements needs to be considered when applying directional relays. Sensitivity limits may cause the ability to detect restricted-type faults to be less than desired. Unequal sensitivity levels can also result in miscoordination between directional relays.

4. In general, it is best to utilize directional control only if setting benefits result. Directional elements add complication and reduce dependability of the relaying system and should therefore be utilized only when setting improvements are provided.

3.11 SUMMARY

The fundamental methodology of phasors and polarity reviewed in this chapter will be employed throughout the rest of the book. As stressed previously, these concepts are essential as useful aids in the selection, connection, operation, performance, and testing of the protection for all power systems.

4 Symmetrical Components: A Review

4.1 INTRODUCTION AND BACKGROUND

The method of symmetrical components provides a practical technology for understanding and analyzing the operation of a system during power unbalanced conditions, such as those caused by faults between phases and ground, open phases, unbalanced impedances, and so on. In addition, many protective relays operate from symmetrical component quantities. Thus, a good understanding of this subject is of great value and another very important tool in protection.

In a sense, symmetrical components can be called the language of the relay engineer or technician. Its value is both in thinking or visualizing unbalances, and it is a means of detailed analysis of them from the system parameters. In this, it is like a language in that it requires experience and practice for each access and application. Faults and unbalances occur infrequently and many do not require detailed analysis, so it becomes difficult to practice the language. This has increased with the ready availability of fault studies by computers. These provide rapid access to voluminous data, often with little understanding of the background or method that provides the data. Hence, this review of the method is intended to provide the fundamentals, basic circuits and calculations, and an overview directed at clear understanding and visualization.

The method of symmetrical components was discovered by Charles L. Fortescue, who was mathematically investigating the operation of induction motors under unbalanced conditions, late in 1913. At the 34th Annual Convention of the AIEE—on June 28, 1918, in Atlantic City—he presented an 89-page paper entitled “Method of Symmetrical Co-ordinates Applied to the Solution of Polyphase Networks.” The six discussants, including Charles Proteus Steinmetz, added 25 pages. Practical application for system fault analysis was developed by C.F. Wagner and R.D. Evans in the later part of 1920s and early 1930s, with W.A. Lewis adding valuable simplifications in 1933. Tables of fault and unbalance connections were provided by E.L. Harder in 1937. At the same time Edith Clarke was also developing notes and lecturing in this area, but formal publication of her work did not occur until 1943. Additional material and many examples for further study are found in Blackburn (1993).

Only symmetrical components for three-phase systems are reviewed in this chapter. For these systems there are three distinct sets of components: positive, negative, and zero for both current and voltage. Throughout this discussion, the sequence quantities are always line-to-neutral or line-to-ground and appropriate to the situation. This is an exception for voltage connections, whereas while in the power system line-to-line voltages are commonly indicated, in symmetrical components they are always given as line-to-neutral (or possibly line-to-ground).

4.2 POSITIVE-SEQUENCE SET

The positive-sequence set consists of balanced three-phase currents and line-to-neutral voltages supplied by the system generators. Thus, they are always equal in magnitude and are phase-displaced by 120° . Figure 4.1 shows a positive-sequence set of phase currents, with the power system phase sequence in the order of a , b , c . A voltage set is similar, except for line-to-neutral voltage of the three phases, with equal magnitude and which displaces at 120° . These are phasors that rotate in the counterclockwise direction at the system frequency.

To document the angle displacement, it is convenient to use a unit phasor with an angle displacement of 120° . This is designated as a so that

$$\begin{aligned} a &= 1 \angle 120^\circ = -0.5 + j0.866 \\ a^2 &= 1 \angle 240^\circ = -0.5 - j0.866 \\ a^3 &= 1 \angle 360^\circ = 1 \angle 0^\circ = 1.0 + j0. \end{aligned} \quad (4.1)$$

Therefore, the positive-sequence set can be designated as

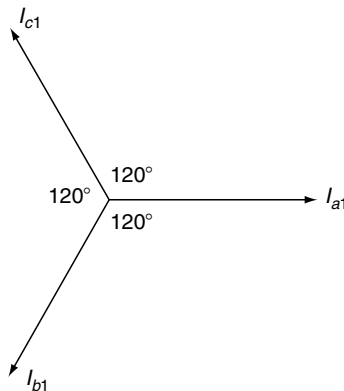

FIGURE 4.1 Positive-sequence current phasors. Phasor rotation is counterclockwise.

$$\begin{aligned}
 I_{a1} &= I_1 \quad V_{a1} = V_1, \\
 I_{b1} &= a^2 I_{a1} = a^2 I_1 = I_1 \angle 240^\circ \quad V_{b1} = a^2 V = V_1 \angle 240^\circ, \\
 I_{c1} &= a I_{a1} = a I_1 = I_1 \angle 120^\circ \quad V_{c1} = a V_1 = V_1 \angle 120^\circ.
 \end{aligned} \tag{4.2}$$

It is most important to emphasize that the set of sequence currents or sequence voltages always exists as defined. The phasors I_{a1} or I_{b1} or I_{c1} can never exist alone or in pairs, but always as a set of three. Thus, it is necessary to define only one of the phasors (any one) from which the other two will be as documented in Equation 4.2.

4.3 NOMENCLATURE CONVENIENCE

It will be noted that the designation subscript for phase a was dropped in the second expression for the currents and voltages in Equation 4.2 (and also in the following equations). This is a common shorthand notation used for convenience. When the phase subscript is not mentioned, it can be assumed that the reference is to phase a . If phase b or phase c quantities are intended, the phase subscript must be correctly designated; otherwise, it is assumed as phase a . This shortcut will be used throughout the book and is common in practice.

4.4 NEGATIVE-SEQUENCE SET

The negative-sequence set is also balanced with three equal magnitude quantities at 120° separately, but only when the phase rotation or sequence is reversed as illustrated in Figure 4.2. Thus, if positive sequence is a, b, c ; negative will be a, c, b . When positive sequence is a, c, b , as in some power systems; negative sequence is a, b, c .

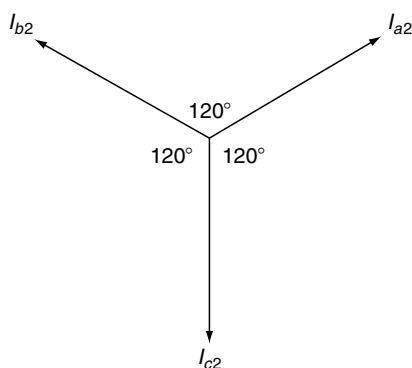

FIGURE 4.2 Negative-sequence current phasors. Phasor rotation is counterclockwise.

The negative-sequence set can be designated as

$$\begin{aligned} I_{a2} &= I_2 \quad V_{a2} = V_2, \\ I_{b2} &= aI_{a2}aI_2 = I_2 \angle 120^\circ \quad V_{b2} = aV_2 = V_2 \angle 120^\circ, \\ I_{c2} &= a^2I_{a2}a^2I_2 = I_2 \angle 240^\circ \quad V_{c2} = a^2V_2 = V_2 \angle 240^\circ. \end{aligned} \quad (4.3)$$

Again, negative sequence always exists as a set of current or voltage as defined in the foregoing or as shown in Figure 4.2: I_{a2} or I_{b2} or I_{c2} can never exist alone. When one current or voltage phasor is known, the other two of the set can be defined as mentioned earlier.

4.5 ZERO-SEQUENCE SET

The members of this set of rotating phasors are always equal in magnitude and exist in phase (Figure 4.3).

$$I_{a0} = I_{b0} = I_{c0} = I_0 \quad V_{a0} = V_{b0} = V_{c0} = V_0. \quad (4.4)$$

Similarly, I_0 or V_0 exists equally in all three phases, but never alone in a phase.

4.6 GENERAL EQUATIONS

Any unbalanced current or voltage can be determined from the sequence components given in the following fundamental equations:

$$I_a = I_1 + I_2 + I_0, \quad V_a = V_1 + V_2 + V_0, \quad (4.5)$$

$$I_b = a^2I_1 + aI_2 + I_0, \quad V_b = a^2V_1 + aV_2 + V_0, \quad (4.6)$$

$$I_c = aI_1 + a^2I_2 + I_0, \quad V_c = aV_1 + a^2V_2 + V_0, \quad (4.7)$$

where I_a , I_b , and I_c or V_a , V_b , and V_c are general unbalanced line-to-neutral phasors.

From these, equations defining the sequence quantities from a three-phase unbalanced set can be determined:

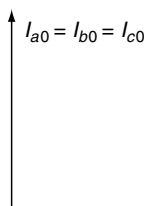

FIGURE 4.3 Zero-sequence current phasors. Phasor rotation is counterclockwise.

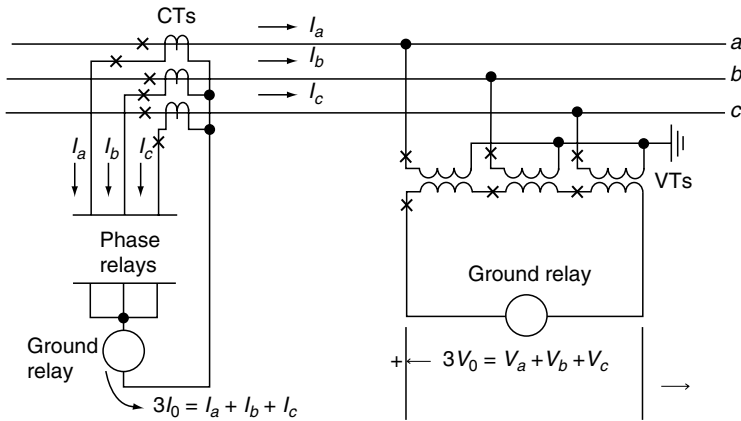

FIGURE 4.4 Zero-sequence current and voltage networks used for ground-fault protection. See Figure 3.9 and Figure 3.10 for typical fault operations.

$$I_0 = \frac{1}{3}(I_a + I_b + I_c), \quad V_0 = \frac{1}{3}(V_a + V_b + V_c), \quad (4.8)$$

$$I_1 = \frac{1}{3}(I_a + aI_b + a^2I_c), \quad V_1 = \frac{1}{3}(V_a + aV_b + a^2V_c), \quad (4.9)$$

$$I_2 = \frac{1}{3}(I_a + a^2I_b + aI_c), \quad V_2 = \frac{1}{3}(V_a + a^2V_b + aV_c). \quad (4.10)$$

These three fundamental equations are the basis for determining if the sequence quantities exist in any given set of unbalanced three-phase currents or voltages. They are used for protective-relaying operations from the sequence quantities. For example, Figure 4.4 shows the physical application of current transformers (CTs) and voltage transformers (VTs) to measure zero sequence as required in Equation 4.8 and as used in ground-fault relaying.

Networks operating from CTs or VTs are used to provide an output proportional to I_2 or V_2 and are based on physical solutions (Equation 4.10). This can be accomplished with resistors, transformers, or reactors, by digital solutions of Equation 4.8 through Equation 4.10.

4.7 SEQUENCE INDEPENDENCE

The factor that makes the concept of dividing the unbalanced three-phase quantities into the sequence components practical is the independence of the components in a balanced system network. For all practical purposes, electric power systems are balanced or symmetrical from the generators to the point of single-phase loading, except in an area of a fault or unbalance, such as an

open conductor. In this effectively balanced area, the following conditions exist:

1. Positive-sequence currents flowing in the symmetrical or balanced network produce only positive-sequence voltage drops, no negative- or zero-sequence drops.
2. Negative-sequence currents flowing in the balanced network produce only negative-sequence voltage drops, no positive- or zero-sequence voltage drops.
3. Zero-sequence currents flowing in the balanced network produce only zero-sequence voltage drops, no positive- or negative-sequence voltage drops.

This is not true for any unbalanced or nonsymmetrical point or area, such as an unsymmetrical fault, open phase, and so on.

4. Positive-sequence current flowing in an unbalanced system produces positive-, negative-, and possibly zero-sequence voltage drops.
5. Negative-sequence currents flowing in an unbalanced system produces positive-, negative-, and possibly zero-sequence voltage drops.
6. Zero-sequence current flowing in an unbalanced system produces all three: positive-, negative-, and zero-sequence voltage drops.

This important fundamental condition permits setting up three independent networks, one for each of the three sequences, which can be interconnected only at the point or area of unbalance. Before continuing with the sequence networks, a review of the source of fault current is useful.

4.8 POSITIVE-SEQUENCE SOURCES

A single-line diagram of the power system or area under study is the starting point for setting up the sequence networks. A typical diagram for a section of a power system is shown in [Figure 4.5](#). In these diagrams, circles are used to designate the positive-sequence sources, which are the rotating machines in the system; generators, synchronous motors, synchronous condensers, and probably induction motors. The symmetrical current supplied by these to the power-system faults decreases exponentially with time from a relatively high initial value to a low steady-state value. During this transient period three reactance values are possible for use in the positive-sequence network and for the calculation of fault currents. These are the direct-axis subtransient reactance X''_d , the direct-axis transient reactance X'_d , and the unsaturated direct-axis synchronous reactance X_d .

The values of these reactances vary with the designs of the machines and the specific values are supplied by the manufacturer. In their absence, typical

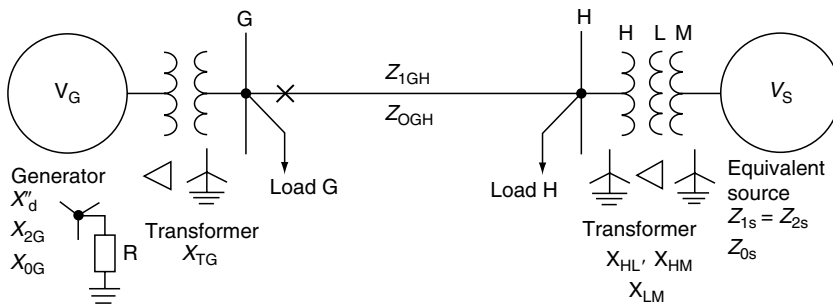

FIGURE 4.5 Single-line diagram of a section of a power system.

values are shown in Blackburn (1993, p. 279) and in many other references. Generally, typical values at the machines rated MVA (kVA) and kV are: $X_d'' = 0.1$ to 0.3 pu, with time constants of about 0.35 sec; $X_d' = 1.2 - 2.0$ times X_d'' , with time constants in the order of $0.6 - 1.5$ sec; X_d for faults is the unsaturated value that can range from 6 to 14 times X_d'' .

For system-protection fault studies, the almost universal practice is to use the subtransient (X_d'') for the rotating machines in the positive-sequence networks. This provides a maximum value of fault current that is useful for high-speed relaying. Although slower-speed protection may operate after the subtransient reactance has decayed into the transient reactance period, the general practice is to use X_d' , except possibly for special cases where X_d would be used. There are special programs to account for the decremental decay in fault current with time in setting the slower-speed protective relays, but these tend to be difficult and tedious, and may not provide any substantial advantages. A guide to aid in the understanding of the need for special considerations is outlined in Figure 4.6. The criteria are very general and approximate.

Cases A and B (see Figure 4.6) are the most common situations, so that the use of X_d'' has a negligible effect on the protection. Here the higher system Z_s tends to negate the source decrement effects.

Case C (see Figure 4.6) can affect the overall operation time of a slower-speed protection, but generally the decrease in fault current level with time will not cause coordination problems unless the time-current characteristics of various devices that are used are significantly different. When Z_M predominates, the fault levels tend to be high and well above the maximum-load current. The practice of setting the protection as sensitive as possible, but not operating on maximum load (phase devices) should provide good protection sensitivity in the transient reactance period. If protection-operating times are very long, such that the current decays into the synchronous reactance period, special phase relays are required, as discussed in Chapter 8.

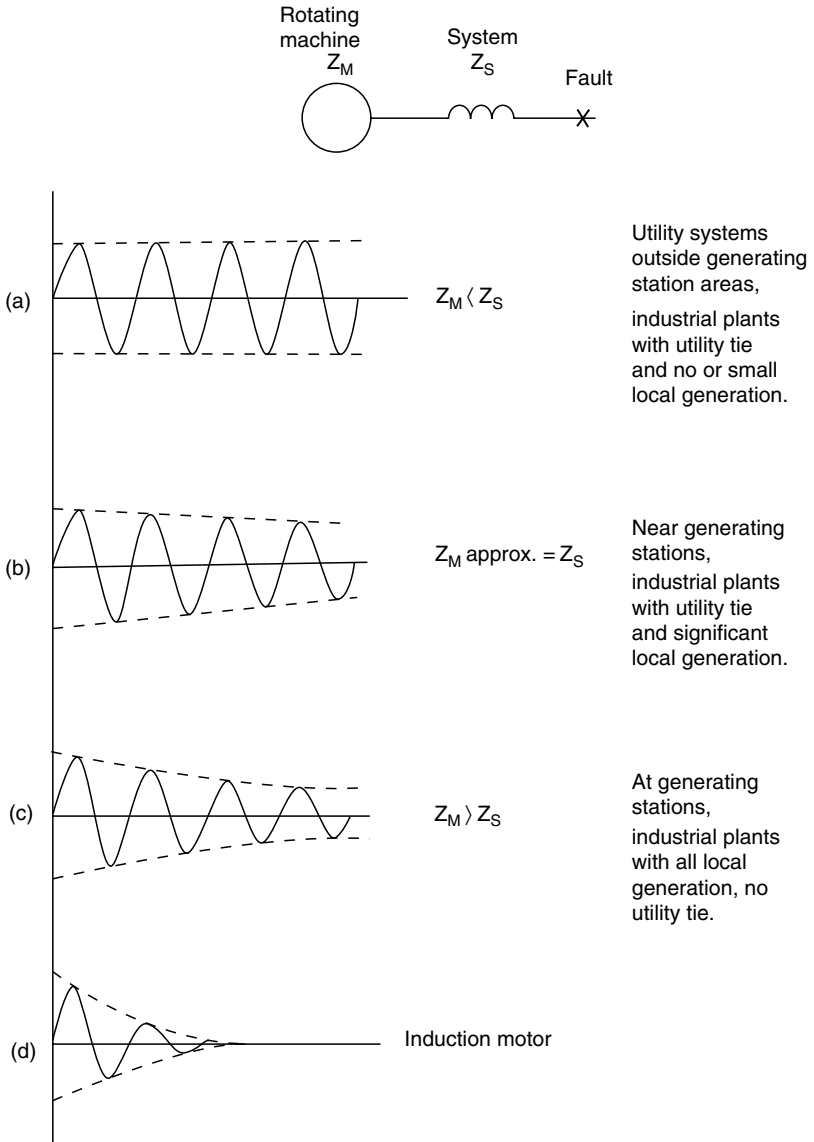

FIGURE 4.6 Guide illustrating the effects of rotating machine decrements on the symmetrical fault current.

Usually, induction motors are not considered as sources of fault current for protection purposes (see Figure 4.6, case D). However, it must be emphasized that these motors must be considered in circuit breakers' applications under the ANSI/IEEE standards. Without a field source, the voltage that is

developed by induction motors decays rapidly, within a few cycles; thus, they generally have a negligible effect on the protection. The DC offset that can result from sudden changes in current in the ac networks is neglected in symmetrical components. It is an important consideration in all protection.

An equivalent source, such as that shown in [Figure 4.5](#), represents the equivalent of all the systems that are not shown up to the point of connection to that part of the system under study. This includes one or many rotating machines that may be interconnected together with any network of transformers, lines, and so on. In general, a network system can be reduced to two equivalent sources at each end of an area to be studied, with an equivalent interconnecting tie between these two equivalent sources. When the equivalent tie is large or infinite, indicating that little or no power is exchanged between the two source systems, it is convenient to express the equivalent source system up to a specified bus or point in short-circuit MVA (or kVA). Appendix 4.1 outlines this and the conversion to the impedance or the reactance values. In [Figure 4.5](#), the network to the right has reduced to a single equivalent impedance to represent it up to the M terminal of the three-winding transformer bank.

4.9 SEQUENCE NETWORKS

The sequence networks represent one of the three-phase-to-neutral or to-ground circuits of the balanced three-phase power system and document how their sequence currents will flow if they can exist. These networks are best explained by an example: let us now consider the section of a power system in [Figure 4.5](#).

Reactance values have been indicated only for the generator and the transformers. Theoretically, impedance values should be used, but the resistances of these units are small and negligible for fault studies. However, if loads are included, impedance values should be used unless their values are small in relation to the reactances.

It is important that all values should be specified with a base [voltage if ohms are used, or MVA (kVA) and kV if per-unit or percent impedances are used]. Before applying these to the sequence networks, all values must be changed to one common base. Usually, per-unit (percent) values are used, and a common base in practice is 100 MVA at the particular system kV.

4.9.1 POSITIVE-SEQUENCE NETWORK

This is the usual line-to-neutral system diagram for one of the three symmetrical phases modified for fault conditions. The positive-sequence networks for the system in [Figure 4.5](#) are shown in [Figure 4.7](#). The voltages V_G and V_S are the system line-to-neutral voltages. V_G is the voltage behind the generator subtransient direct-axis reactance X'_d , and V_S is the voltage behind the system equivalent impedance Z_{1S} .

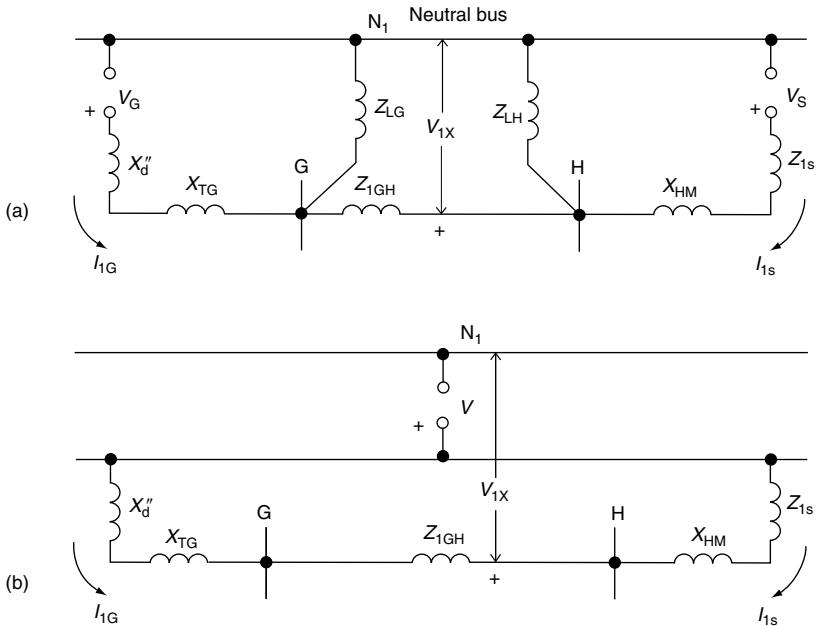

FIGURE 4.7 Positive-sequence networks for the system in Figure 4.5: (a) network including loads; (b) simplified network with no load—all system voltages equal and in phase.

X_{TG} is the transformer leakage impedance for the bank bus G, and X_{HM} is the leakage impedance for the bank at H between the H and M windings. More details on these are given in Appendix 4.2. The delta-winding L of this three-winding bank is not involved in the positive-sequence network unless a generator or synchronous motor is connected to it or unless a fault is to be considered in the L delta system. The connection would be as in Figure A4.2-3.

For the line between buses G and H, Z_{1GH} is the line-to-neutral impedance of this three-phase circuit. For open-wire transmission lines, an approximate estimating value is $0.8 \Omega/\text{mi}$ for single conductor and $0.6 \Omega/\text{mi}$ for bundled conductors. Typical values for shunt capacitance of these lines are $0.2 \text{ M}\Omega/\text{mi}$ for single conductor and $0.14 \text{ M}\Omega/\text{mi}$ for bundled conductors. Normally, this capacitance is neglected, as it is very high in relation to all other impedances that are involved in fault calculations. These values should be used either for estimating or in the absence of specific line constants. The impedances of cables vary considerably, so specific data are necessary for these.

The impedance angle of lines can vary quite widely, depending on the voltage and type of cable or open wire that is used. In computer fault programs, the angles are considered and included, but for hand calculation,

it is often practical and convenient to simplify calculations by assuming that all the equipment involved in the fault calculation is at 90° . Otherwise, it is better to use reactance values only. Sometimes it may be preferred to use the line impedance values and treat them as reactances. Unless the network consists of a large proportion of low-angle circuits, the error of using all values as 90° will not be too significant.

Load is shown to be connected at buses G and H. Normally, this would be specified as kVA or MVA and can be converted into impedance.

$$I_{\text{load}} = \frac{1000 \text{ MVA}_{\text{load}}}{\sqrt{3} \text{ kV}} \quad \text{and} \quad V_{\text{LN}} = \frac{1000 \text{ kV}}{\sqrt{3}}$$

$$Z_{\text{load}} = \frac{V_{\text{LN}}}{I_{\text{load}}} = \frac{\text{kV}^2}{\text{MVA}_{\text{load}}} = \text{ohms at kV.} \quad (4.11)$$

Equation 4.11 is a line-to-neutral value and could be used for Z_{LG} and Z_{LH} , representing the loads at G and H as shown in [Figure 4.7a](#). If load is represented, the voltages V_{G} and V_{S} will be different in magnitude and angle, varying according to the system load.

The value of load impedance is usually quite large compared with the system impedances, such that the load has a negligible effect on the faulted-phase current. Thus, it becomes practical and simplifies the calculations to neglect load for shunt faults. With no load, Z_{LG} and Z_{LH} are infinite. V_{G} and V_{S} are equal and in phase, and so they are replaced by a common voltage V as in [Figure 4.7b](#). Normally, V is considered as 1 pu, the system-rated line-to-neutral voltages.

Conventional current flow is assumed to be from the neutral bus N_1 to the area or point of unbalance. With this the voltage drop V_{lx} at any point in the network is always

$$V_{\text{lx}} = V - \sum I_1 Z_1, \quad (4.12)$$

where V is the source voltage (V_{G} or V_{S} in [Figure 4.7a](#)) and $\sum I_1 Z_1$ is the sum of the drops along any path from the N_1 neutral bus to the point of measurement.

4.9.2 NEGATIVE-SEQUENCE NETWORK

The negative-sequence network defines the flow of negative-sequence currents when they exist. The system generators do not generate negative sequence, but negative-sequence current can flow through their windings. Thus, these generators and sources are represented by an impedance without voltage, as shown in [Figure 4.8](#). In transformers, lines, and so on, the phase

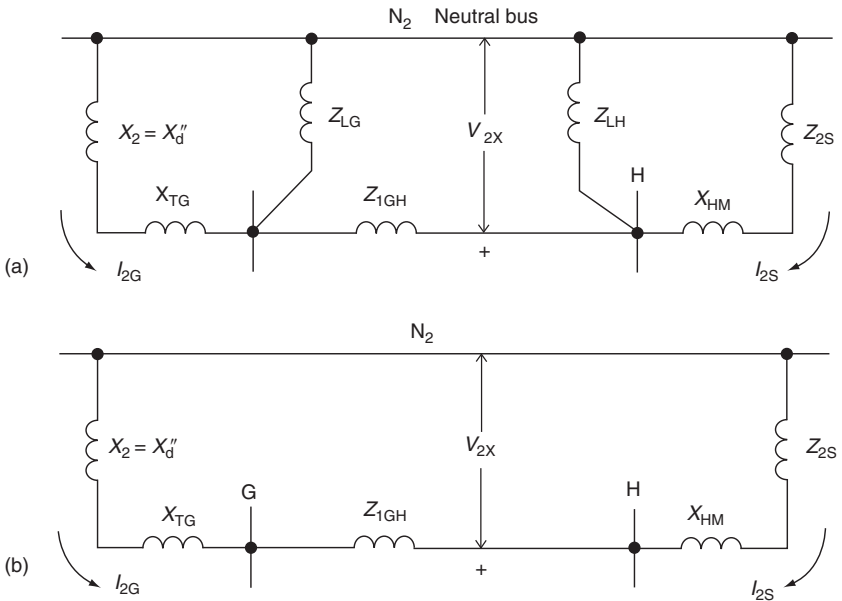

FIGURE 4.8 Negative-sequence networks for the system in Figure 4.5: (a) network including loads; (b) network neglecting loads.

sequence of the current does not change the impedance encountered; hence, the same values as in the positive-sequence network are used.

A rotating machine can be visualized as a transformer with one stationary and one rotating winding. Thus, DC in the field produces positive sequence in the stator. Similarly, the DC offset in the stator ac current produces an ac component in field. In this relative-motion model, with the single winding rotating at synchronous speed, negative sequence in the stator results in a double-frequency component in the field. Thus, the negative-sequence flux component in the air gap alternates between and under the poles at this double frequency. One common expression for the negative-sequence impedance of a synchronous machine is

$$X_2 = \frac{1}{2} (X_d'' + X_q'') \quad (4.13)$$

or the average of the direct and subtransient reactance of quadrature axes. For a round-rotor machine, $X_d'' = X_q''$, so that $X_2 = X_d''$. For salient-pole machines, X_2 will be different, but this is frequently neglected unless calculating a fault very near the machine terminals. Where normally $X_2 = X_d''$, the negative-sequence network is equivalent to the positive-sequence network except for the omission of voltages.

Loads can be shown, as in Figure 4.8a, and will be the same impedance as that for positive sequence, provided they are static loads. Rotating loads, such as

those of induction motors, have quite a different positive- and negative-sequence impedances when in operation. This is discussed further in [Chapter 11](#).

Similarly, when the load is normally neglected, the network is as shown in [Figure 4.8b](#) and is the same as the positive-sequence network (see [Figure 4.7b](#)), except that there is no voltage.

Conventional current flow is assumed to be from the neutral bus N_2 to the area or point of unbalance. With this the voltage drop V_{2x} at any point in the network is always

$$V_{2x} = 0 - \sum I_2 Z_2, \quad (4.14)$$

where $\sum I_2 Z_2$ is the sum of the drops along any path from the N_2 neutral bus to the point of measurement.

4.9.3 ZERO-SEQUENCE NETWORK

The zero-sequence network is always different. It must satisfy the flow of equal and in-phase currents in the three phases. If the connections for this network are not apparent, or in doubt, these can be resolved by drawing the three-phase system to see how the equal in-phase, zero-sequence currents can flow. For the example in [Figure 4.5](#), a three-phase diagram is shown in [Figure 4.9](#). The convention is that the current always flows to the unbalance. Therefore, assuming an unbalance between buses G and H, the top left diagram shows I_{0G} flowing from the transformer at bus G. Zero sequence

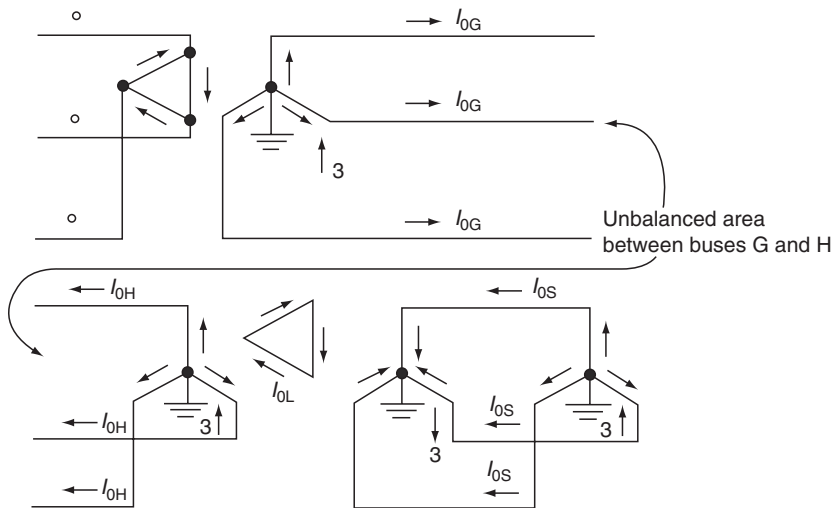

FIGURE 4.9 Diagrams illustrating the flow of zero-sequence current as an aid in drawing the zero-sequence network. Arrows indicate current directions only, not relative magnitudes.

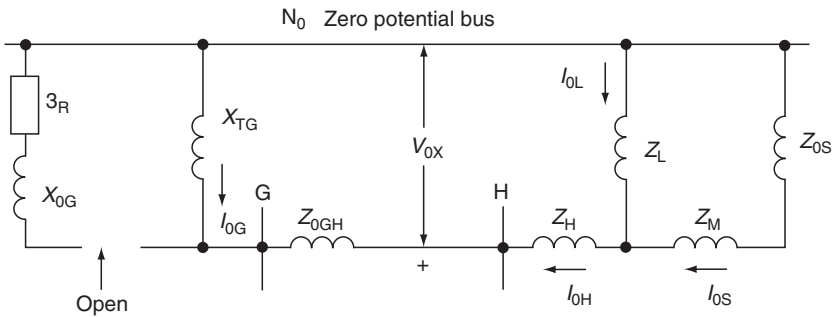

FIGURE 4.10 Zero-sequence network for the system of Figure 4.5.

can flow in the grounded wye and to the fault because there is a path for it to flow in the delta. Thus X_{TG} is connected between the zero potential bus and bus G as shown in Figure 4.10. This connection for the grounded-wye–delta transformer bank is also shown in Figure A4.2-1.

Zero-sequence impedance for transformer banks is equal to the positive and negative sequences and is the transformer leakage impedance. The exception to this is three-phase core-type transformers, for which the construction does not provide an iron flux path for zero sequence. For these the zero-sequence flux must pass from the core to the tank and return. Hence, for these types X_0 usually is 0.85–0.9 X_1 and, when known, the specific value should be used.

The lower right-hand diagram in Figure 4.9 is for the system connected to bus H (see Figure 4.5). Currents out of the three-winding transformer will flow as shown in the L and M windings. The three currents can flow in the M-grounded wye because the equivalent source is shown grounded with Z_{0S} given. Thus, the three-winding equivalent circuit is connected in the zero-sequence network (see Figure 4.10) as shown, which follows the connections documented in Figure A4.2-3b.

Note that in the right-hand part of Figure 4.9, if any of the wye connections were not grounded, the connections would be different. If the equivalent system or the M winding were ungrounded, the network would be open between Z_M and Z_{0S} , since zero-sequence currents could not flow as shown. Loads, if desired, would be shown in the zero-sequence network only if they were wye grounded; delta loads would not pass zero sequence.

Zero-sequence line impedance is always different, as it is a loop impedance: the impedance of the line plus a return path either in the earth or in a parallel combination of the earth and ground wire, cable sheath, and so on. The positive-sequence impedance is a one-way impedance from one end to the other end. As a result, zero sequence varies from two to six times X_1 for lines. For estimating open wire lines, a value of $X_0 = 3$ or $3.5 X_1$ is commonly used.

The zero-sequence impedance of generators is low and variable, depending on the winding design. Except for very low-voltage units, generators are

never solidly grounded. This is discussed in [Chapter 7](#). In [Figure 4.5](#), the generator G is shown grounded through a resistor R. Faults on bus G and in the system to the right do not involve the generator as far as zero sequence is concerned because the transformer delta blocks the flow of zero-sequence current, as shown.

Conventional current flow is assumed to be from the zero-potential bus N_0 to the area or point of unbalance. Thus, the voltage drop V_{0x} at any point in the network is always

$$V_{0x} = 0 - \sum I_0 Z_0, \quad (4.15)$$

where $\sum I_0 Z_0$ is the sum of the drops along the path from the N_0 bus to the point of measurement.

4.9.4 SEQUENCE NETWORK REDUCTION

For shunt fault calculations, the sequence networks can be reduced to a single equivalent impedance commonly designated as Z_1 or X_1 , Z_2 or X_2 , and Z_0 or X_0 from the neutral or zero-potential bus to the fault location. This is the Thevenin theorem equivalent impedance, and in the positive-sequence network, it is termed as the Thevenin voltage. These values are different for each fault location. Short-circuit studies with computers use various techniques to reduce complex power systems and to determine fault currents and voltages.

For the positive-sequence network in [Figure 4.7b](#) consider faults at bus H. Then by paralleling the impedances on either side, Z_1 becomes

$$Z_1 = \frac{(X_d'' + X_{TG} + Z_{IGH})(Z_{1S} + X_{HM})}{X_d'' + X_{TG} + Z_{IGH} + Z_{1S} + X_{HM}}.$$

Each term in parentheses in the numerator, divided by the denominator, provides a per-unit value to define the portion of current flowing in the two parts of the network. These are known as distribution factors and are necessary to determine the fault currents in various parts of the system. Thus, the per-unit current distribution through bus G is

$$I_{1G} = \frac{Z_{1S} + X_{HM}}{X_d'' + X_{TG} + Z_{IGH} + Z_{1S} + X_{HM}} \text{ pu} \quad (4.16)$$

and the current distribution through bus H is

$$I_{1H} = \frac{X_d'' + X_{TG} + Z_{IGH}}{X_d'' + X_{TG} + Z_{IGH} + Z_{1S} + X_{HM}} \text{ pu.} \quad (4.17)$$

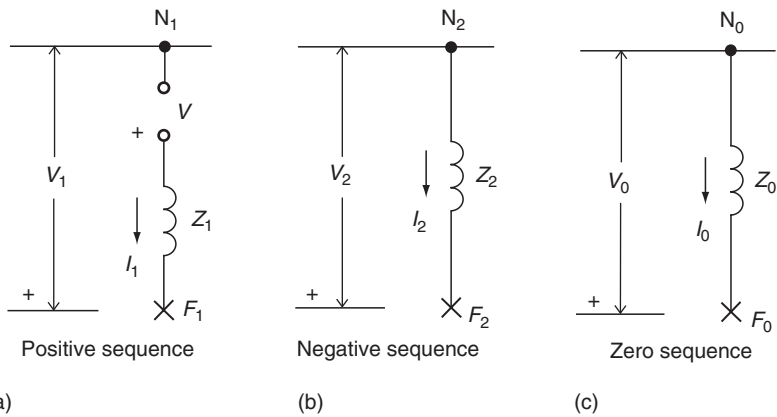

FIGURE 4.11 Reduced sequence networks where Z_1 , Z_2 , and Z_0 are the equivalent impedances of the networks to the fault point.

The reduction of the positive-sequence network with load (see Figure 4.7a) requires determining the load current flow throughout the network before a fault, determining the open-circuit voltage (Thevenin voltage) at the fault point, and then the equivalent impedance looking into the network from the fault point with all calculations. The total currents in the network are the sum of the prefault load and the fault currents.

The negative- and zero-sequence networks can be reduced in a manner similar to a single impedance to a fault point and with appropriate distribution factors. These three independent equivalent networks are shown in Figure 4.11 with I_1 , I_2 , and I_0 representing the respective sequence currents in the fault and V_1 , V_2 , and V_0 representing the respective sequence voltages at the fault.

As indicated earlier, the sequence networks, such as those shown in Figure 4.11, are completely independent of each other. Next, we discuss interconnections to represent faults and unbalances.

4.10 SHUNT UNBALANCE SEQUENCE NETWORK INTERCONNECTIONS

The principal shunt unbalances are faults: three-phase, two-phase-to-phase, two-phase-to-ground, and one-phase-to-ground. Two fault studies are normally made: (1) three-phase faults for applying and setting phase relays and (2) one-phase-to-ground faults for applying and setting ground relays. The other two faults (phase-to-phase and two-phase-to-ground) are rarely calculated for relay applications. With $Z_1 = Z_2$, as is common, then, a solid phase-to-phase fault is 0.866 of the three-phase fault.

The phase currents for solid two-phase-to-ground faults will vary depending on the zero-sequence impedances, but generally tend to be near the phase-to-phase or three-phase fault values (see Section 4.16.1).

4.10.1 FAULT IMPEDANCE

Faults are seldom solid, but involve varying amounts of resistance. However, it is generally assumed in protective relaying and most fault studies that the connection or contact with the ground involves very low and in general negligible impedance. For the higher voltages of transmission and subtransmission, this is essentially true. In distribution systems (34.5 kV and lower) a very large to basically infinite impedance can exist. This is true, particularly at the lower voltages. Many faults are tree contacts, which can be high impedance, intermittent, and variable. Conductors lying on the ground may or may not result in significant fault current and yet can be highly variable. Many tests have been conducted over the years on wet soil, dry soil, rocks, asphalt, concrete, and so on, with quite a different variable and sometimes unpredictable result. Thus, in most fault studies, the practice is to assume zero ground mat and fault impedances for maximum fault values. Protective relays are set as sensitively as possible, however, to respond properly to these maximum values.

Consequently, although arcs are quite variable, a commonly accepted value for currents between 70 and 20,000 A has been an arc drop of 440 V per phase, basically independent of current magnitude. Therefore,

$$Z_{\text{arc}} = \frac{440l}{I} \Omega \quad (4.18)$$

where l is the arc length in feet and I the current in amperes: 1/kV at 34.5 kV and higher is approximately 0.1–0.05. The arc is essentially resistance, but can appear to protective relays as an impedance, with a significant reactive component resulting from out-of-phase contributions from remote sources. This is discussed in more detail in Chapter 12. In low-voltage (480 V) switchboard-type enclosures, typical arc voltages of about 150 V can be experienced. This is relatively of current magnitude.

It appears that because arcs are variable, their resistances tend to start at a low value and continue at the same value for an appreciable time, then build up exponentially. On reaching a high value, an arc breaks over to shorten its path and resistance.

4.10.2 SUBSTATION AND TOWER-FOOTING IMPEDANCE

Another highly variable factor, which is difficult both to calculate and measure, is the resistance between a station ground mat, line pole, or tower, and the ground. In recent years several technical papers have been written, and computer programs have been developed in this area but there are still

many variables and assumptions. All this is beyond the scope of this book. The general practice is to neglect these in most fault studies and relay applications and settings.

4.10.3 SEQUENCE INTERCONNECTIONS FOR THREE-PHASE FAULTS

Three-phase faults are assumed to be symmetrical; hence, no analysis is necessary for their calculation. The positive-sequence network, which is the normal balanced diagram for a symmetrical system, can be used, and the connection is shown in Figure 4.12. For a solid fault the fault point F_1 is connected back to the neutral bus (see Figure 4.12a); with fault impedance the connection includes this impedance, as shown in Figure 4.12b. From these,

$$I_1 = I_{aF} = \frac{V}{Z_1} \quad \text{or} \quad I_1 = I_{aF} = \frac{V}{Z_1 + Z_F} \quad (4.19)$$

and $I_{bF} = a^2 I_1$, $I_{cF} = a I_1$, according to Equation 4.2. There is no difference between a three-phase fault and a three-phase-to-ground fault.

4.10.4 SEQUENCE INTERCONNECTIONS FOR SINGLE-PHASE-TO-GROUND FAULTS

A phase-*a*-to-ground fault is represented by connecting the three sequence networks together as shown in Figure 4.13, with diagram 4.13a for solid faults and 4.13b for faults with impedance. From these:

$$I_1 = I_2 = I_0 = \frac{V}{Z_1 + Z_2 + Z_0} \quad \text{or}$$

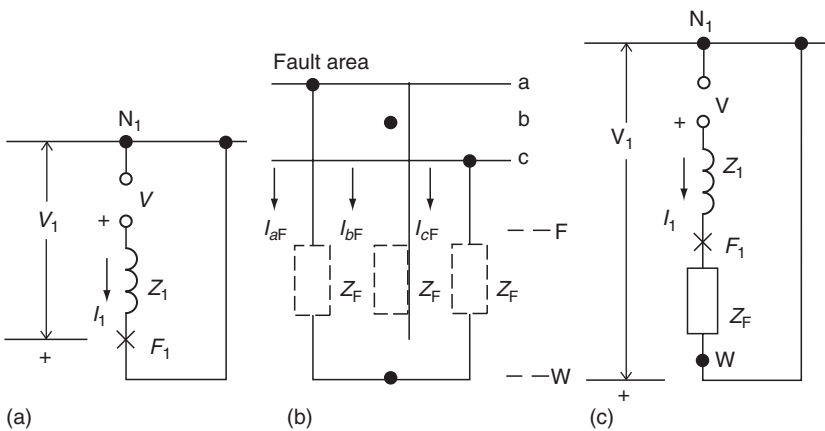

FIGURE 4.12 Three-phase fault and its sequence network interconnections: (a) solid fault; (b) system fault; (c) with fault impedance.

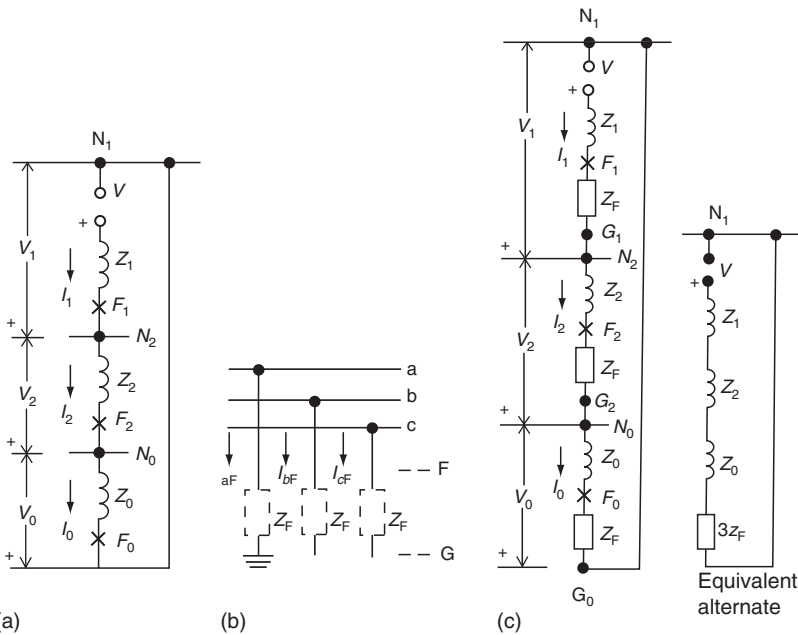

FIGURE 4.13 Single-phase-to-ground fault and its sequence network interconnections: (a) solid fault; (b) system fault; (c) with fault impedance.

$$I_1 = I_2 = I_0 = \frac{V}{Z_1 + Z_2 + Z_0 + 3Z_F}, \quad (4.20)$$

$$I_{aF} = I_1 + I_2 + I_0 = 3I_1 = 3I_2 = 3I_0. \quad (4.21)$$

From Equation 4.6 and Equation 4.7, it can be seen that $I_{bF} = I_{cF} = 0$, which is corrected in the fault. In addition, $V_{aF} = 0$, which is supported by the sequence connections because $V_1 + V_2 + V_0 = 0$.

4.10.5 SEQUENCE INTERCONNECTIONS FOR PHASE-TO-PHASE FAULTS

For this type of fault, it is convenient to show that the fault is between phases b and c . Then, the sequence connections are as shown in Figure 4.14. From these,

$$I_1 = -I_2 = \frac{V}{Z_1 + Z_2} \quad \text{or} \quad I_1 = -I_2 = \frac{V}{Z_1 + Z_2 + Z_F}. \quad (4.22)$$

From the fundamental Equation 4.5 through Equation 4.7,

$$I_{aF} = I_1 - I_2 = 0,$$

as it should be in the fault

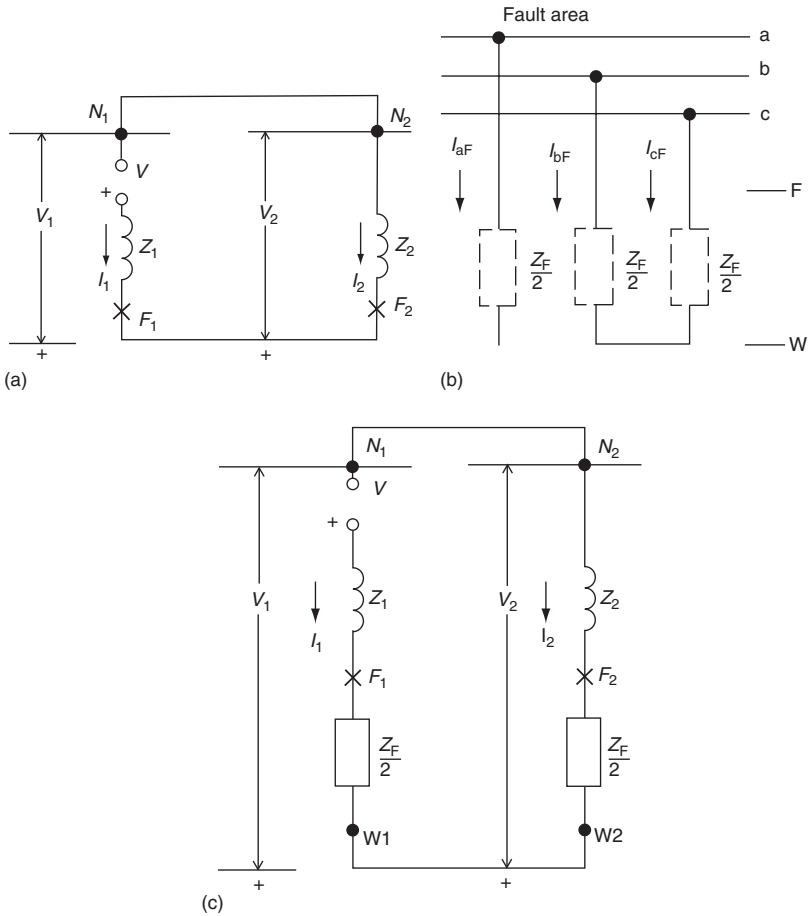

FIGURE 4.14 Phase-to-phase fault and its sequence network interconnections: (a) solid fault; (b) system fault; (c) with fault impedance.

$$I_{bF} = a^2 I_1 + a I_2 = (a^2 - a) I_1 = -j\sqrt{3} I_1, \quad (4.23)$$

$$I_{cF} = a I_1 + a^2 I_2 = (a - a^2) I_1 = +j\sqrt{3} I_1. \quad (4.24)$$

As is common, $Z_1 = Z_2$; then $I_1 = V/2Z_1$; disregarding $\pm j$ and considering only the magnitude yields

$$I_{\phi\phi} = \sqrt{\frac{3V}{2Z_1}} = 0.866, \quad \frac{V}{Z_1} = 0.866 I_{3\phi}. \quad (4.25)$$

Thus, the solid phase-to-phase fault is 86.6% of the solid three-phase fault when $Z_1 = Z_2$.

4.10.6 SEQUENCE INTERCONNECTIONS FOR DOUBLE-PHASE-TO-GROUND FAULTS

The connections for this type are similar to those for the phase-to-phase fault, but only with the addition of the zero-sequence network connected in parallel as shown in Figure 4.15. From these,

$$I = \frac{V}{Z_1 + \frac{Z_2 Z_0}{Z_2 + Z_0}}$$

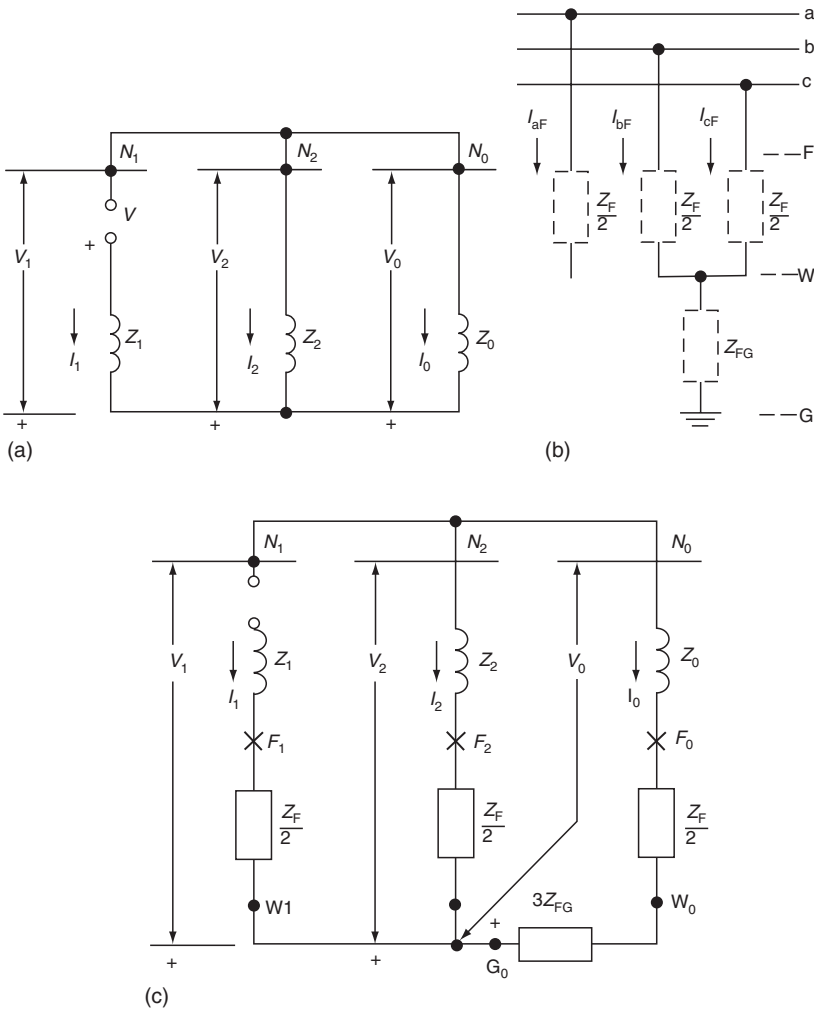

FIGURE 4.15 The double-phase-to-ground fault and its sequence network interconnections: (a) solid fault; (b) system fault; (c) with fault impedance.

or

$$I_1 = \frac{V}{Z_1 + \frac{Z_F}{2} + \frac{(Z_2 + (Z_F/2))(Z_0 + (Z_F/2) + 3Z_{FG})}{Z_2 + Z_0 + Z_F + 3Z_{FG}}}$$

$$I_2 = -I_1 \frac{Z_0}{Z_2 + Z_0} \quad \text{and} \quad I_0 = -I_1 \frac{Z_2}{Z_2 + Z_0}, \quad (4.26)$$

or

$$I_2 = -I_1 \frac{Z_0 + (Z_F/2) + 3Z_{FG}}{Z_2 + Z_0 + Z_F + 3Z_{FG}},$$

and

$$I_0 = -I_1 \frac{Z_2 + (Z_F/2)}{Z_2 + Z_0 + Z_F + 3Z_{FG}}. \quad (4.27)$$

Equation 4.5 through Equation 4.7 provide $I_{aF} = 0$ and fault magnitudes for I_{bF} and I_{cF} .

4.10.7 OTHER SEQUENCE INTERCONNECTIONS FOR SHUNT SYSTEM CONDITIONS

The impedances at the fault point in Figure 4.12 through Figure 4.15 were considered to result from the fault arc. However, they can also be considered as a shunt load, shunt reactor, shunt capacitor, and so on, connected at a given point to the system. Various types and their sequence interconnections are covered in Blackburn (1993).

4.11 EXAMPLE: FAULT CALCULATIONS ON A TYPICAL SYSTEM SHOWN IN FIGURE 4.16

The system of Figure 4.16 is the same as that shown in Figure 4.5, but with typical constants for the various parts. These are on the bases indicated, so the first step is to transfer them to a common base, as discussed in Chapter 2. The positive- and negative-sequence networks (negative is the same as positive, except for the omission of the voltage) are shown in Figure 4.17. The conversion to a common base of 100 MVA is shown as necessary.

For a fault at bus G, the right-hand impedances ($j0.18147 + j0.03667 + j0.03 = j0.5481$) are paralleled with the left-hand impedances ($j0.20 + j0.1375 = j0.3375$). Reactance values, rather than impedance values, are used, as is typical when the resistance is relatively small.

$$X_1 = X_2 = \frac{(0.5763) \quad (0.4237)}{0.3375 \times 0.2481} = j0.1430 \text{ pu}. \quad (4.28)$$

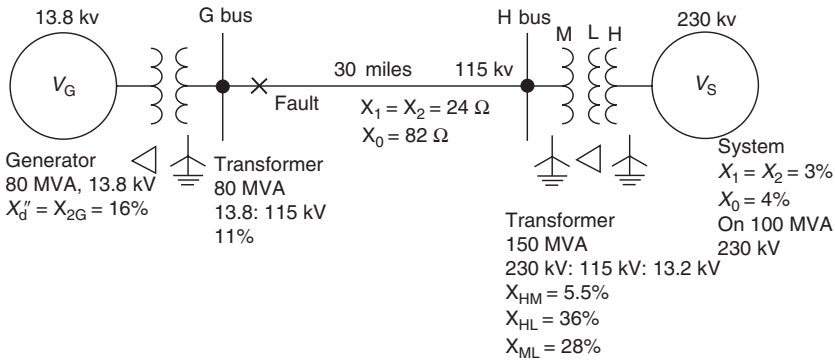

FIGURE 4.16 Power system example for fault calculations.

The division of $0.3375/0.5856 = 0.5763$ and $0.2481/0.5856 = 0.4237$, as shown, provides a partial check, for $0.5763 + 0.4237$ must equal 1.0, which are the distribution factors indicating the per-unit current flow on either side of the fault. These values are added to the network diagram. Thus, for faults at bus G, $X_1 = X_2 = j0.1430$ pu on a 100 MVA base.

The zero-sequence network for Figure 4.16 is shown in Figure 4.18. Again the reactance values are converted to a common 100 MVA base.

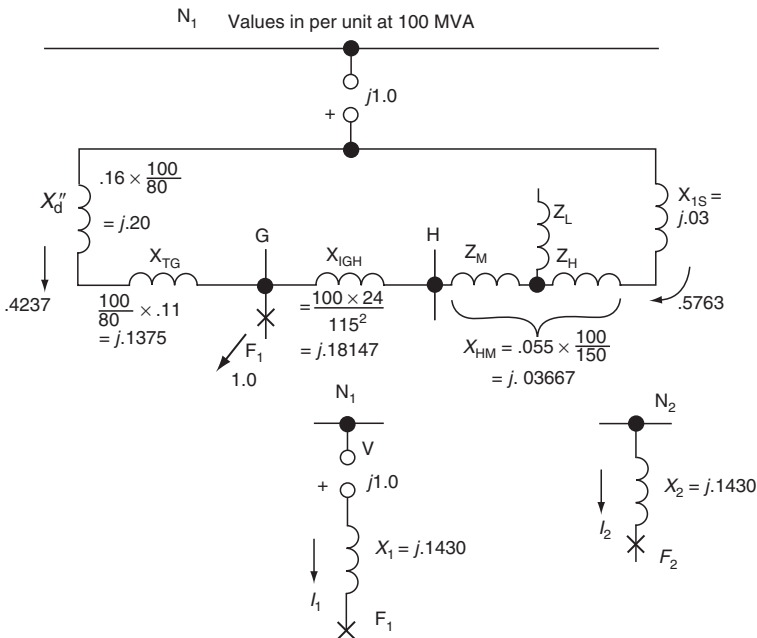

FIGURE 4.17 Positive- and negative-sequence networks and their reduction to a single impedance for a fault at bus G in the power system in Figure 4.16.

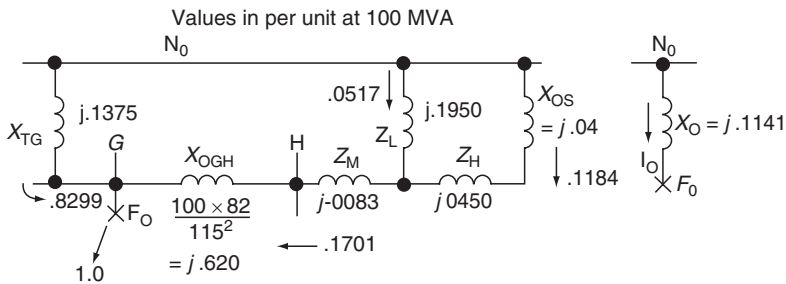

FIGURE 4.18 Zero-sequence network and its reduction to a single impedance for a fault at bus G in the power system in Figure 4.16.

The three-winding bank connections are as indicated in Figure A4.2-3b with $Z_{NH} = Z_{NM} = 0$ because the neutrals are shown as solidly grounded.

The conversions to a common 100 MVA base are shown, except for the three-winding transformer. For this bank,

$$X_{HM} = 0.055 \times \frac{100}{150} = 0.03667 \text{ pu,}$$

$$X_{HL} = 0.360 \times \frac{100}{150} = 0.2400 \text{ pu,}$$

$$X_{ML} = 0.280 \times \frac{100}{150} = 0.18667 \text{ pu,}$$

and from Equation A4.2-13 through Equation A4.2-15,

$$X_H = \frac{1}{2}(0.03667 + 0.2400 - 0.18667) = 0.0450 \text{ pu,}$$

$$X_M = \frac{1}{2}(0.03667 + 0.18667 - 0.2400) = -0.00833 \text{ pu,}$$

$$X_L = \frac{1}{2}(0.2400 + 0.18667 - 0.3667) = 0.1950 \text{ pu.}$$

(4.29)

These are shown in Figure 4.18.

This network is reduced for a fault at bus G by the first paralleling $X_{OS} + Z_H$ with Z_L and then adding Z_M and X_{OGH} :

$$\frac{(0.6964) \quad (0.3036)}{0.1950 \times 0.0850} = j0.0592$$

$$\frac{0.1950 \times 0.0850}{0.280} = j0.0592$$

$$-j0.0083 \quad (Z_M)$$

$$\frac{j0.620}{j0.6709} \quad (X_{OGH}).$$

This is the right-hand branch paralleling with the left-hand branch,

$$X_0 = \frac{(0.8299) \quad (0.1701)}{0.6709 \times 0.1375} = j0.1141 \text{ pu at 100 MVA.} \quad (4.30)$$

The values (0.8299) and (0.1701) add to 1.0 as a check and provide the current distribution on either side of the bus G fault, as shown on the zero-sequence network. The distribution factor 0.1701 for the right side is further divided by $0.6964 \times 0.1701 = 0.1184$ pu in the 230 kV system neutral and $0.3036 \times 0.1701 = 0.0517$ pu in the three-winding transformer H neutral winding. These are shown on the zero-sequence network.

4.11.1 THREE-PHASE FAULT AT BUS G

For this fault,

$$\begin{aligned} I_1 = I_{aF} &= \frac{j1.0}{j0.143} = 6.993 \text{ pu} \\ &= 6.993 \frac{100,000}{\sqrt{3} \times 115} = 3510.8 \text{ A at 115 kV.} \end{aligned} \quad (4.31)$$

The divisions of current from the left (I_{aG}) and right (I_{aH}) are:

$$I_{aG} = 0.4237 \times 6.993 = 2.963 \text{ pu,} \quad (4.32)$$

$$I_{aH} = 0.5763 \times 6.993 = 4.030 \text{ pu.} \quad (4.33)$$

4.11.2 SINGLE-PHASE-TO-GROUND FAULT AT BUS G

For this fault,

$$I_1 = I_2 = I_0 = \frac{j1.0}{j(0.143 + 0.143 + 0.1141)} = 2.50 \text{ pu,} \quad (4.34)$$

$$\begin{aligned} I_{aF} &= 3 \times 2.5 = 7.5 \text{ pu at 100 MVA,} \\ &= 7.5 \times \frac{100,000}{\sqrt{3} \times 115} = 3764.4 \text{ A at 115 kV.} \end{aligned} \quad (4.35)$$

Normally, the $3I_0$ currents are documented in the system, for these are used to operate the ground relays. As an aid to understanding these are illustrated in [Figure 4.19](#) along with the phase currents. [Equation 4.5](#) through [Equation 4.7](#) provide the three-phase currents. Because $X_1 = X_2$, such that $I_1 = I_2$, these reduce to $I_b = I_c = -I_1 + I_0$ for the phase b and c currents, since $a + a^2 = -1$. The currents shown are determined by adding $I_1 + I_2 + I_0$ for I_a , $-I_1 + I_0$ for I_b , and I_c and $3I_0$ for the neutral currents.

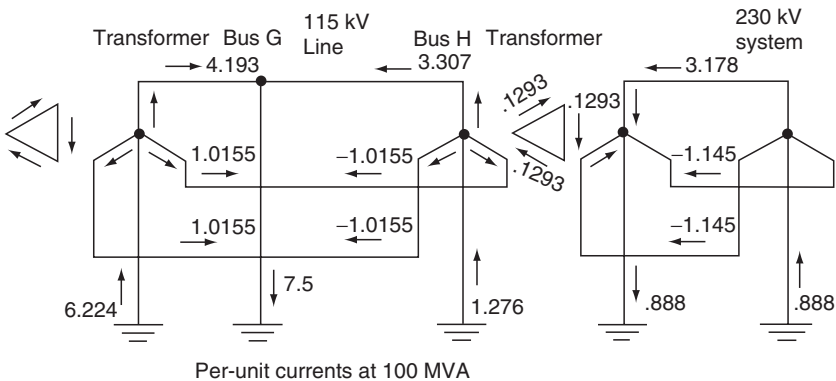

FIGURE 4.19 Phase and $3I_0$ current distribution for a single-phase-to-ground fault at bus G in Figure 4.16.

In the 115 kV system the sum of the two neutral currents is equal and opposite to the current in the fault. In the 230 kV system the current up the neutral equals the current down the other neutral.

The calculations assumed no load; accordingly, pre-fault, all currents in the system were zero. With the fault involving only phase a , it will be observed that current flows in the b and c phases. This is because the distribution factors in the zero-sequence network are different from the positive- and negative-sequence distribution factors. On a radial system where positive-, negative-, and zero-sequence currents flow only from one source and in the same direction, the distribution factors in all three networks will be 1.0, in spite of the zero-sequence impedances. Then $I_b = I_c = -I_1 + I_0$ becomes zero, and fault current flows only in the faulted phase. In this type $I_a = 3I_0$ throughout the system for a single-phase-to-ground fault.

4.12 EXAMPLE: FAULT CALCULATION FOR AUTOTRANSFORMERS

Autotransformers have become quite common in recent years. They provide some different and interesting problems. Consider a typical autotransformer in a system, as shown in Figure 4.20, and assume that a single-phase-to-ground fault occurs at the H or 345 kV system values that are given based on this consideration. For the autotransformer, the equivalent network is as in Figure A4.2-3d, with values as follows: On a 100 MVA base,

$$\begin{aligned}
 X_{HM} &= 8 \times \frac{100}{150} = 5.333\% = 0.05333 \text{ pu,} \\
 X_{HL} &= 34 \times \frac{100}{150} = 68\% = 0.68 \text{ pu,} \\
 X_{ML} &= 21.6 \times \frac{100}{40} = 54\% = 0.54 \text{ pu,}
 \end{aligned}
 \tag{4.36}$$

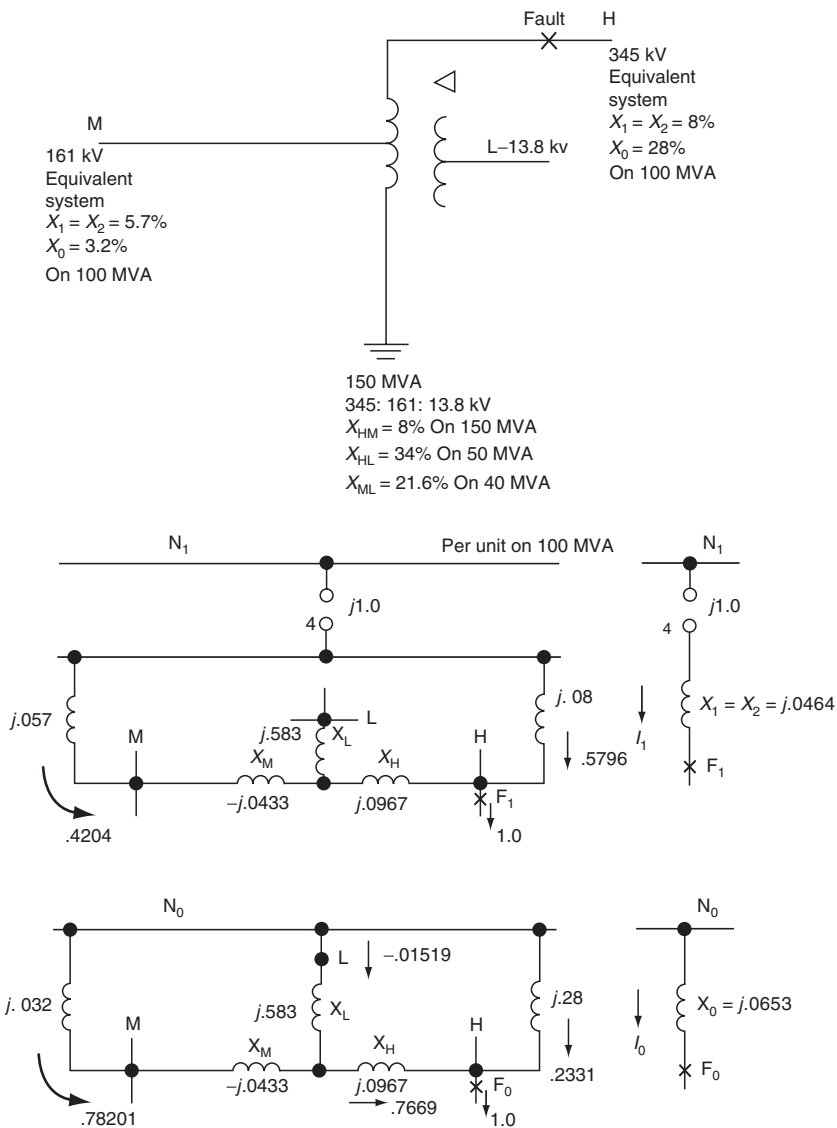

FIGURE 4.20 Example of fault calculation for an autotransformer.

and from Equation A4.2-13 through Equation A4.2-15,

$$\begin{aligned}
 X_H &= \frac{1}{2}(0.0533 + 0.68 - 0.54) = 0.09667 \text{ pu,} \\
 X_M &= \frac{1}{2}(0.0533 + 0.54 - 0.68) = -0.04334 \text{ pu,} \\
 X_L &= \frac{1}{2}(0.68 + 0.54 - 0.0533) = 0.58334 \text{ pu.}
 \end{aligned}
 \tag{4.37}$$

These values are shown in the sequence diagrams in [Figure 4.20](#). In the positive- (and negative)-sequence networks for a fault at H,

$$X_1 = X_2 \frac{(0.5796) (0.4204)}{(0.0533 + 0.057)(0.08)} = j0.04637 \text{ pu.} \quad (4.38)$$

The zero-sequence network reduces as follows: first paralleling the left side,

$$\begin{aligned} &= \frac{(0.032 - 0.0433)(0.5833)}{0.032 - 0.0433 + 0.5833} = \frac{(-0.0198)(1.0198)}{0.5720} \\ &= -0.01156 \text{ pu} \\ X_0 &= \frac{(-0.01156 + 0.09667)(0.28)}{0.08511 + 0.28} = \frac{(0.2331)(0.7669)}{0.36511} \\ &= j0.06527 \text{ pu.} \end{aligned} \quad (4.39)$$

The current distribution factor through the X_M path is $0.7669 \times 1.0198 = 0.78207$, and through the X_L path is $0.7669 \times -0.0198 = -0.01519$. These current distributions are shown on the network.

4.12.1 SINGLE-PHASE-TO-GROUND FAULT AT H CALCULATION

$$\begin{aligned} I_1 = I_2 = I_0 &= \frac{j1.0}{j(0.0464 + 0.0464 + 0.0653)} = \frac{1.0}{0.1580} \\ &= 6.3287 \text{ pu} \\ &= 6.3287 \times \frac{100,000}{\sqrt{3} \times 345} = 1059.1 \text{ A at 345 kV} \end{aligned} \quad (4.40)$$

$$\begin{aligned} I_{aF} &= 3I_0 = 3 \times 6.3287 = 18.986 \text{ pu} \\ &= 3 \times 1059.1 = 3177.29 \text{ A at 345 kV.} \end{aligned} \quad (4.41)$$

It is recommended that amperes, rather than per unit, may be used for fault current distribution, particularly in the neutral and common windings. The autotransformer is unique in that it is both a transformer and a direct electrical connection. Thus, amperes at the medium-voltage base I_M are combined directly with amperes at the high-voltage base I_H for the common winding current I or for the high-side fault,

$$I = I_H(\text{in amperes at kV}_H) - I_M(\text{in amperes at kV}_M). \quad (4.42)$$

For the current in the grounded neutral,

$$3I_0 = 3I_{0H} \text{ (in amperes at kV}_H\text{)} - 3I_{0M} \text{ (in amperes at kV}_M\text{)}. \quad (4.43)$$

Both of the foregoing currents are assumed to flow up the neutral and to the M junction point.

Correspondingly, for a fault on the M or medium-voltage system, the current flowing up the grounded neutral is

$$3I_0 = 3I_{0M} \text{ (in amperes at kV}_M\text{)} - 3I_{0H} \text{ (in amperes at kV}_H\text{)}. \quad (4.44)$$

Thus, these currents in the common winding and neutral are a mixture of high- and medium-voltage currents; therefore, there is no base to which they can be referred. This makes per unit difficult, as it must have a base. When, or if, per unit must be used, a fictional base can be devised based on the ratios of the transformer parts. This is quite complex. Because it is the fundamental base, amperes are easy to handle and they will be used in the following.

The sequence, phase *a*, and neutral currents are documented in Figure 4.21 for the example in Figure 4.20. There will be current flowing in phases *b* and *c* because the current distribution factors are different in the positive- and zero-sequence networks. These are not shown, for they are of little importance in protection.

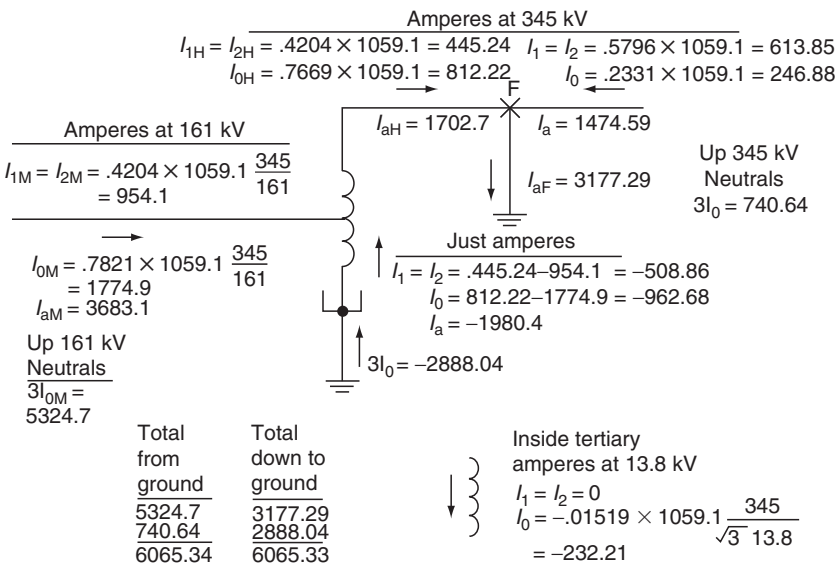
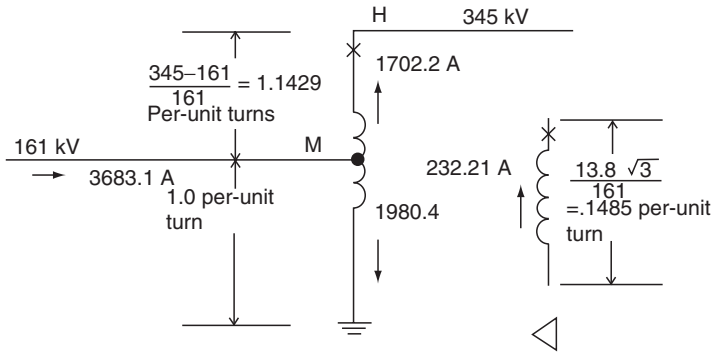

FIGURE 4.21 Fault current distribution for the autotransformer in Figure 4.20.



$$\begin{aligned}
 &\text{Ampere-turns up} = \text{Ampere-turns down} \\
 &1702.7 \times 1.1429 + 232.21 \times .1485 = 1980.4 \times 1.0 \\
 &1946.02 + 34.48 = 1980.4 \\
 &1980.5 = 1980.4 \text{ Check.}
 \end{aligned}$$

FIGURE 4.22 Ampere-turn check to confirm or establish the direction of current flow in the tertiary.

The example indicates that current flows in the downward direction of the neutral sequence of the autotransformer instead of the upward direction, as might be expected. In addition, in this example, the current in the delta has reversed, because the negative branch of the transformer-equivalent circuit is larger than the very solidly grounded 161 kV connected system. Both these effects influence the protection. This is discussed further in [Chapter 12](#).

There can be a question about the direction of current in the tertiary. This can be checked by ampere turns, as shown in Figure 4.22. Arbitrarily, one per-unit turn was assumed for the 161 kV winding and the others were derived. Any convenient winding or group could be used for the base.

4.13 EXAMPLE: OPEN-PHASE CONDUCTOR

A blown fuse or broken conductor that opens one of the three phases represents an unbalance series that is dealt more in detail in Blackburn (1993). As an example, consider phase *a* open on the 34.5 kV line at bus H that is given in [Figure 4.23](#). All constants are in per unit on a 30 MVA base.

The three sequence networks are shown in [Figure 4.24](#). With no load, opening any phase makes no difference in the current flow because it is already zero. Constantly, in these series unbalances, it is necessary to consider load; therefore, the 30 MVA, 90%, is as shown. With induction motor loads, the negative-sequence load impedance is less than the positive-sequence impedance. This is covered in [Chapter 11](#).

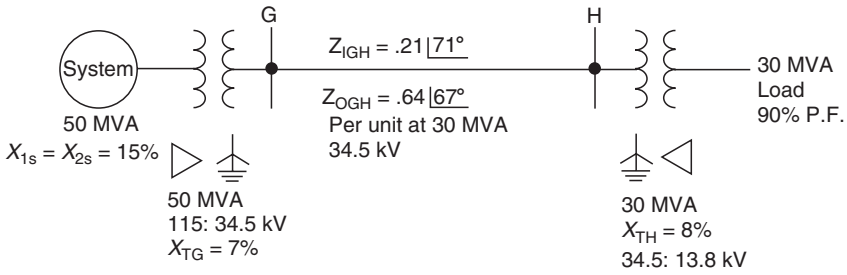

FIGURE 4.23 Example for series unbalance calculations.

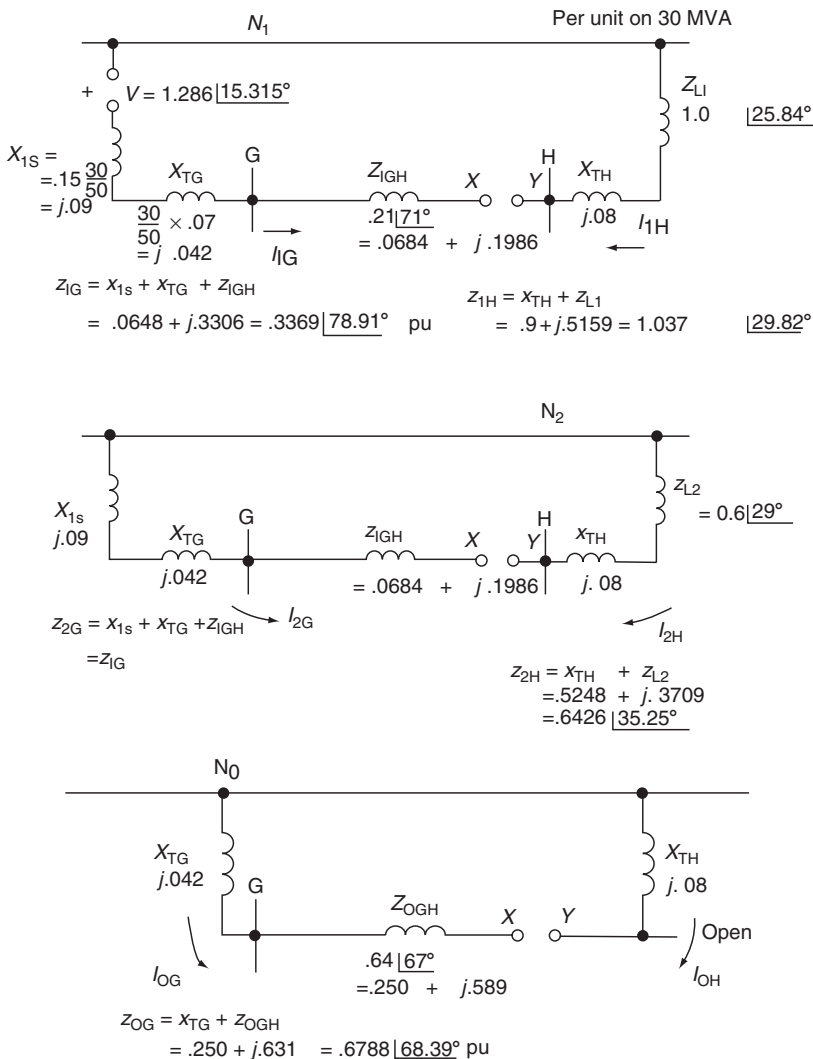

FIGURE 4.24 The three sequence networks for the system in Figure 4.23.

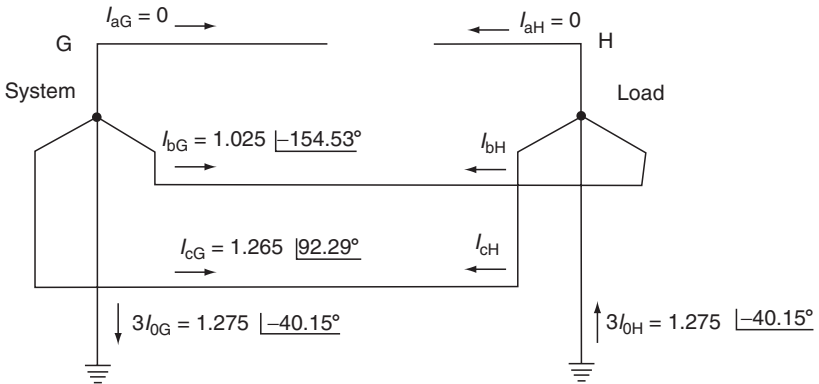

FIGURE 4.25 Per-unit current distribution for an open conductor in the power system in Figure 4.23 (per unit at 30 MVA where 1 pu = 502 A at 34.5 kV).

If we assume the voltage at the load to be 1.00° pu, then the voltage at the generator will be $1.286 \angle 15.315^\circ$. Phase a open is represented by connecting the three-sequence X points together and the three-sequence Y points together. This connects the total zero-sequence impedances in parallel with the total negative-sequence impedances across the open X – Y of the positive-sequence network. From these data, I_1 , I_2 , and I_0 can be easily calculated.

The resulting currents flowing in the system are shown in Figure 4.25 and are in the order of normal load currents. Thus, it is difficult to locate and provide protection for these faults.

4.14 EXAMPLE: OPEN PHASE FALLING TO GROUND ON ONE SIDE

In the system shown in Figure 4.23, the phase a conductor on the line at bus H opens and falls to ground value on the bus H side. The sequence networks are the same as those indicated in Figure 4.24, but are interconnected, as can be noted in Figure 4.26. These are simultaneous faults: a series open-phase fault and a phase-to-ground fault. Thus, three ideal or perfect transformers are used for isolation of the open-phase X – Y interconnection from three networks in series for the ground fault. Because these transformers have no leakage or exciting impedances, the voltage drop across them cannot be expressed by the current in their windings. The currents I_1 , I_2 , and I_0 can be determined by solving various voltage drop equations around the networks. The resulting fault currents are shown in Figure 4.27. In this instance, it is possible to obtain currents by neglecting the load. These are shown in parentheses in Figure 4.27.

The other possibility is that the open conductor falls to ground value on the line side. Here, the three ideal transformers are moved to the left or X side of the

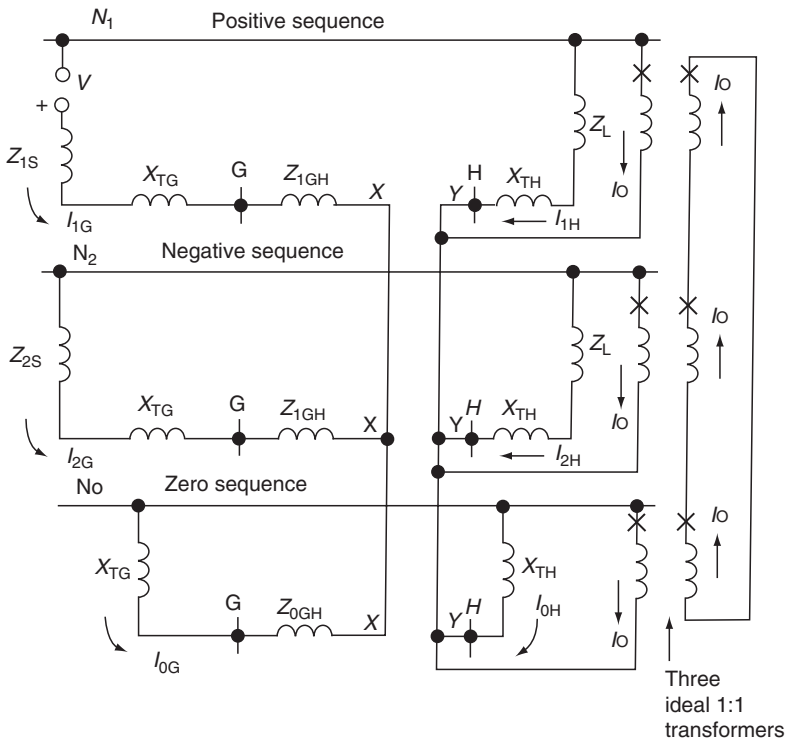
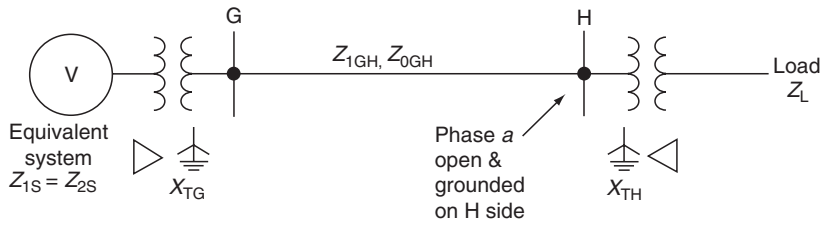

FIGURE 4.26 Example of the sequence network interconnections for phase *a* open and grounded at bus H (broken conductor has fallen to ground value).

three-sequence networks: there is now no option—load must be considered. The fault currents are shown in [Figure 4.28](#). Note that, as in the open phase (see [Figure 4.25](#)), the currents are still quite low, not higher than load currents.

4.15 SERIES AND SIMULTANEOUS UNBALANCES

Series and simultaneous unbalances certainly occur in power systems. One type is a blown fuse or open (broken) phase conductor. The broken conductor can contact the ground making a simultaneous unbalance. Several instances of these are covered with examples in Blackburn (1993).

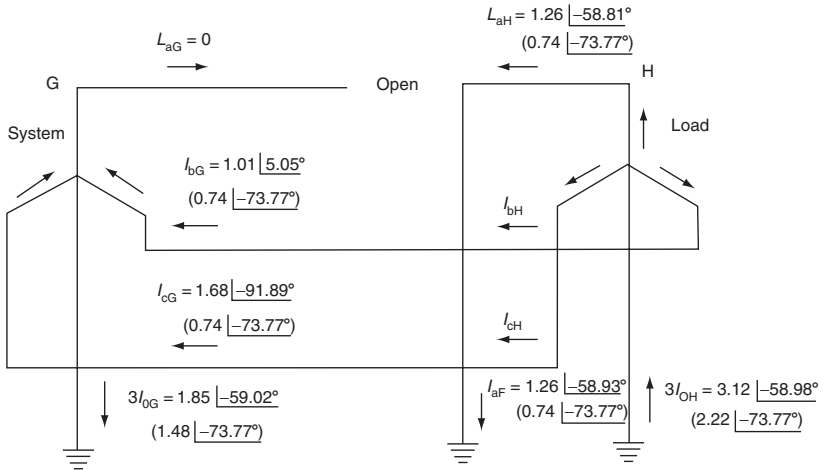

FIGURE 4.27 Per-unit current distribution for a broken conductor at bus H that falls to ground value on the bus H side in the power system in Figure 4.23. Top values are seen with a 30 MVA load. Values in parentheses are with load neglected (no load). Per unit is at 30 MVA where $1 \text{ pu} = 502 \text{ A}$ at 34.5 kV.

4.16 OVERVIEW

Faults and the sequence quantities can be visualized and perhaps be better understood by an overall view in contrast to the specific representations and calculations. Accordingly, several overviews are presented next.

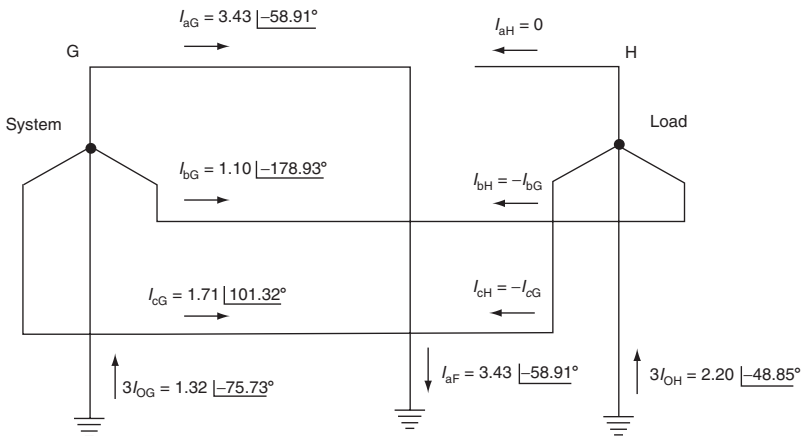

FIGURE 4.28 Per-unit current distribution for a broken conductor at bus H that falls to ground value on the line side in the power system in Figure 4.29. Per unit is at 30 MVA when $1 \text{ pu} = 502 \text{ A}$ at 34.5 kV.

4.16.1 VOLTAGE AND CURRENT PHASORS FOR SHUNT FAULTS

The first overview is a review of shunt faults, which are the common types experienced on a power system. These are illustrated in Figure 4.29, with Figure 4.29a showing the normal balanced voltage and load current phasors. Load is slightly lagging, normally from unit power factor to about a 30° lag. With capacitors at light load, the currents may slightly be direct.

When faults occur, the internal voltage of the generators does not change; that is true unless the fault is left unattended for long, and the voltage regulators attempt to increase the terminal voltage of the fault-reduced machine.

A three-phase fault (see Figure 4.29a) reduces all three voltages and causes a large increase and higher lagging by the system, and usually varies from about a 30° to 45° lag, and sometimes nearly a 90° lag (see Figure 4.29b).

The single-phase-to-ground fault (see Figure 4.29c) is the most common one. The faulted-phase voltage collapses, and its current increases, as shown. Load current is neglected, for it is usually relatively small, and $I_b = I_c = 0$. As has been

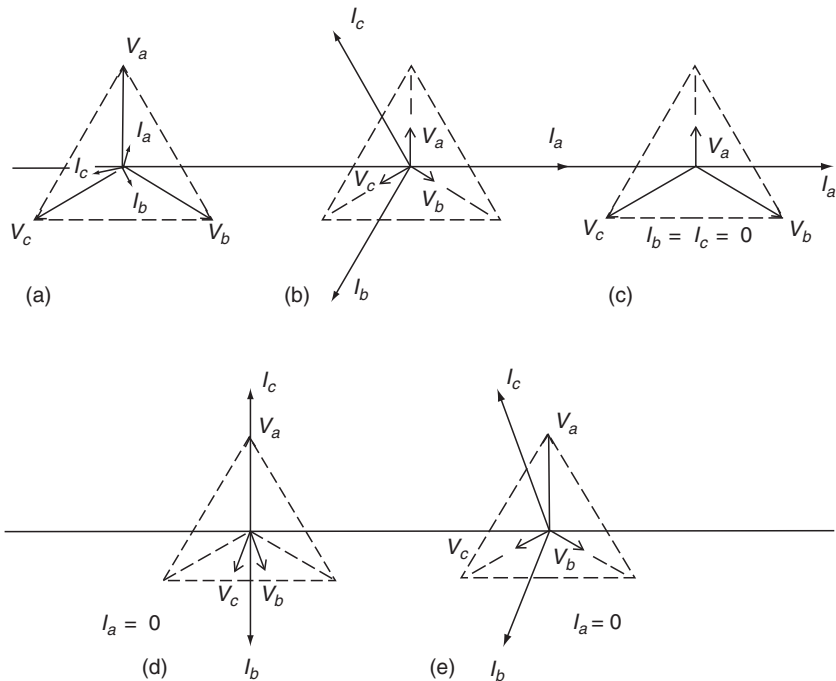

FIGURE 4.29 Typical current and voltage phasors for common shunt faults: The fault currents are shown at 90° lagging or for a power system where $Z = X$. During faults the load is neglected. (a) Normal balanced system; (b) three-phase faults; (c) phase-to-ground a -Gnd faults; (d) phase-to-phase bc faults; (e) two-phase-to-ground bc -Gnd faults.

indicated earlier, fault current flows in the unfaulted phases on loop systems in which the distribution factors for the three sequence networks are different. Once again the fault current lags normally. It is shown at 90° in [Figure 4.29c](#).

The phase-to-phase fault is seen in [Figure 4.29d](#). Neglecting the load, for a *b*-to-*c* phase fault, V_a is normal, $I_a = 0$. V_b , and V_c collapse from their normal positions to vertical phasors at a solid fault point where $V_{bc} = 0$. I_b and I_c are normally equal and opposite and lagging is 90° , as shown in [Figure 4.29c](#).

The two-phase-to-ground fault (see [Figure 4.29c](#)) results in the faulted phase voltages collapsing along their normal position until, for a solid fault, they are zero. Thus, at the fault, $V_b = V_c = 0$, which is not true for the phase-to-phase fault (see [Figure 4.29d](#)). I_b and I_c will be in the general area, as shown. An increasing amount of zero-sequence current will cause I_b and I_c to swing closer to each other; contrarily, a low zero-sequence current component will result in the phasors approaching the phase-to-phase fault in [Figure 4.29d](#). This can be seen from the sequence network connections of [Figure 4.15](#). For a phase-to-phase fault, if Z_0 becomes infinite (essentially ungrounded system), the interconnection becomes as indicated in [Figure 4.14](#). On the other hand, for a very solidly grounded system where Z_0 approached zero relatively, the negative network becomes shorted, and this fault becomes similar to the three-phase fault as shown in [Figure 4.12](#).

Total fault current in per unit

Based on $V = j1$ pu; $Z_1 = Z_2 = j1$ pu; and $Z_0 = jX_1$ pu

$$I_{30} = 1.0$$

$$I_{00} = 0.866^a$$

Fault	X_0 pu: 0.1	0.5	1.0	2.0	10.0
10 Gnd	1.43	1.2	1.0	0.75	0.25
00 Gnd	1.52	1.15	1.0	0.92	0.87
$3I_{00}$ Gnd	-2.5	-1.5	-1.0	-0.6	-0.143
Angle of I_{b00} Gnd	-145.29°	-130.89°	-120°	-109.11°	94.69°
Angle of I_{c00} Gnd	145.29°	130.89°	120°	109.11°	94.69°

For the phase-to-phase fault:

$$I_1 = -I_2 = 1/1 + 1 = 0.5. I_b = a^2 I_1 + a I_2 = (a^2 - a) I_1 = -j\sqrt{3}(0.5) = -j0.866.$$

In some parts of a loop network it is possible for the zero-sequence current to flow opposite the positive- and negative-sequence currents. In this area I_c may lag the V_c phasor, rather than lead it as shown, correspondingly with I_b leading the position, as shown.

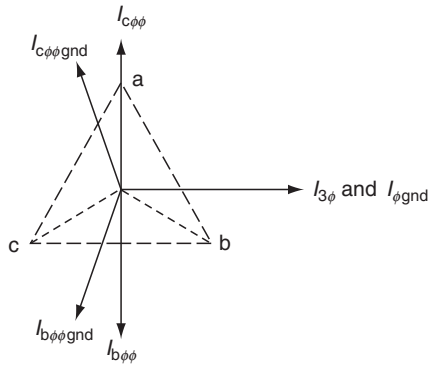

FIGURE 4.30 Comparison of solid shunt-type faults.

These trends are further amplified by Figure 4.30, which compares the various solid shunt faults. The effect of the zero sequence for ground faults is illustrated by various values of X_0 reactances relative to $X_1 = X_2$. As has been indicated, the zero-sequence network is always different from the positive- and negative-sequence networks. However, X_0 can be approximately equal to X_1, X_2 for secondary bus faults on distribution feeders connected to large power systems. In these cases, the systems X_1, X_2 are very small relative to the primary delta-secondary wye-grounded distribution transformer. Thus, the case of $X_1 = X_2 = X_0$ is quite practicable.

4.16.2 SYSTEM VOLTAGE PROFILES DURING FAULTS

The trends of the sequence voltages for the various faults in Figure 4.29 are illustrated in Figure 4.31. Only the phase a sequence voltages are shown for an ideal case where $Z_1 = Z_2 = Z_0$. This makes the presentation less complex and does not affect the trends shown.

With the common assumption of no load, the system voltage is equal throughout the system, as indicated by the dashed lines. When a solid three-phase fault occurs, the voltage at the fault point becomes zero, but as indicated earlier, does not change in the source until the regulators act to change the generator fields. Meanwhile, the fault should have been cleared by protective relays. Thus, the voltage profile is as shown in Figure 4.31a.

For phase-to-phase faults (see Figure 4.31b), the positive-sequence voltage drops to half value ($Z_1 = Z_2$). This unbalance fault is the source of negative sequence and the V_2 drops, which are zero in the generators, are as shown.

For two-phase-to-ground faults (see Figure 4.31c) with $Z_1 = Z_2 = Z_0$, the positive-sequence voltage at the fault drops to one-third of V_1 . The fault at this moment generates both negative and zero sequences that flow through the system, producing voltage drops as shown. The voltage V_2

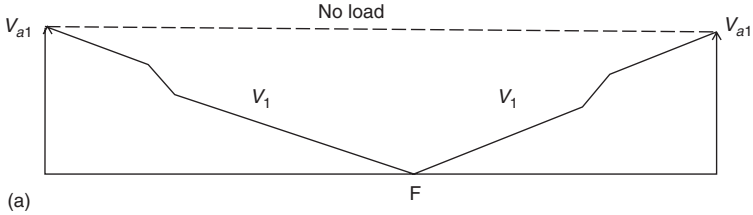
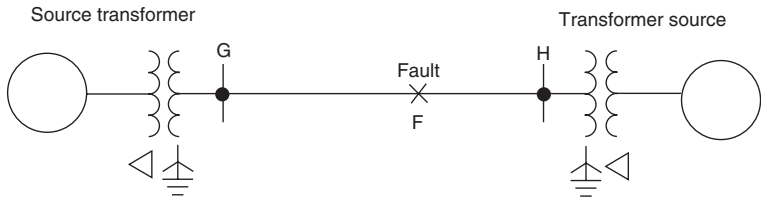

(a)

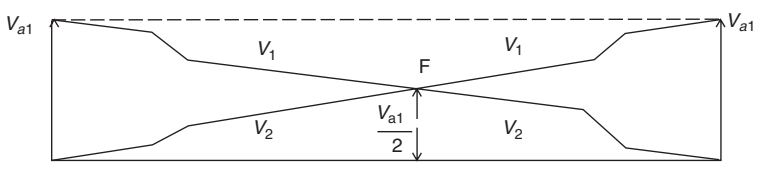

(b)

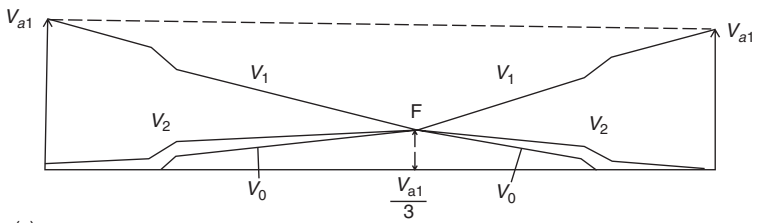

(c)

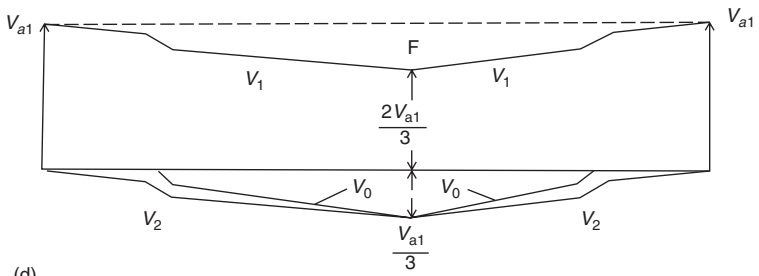

(d)

FIGURE 4.31 System sequence voltage profiles during shunt faults: (a) three-phase faults; (b) phase-to-phase faults; (c) two-phase-to-ground faults; (d) phase-to-ground faults.

becomes zero in the generators, whereas V_0 is zero at the grounded transformer neutral point.

The fault voltage for a phase-*a*-to-ground solid fault is zero and as documented in Figure 4.31d, the sum of the positive-, negative-, and zero-voltage components at the fault add to zero. Thus, the positive-sequence voltage drops to $2/3V_1$ when $Z_1 = Z_2 = Z_0$ at the fault point, where $-1/3V_2$ and $-1/3V_0$ are generated. Subsequently, they drop to zero in the generator or source for the negative sequence and to zero at the grounded transformer bank neutral.

The fundamental concept illustrated in Figure 4.31 is that positive-sequence voltage is always maximum at the generators and minimum at the fault. The negative- and zero-sequence voltages are always maximum at the fault and minimum at the generator or grounded neutral.

It is common to refer to the grounded-wye-delta or similar banks as “ground sources.” This is really a misnomer, as the source of zero sequence is the unbalance, the ground fault. However, thus designating these transformers as ground sources is practical, since, by convention ground ($3I_0$) current flows up the grounded neutral, through the system, and down the fault into ground.

4.16.3 UNBALANCED CURRENTS IN THE UNFAULTED PHASES FOR PHASE-TO-GROUND FAULTS IN LOOP SYSTEMS

A typical loop system is illustrated in Figure 4.32. A phase-*a*-to-ground fault occurs on the bus at station E, as shown in Figure 4.33. The fault calculation was made at no-load; therefore, the current before the fault in all three phases was zero in all parts of the system. However, fault current is shown flowing in all three phases. This is because the current distribution factors in the loop are different in the sequence networks. With X_0 not equal

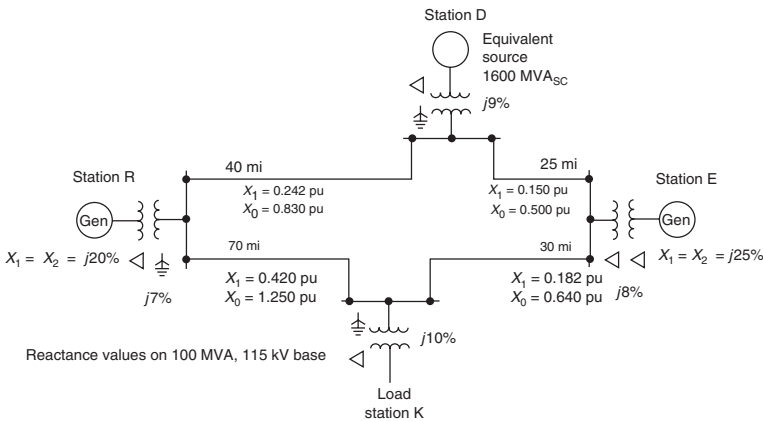

FIGURE 4.32 A typical loop-type power system.

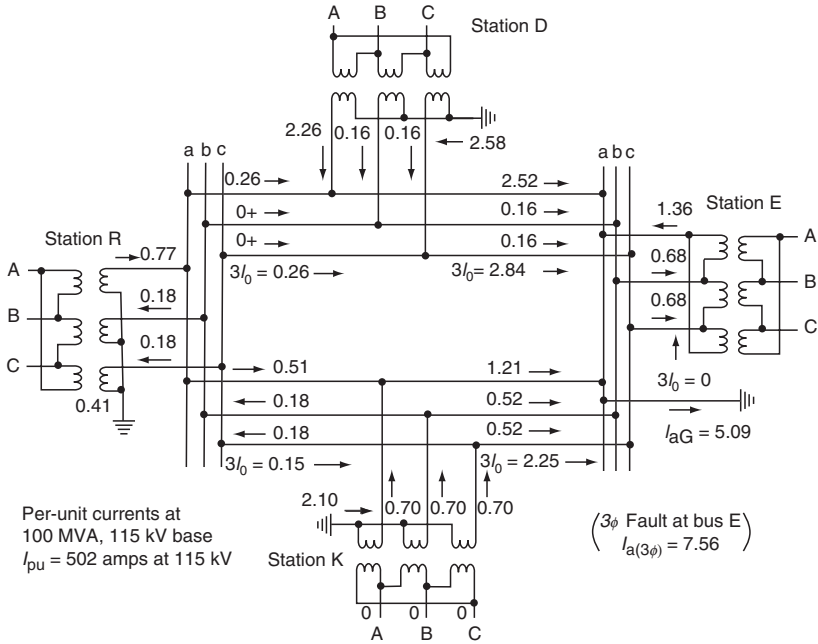

FIGURE 4.33 Currents for a phase-*a*-to-ground fault at station E bus in Figure 4.32.

to $X_1 = X_2$, $I_b = a^2 I_1 + a I_2 + I_0 = -I_1 + I_0$. Likewise, $I_c = -I_1 + I_0$. These are the currents flowing in phases *b* and *c* as shown in Figure 4.33.

This will always occur in any system or part of a system in which there are positive-sequence sources or zero-sequence sources at both ends. In ground fault studies, $3I_0$ values should be recorded because the ground relays are operated by $3I_0$, not the phase-fault currents, which can be quite different, as seen in Figure 4.33. Thus, there is little or no use in recording the phase values. These differences make fuse applications on loop systems quite difficult, because the fuse is operated on phase current, but the ground relays are on $3I_0$ currents.

For radial lines or feeders (positive-sequence source and a wye-grounded transformer at the same end, and no source or grounded transformer at the other end) I_b and I_c will be zero for all phase-*a*-to-ground faults. With the same phase and $3I_0$ ground currents, it is easier to coordinate ground relays and fuses.

4.16.4 VOLTAGE AND CURRENT FAULT PHASORS FOR ALL COMBINATIONS OF THE DIFFERENT FAULTS

The sequence phasors from a different perspective are presented in Figure 4.34 and Figure 4.35. The voltages and currents generated by the sources can

Fault type	Positive sequence	Negative sequence	Zero sequence	Fault voltages
<i>a,b,c</i>				Zero at fault
<i>a,b</i>				
<i>b,c</i>				
<i>c,a</i>				
<i>a,b,G</i>				
<i>b,c,G</i>				
<i>c,a,G</i>				
<i>a,G</i>				
<i>b,G</i>				
<i>c,G</i>				

FIGURE 4.34 Sequence voltages and the voltage at the fault point for the various fault types. Solid faults with $Z_1 = Z_2 = Z_0$ for simplicity. Magnitudes are not to scale.

Fault type	Positive sequence	Negative sequence	Zero sequence	Fault currents
a,b,c				
a,b				
b,c				
c,a				
a,b,G				
b,c,G				
c,a,G				
a,G				
b,G				
c,G				

FIGURE 4.35 Sequence currents and the fault current for the various fault types: Solid faults with $Z_1 = Z_2 = Z_0$ for simplicity. Magnitudes are not to scale.

only be positive sequence by design, and nothing else. Yet the unbalanced faults require unbalanced quantities. How can this difference be resolved to satisfy both requirements: balanced quantities by the generators and unbalanced quantities at the faults? The resolution can be considered as the function of the negative-sequence quantities and for ground faults the zero-sequence quantities. This can be seen as indicated in Figure 4.34 and Figure 4.35. Considering the voltages as shown in Figure 4.34, the voltage developed by the source or generator is the same for all faults. For three-phase faults no transition help is required because these faults are symmetrical; hence, there are no negative or zero sequences. For the phase-to-phase faults, negative sequence appears to provide the transition. Note that for the several combinations, ab , bc , and ca phases, the negative sequence is in different positions to provide the transition. The key is that for, say, ab fault, phase c will be essentially normal, so V_{c1} and V_{c2} are basically in phase to provide this normal voltage. Correspondingly, for a bc fault, V_{a1} and V_{a2} are essentially in phase, and so on.

The two-phase-to-ground faults are similar; for ab -G faults, the uninvolved phase c quantities V_{c1} , V_{c2} , and V_{c0} combine to provide the uncollapsed phase c voltage. In the figure, these are shown in phase and at half magnitude. In actual cases, there will be slight variations because the sequence impedances do not have the same magnitude or phase angle.

For single-phase- a -to-ground faults, the negative (V_{z2})- and zero (V_{a0})-sequence voltages add to cancel the positive-sequence V_{a1} , which will be zero at a solid fault. Correspondingly, for a phase b fault, V_{b2} and V_{b0} oppose V_{b1} , and similarly for the phase c fault.

The same concept is applied to the sequence currents, as shown in Figure 4.35. The positive-sequence currents are shown in the same for all faults and for 90° lag (X -only system) relative to the voltages in Figure 4.34. These will vary depending on the system constants, but the concepts illustrated are valid. Moreover, for three-phase faults, no transition help is required; hence, there is no negative- or zero-sequence involvement.

For phase-to-phase faults negative sequence provided the necessary transition, with the unfaulted phase-sequence currents in opposition to provide either a zero or a low current. Thus, for the ab fault, I_{c1} and I_{c2} are in opposition.

Similarly for two-phase-to-ground faults; for an ab -G fault, I_{c2} and I_{c0} tend to cancel I_{c1} and so on. For single-phase-to-ground faults the faulted phase components tend to add to provide a large fault current, because $I_{a1} + I_{a2} + I_{a0} = I_a$.

4.17 SUMMARY

A question often asked is “Are the sequence quantities real or only useful in mathematical concepts?” This has been debated for years, and in a sense they

are both accepted. Yes, they are real; positive sequence certainly because it is generated, sold, and consumed; zero sequence because it flows in the neutral, ground, and deltas; and negative sequence, for example, cannot be measured directly by an ammeter or voltmeter. Networks are available and commonly used in protection to measure V_2 and I_2 , but these are designed to solve the basic equations for those quantities.

In either event, analyses of symmetrical components is an extremely valuable and powerful tool. Protection engineers automatically tend to think in its terms when evaluating and solving unbalanced situations in the power system.

It is important to always remember that any sequence quantity cannot exist in only one phase; this is a three-phase concept. If any sequence is in one phase, it must be in all three phases, according to the fundamental definitions of [Equation 4.2](#) through [Equation 4.4](#).

BIBLIOGRAPHY

- Anderson, P.M., *Analysis of Faulted Power Systems*, Iowa State University Press, Ames, IA, 1973.
- ANSI/IEEE Standard C37.5, Guide for Calculation of Fault Currents for Application of AC High Voltage Circuit Breakers Rated on a Total Current Basis, IEEE Service Center.
- Blackburn, J.L., *Symmetrical Components for Power Systems Engineering*, Marcel Dekker, New York, 1993.
- Calabrese, G.O., *Symmetrical Components Applied to Electric Power Networks*, Ronald Press, New York, 1959.
- Clarke, E., *Circuit Analysis of AC Power Systems*, Vols. 1 and 2, and General Electric, Schenectady NY, 1943, 1950.
- Harder, E.L., Sequence network connections for unbalanced load and fault conditions, *Electr. J. Dec.* 1937, pp. 481–188.
- Standard 141-1993, IEEE Recommended Practice for Electric Power Distribution for Industrial plants, IEEE Service Center.
- Wagner, C.F. and Evans, R.D., *Symmetrical Components*, McGraw-Hill, 1933 (available in reprint from R.E. Krieger Publishing, Melbourne, FL, 1982).

Appendix 4.1

Short-Circuit MVA and Equivalent Impedance

Quite often short-circuit MVA data are supplied for three-phase and single-phase-to-ground faults at various buses or interconnection points in a power system. The derivation for this and conversion into system impedances are as follows:

THREE-PHASE FAULTS

$$\text{MVA}_{\text{SC}} = 3\phi \text{ fault-short-circuit MVA} = \frac{\sqrt{3}I_{3\phi}\text{kV}}{1000}, \quad (\text{A4.1-1})$$

where $I_{3\phi}$ is the total three-phase fault current in amperes and kV is the system line-to-line voltage in kilovolts. From this,

$$I_{3\phi} = \frac{1000 \text{ MVA}_{\text{SC}}}{\sqrt{3}\text{kV}}, \quad (\text{A4.1-2})$$

$$Z_{\Omega} = \frac{V_{\text{LN}}}{I_{3\phi}} = \frac{1000 \text{ kV}}{\sqrt{3}I_{3\phi}} = \frac{\text{kV}^2}{\text{MVA}_{\text{SC}}}. \quad (\text{A4.1-3})$$

Substituting Equation 2.15, which is

$$Z_{\text{pu}} = \frac{\text{MVA}_{\text{base}}Z_{\Omega}}{\text{kV}^2}, \quad (2.15)$$

the positive-sequence impedance to the fault location is

$$Z_1 = \frac{\text{MVA}_{\text{base}}}{\text{MVA}_{\text{SC}}} \text{pu}, \quad (\text{A4.1-4})$$

$Z_1 = Z_2$ for all practical cases. Z_1 can be assumed to be X_1 unless X/R data are provided to determine an angle.

SINGLE-PHASE-TO-GROUND FAULTS

$$\frac{\text{MVA}_{\phi\text{GSC}=\phi\text{G fault-short-circuit MVA}}}{1000} = \frac{\sqrt{3}I_{\phi\text{G}}\text{kV}}{1000}, \quad (\text{A4.1-5})$$

where $I_{\phi\text{G}}$ is the total single-line-to-ground fault current in amperes and kV is the system line-to-line voltage in kilovolts.

$$I_{\phi\text{G}} = \frac{1000 \text{ MVA}_{\phi\text{GSC}}}{\sqrt{3}\text{kV}}. \quad (\text{A4.1-6})$$

However,

$$I_{\phi\text{G}} = I_1 + I_2 + I_0 = \frac{3V_{\text{LN}}}{Z_1 + Z_2 + Z_0} = \frac{3V_{\text{LN}}}{Z_g}, \quad (\text{A4.1-7})$$

where $Z_g = Z_1 + Z_2 + Z_0$. From [Equation A4.1-3](#) and Equation A4.1-7,

$$Z_g = \frac{3\text{kV}^2}{\text{MVA}_{\phi\text{GSC}}}, \quad (\text{A4.1-8})$$

$$Z_g = \frac{3\text{MVA}_{\text{base}}}{\text{MVA}_{\phi\text{GSC}}} \text{ pu}. \quad (\text{A4.1-9})$$

Therefore, $Z_0 = Z_g - Z_1 - Z_2$, or in most practical cases, $X_0 = X_g - X_1 - X_2$ because the resistance is usually small in relation to the reactance.

Example

A short-circuit study indicates that at bus X in the 69 kV system,

$$\text{MVA}_{\text{SC}} = 594 \text{ MVA}$$

$$\text{MVA}_{\phi\text{GSC}} = 631 \text{ MVA}$$

on a 100 MVA base.

Thus, the total reactance to the fault is

$$X_1 = X_2 = \frac{100}{594} = 0.1684 \text{ pu}$$

$$X_g = \frac{300}{631} = 0.4754 \text{ pu},$$

$X_0 = 0.4754 - 0.1684 - 0.1684 = 0.1386 \text{ pu}$, all values on a 100 MVA 69 kV base.

Appendix 4.2

Impedance and Sequence Connections for Transformer Banks

TWO-WINDING TRANSFORMER BANKS

Typical banks are shown in [Figure A4.2-1](#). H is the high-voltage winding and L the low-voltage winding. These designations can be interchanged as required. Z_T is the transformer leakage impedance between the two windings. It is normally designated in per unit or percent by the transformer and stamped on the transformer nameplate. Unless otherwise specified, this value is on the self-cooled kVA or MVA rating at the rated voltages.

It can be measured by shorting one winding and applying voltage to the other winding. This voltage should not cause the transformer to saturate. From [Figure A4.2-2](#),

$$Z_T = \frac{V}{I} = Z_H + \frac{Z_L Z_e}{Z_L + Z_e}. \quad (\text{A4.2-1})$$

Because unsaturated Z_e is very large compared with Z_L , the term $Z_L Z_e / Z_L + Z_e$ approaches and is approximately equal to Z_L , so that for practical purposes

$$Z_T = \frac{V}{I} = Z_H + Z_L. \quad (\text{A4.2-2})$$

Z_T is measured in practice by circulating rated current (I_R), through one winding with the other shorted and measuring the voltage (V_W) required to circulate this rated current. Then,

$$Z_T = \frac{V_W}{I_R} \Omega. \quad (\text{A4.2-3})$$

This test can be done for either winding or as convenient. On the measured side, the base impedance will be

	Transformer bank connection	Positive and negative sequence connections	Zero sequence connection
a		N_1 or N_2 	
b		N_1 or N_2 	
c		N_1 or N_2 	
d		N_1 or N_2 	
e		N_1 or N_2 	
f		N_1 or N_2 	
g		N_1 or N_2 	
h		N_1 or N_2 	

FIGURE A4.2-1 Sequence connections for typical two-winding transformer banks.

$$Z_B = \frac{V_R}{I_R} \Omega, \quad (\text{A4.2-4})$$

where V_R and I_R are the rated voltage and current, respectively.

Then, the per-unit impedance from Equation 2.1 is

$$Z_T = \frac{Z_T(\Omega)}{Z_B(\Omega)} = \frac{V_W I_R}{I_R V_R} = \frac{V_W}{V_R} \text{ pu}. \quad (\text{A4.2-5})$$

For three-phase-type transformer units, the nameplate should specify this Z_T , usually in percent, on the three-phase kVA (MVA) rating, and the kV line-to-line voltages. When several kVA (MVA) ratings are specified, the normal rating, without fans, pumps, and such (lowest) rating, should be used as one of the impedance bases.

For individual single-phase transformers, the transformer impedance is normally specified on a single-phase kVA (MVA) and the rated winding voltages (kV) of the transformer. When three such units are used in three-phase systems, then the three-phase kVA (MVA) and line-to-line voltage (kV) bases are required, as outlined in Chapter 2.

Thus, when three individual single-phase transformers are connected in the power system, the individual nameplate percent or per-unit impedance will be the Z_T leakage impedance, but only on the three-phase kVA (MVA) base, and the system line-to-line kV.

Example: Impedance of Single-Phase Transformers in Three-Phase Power Systems

Consider single-phase transformers, each with a nameplate rating of 20 MVA, 66.5 kV: 13.8 kV, $X = 10\%$. Considering the individual transformer alone, its leakage reactance is

$$X_T = 0.10 \text{ pu on 20 MVA, 66.5 kV or} \quad (\text{A4.2-6})$$

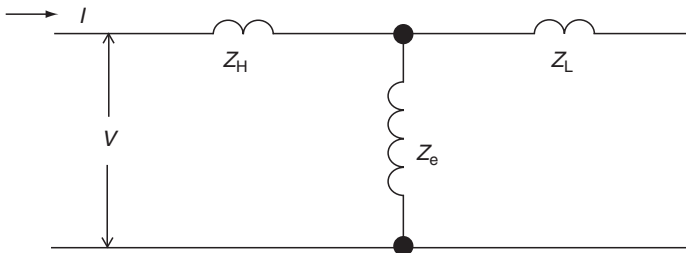

FIGURE A4.2-2 Simplified equivalent diagram for a transformer: Z_H and Z_L are the components of the transformer leakage impedance and Z_e is the exciting impedance. All values are in per unit or primary H side ohms.

$$X_T = 0.10 \text{ pu on 20 MVA, 13.8 kV.}$$

Converting these to actual ohms using Equation A4.2-5, $V_{WH} = 0.10 V_{RH} = 0.10 \times 66,500 = 6650$ volts on the high side, where $I_{RH} = 20,000/66.5 = 300.75$ amperes primary.

Then, we obtain from Equation A4.2-3,

$$X_{TH} = \frac{6650}{300.75} = 22.11 \Omega \text{ primary} \quad (\text{A4.2-7})$$

or on the secondary side, $V_{WL} = 0.10 \times 13,800 = 1380$ V, and $I_{RL} = 20,000/13.8 = 1449.28$ amperes secondary.

$$X_{TL} = \frac{1380}{1449.28} = 0.952 \Omega \text{ secondary.} \quad (\text{A4.2-8})$$

Check:

$$\left(\frac{66.5}{13.8}\right)^2 \times 0.952 = 22.11 \Omega \text{ primary.}$$

Now consider two possible applications of three of these individual transformers to a power system. These are intended to demonstrate the fundamentals; do not consider if the transformer windings are compatible or suitable for the system voltages shown.

Case 1

Connect the high-voltage windings in wye to a 115 kV system and the low-voltage windings in delta to a 13.8 kV system. As indicated previously, the leakage impedance of this transformer bank for this application is

$$X_T = 0.10 \text{ pu on 60 MVA, 115 kV,}$$

$$X_T = 0.10 \text{ pu on 60 MVA, 13.8 kV.} \quad (\text{A4.2-9})$$

Now Let us check this. From Equation 2.17,

$$X_{TH} = \frac{115^2 \times 0.10}{60} = 22.11 \Omega \text{ primary,}$$

$$X_{TL} = \frac{13.8^2 \times 0.10}{60} = 0.317 \Omega \text{ secondary.} \quad (\text{A4.2-10})$$

It will be noted that the individual transformer reactance per Equation A4.2-8 is 0.952Ω , but this is the reactance across the 13.8 kV because of the delta connection. The equivalent wye impedance can be determined by the product

of the two-delta branches on either side of the desired wye branch divided by the sum of the three-delta branches. Thus, the wye equivalent is

$$\frac{(0.952)0.952}{(3)0.952} = \frac{0.952}{3} = 0.317 \Omega \text{ as before}$$

Check

$$\left(\frac{115}{13.8}\right)^2 \times 0.317 = 22.1 \Omega \text{ primary}$$

Case 2

Connect the high-voltage windings in delta to a 66.5 kV system and the low-voltage side in wye to a 24 kV system. Now the transformer bank impedance for this system application is

$$\begin{aligned} X_T &= 0.10 \text{ pu on 60 MVA, 66.5 kV} \quad \text{or} \\ X_T &= 0.10 \text{ pu on 60 MVA, 24 kV.} \end{aligned} \quad (\text{A4.2-11})$$

Now to check this by converting to ohms, using [Equation 2.17](#)

$$X_{TH} = \frac{66.5^2 \times 0.10}{60} = 7.37 \Omega \text{ primary} \quad (\text{A4.2-12})$$

is obtained.

Now this primary winding of 22.11 ohms ([Equation A4.2-7](#)) is connected across the 66.5 kV system because of the delta. Accordingly, the equivalent wye reactance is $22.11 \times 22.11/3 = 163.8$ ohms line-to-line on the primary side.

On the secondary side, $X_{TL} = 24^2 \times 0.10/60 = 9.6$ ohms secondary as [Equation A4.2-8](#).

Check

$$\left(\frac{66.5}{24}\right)^2 \times 9.6 = 163.8 \Omega \text{ primary.}$$

The connections of two-winding transformers in the sequence networks are documented in [Figure A4.2-1](#). Note that the connections for positive and negative sequences are all the same and are independent of the bank connections. This is not true for the zero sequence with different connections for each type of bank.

Neutral impedance is shown for several connections. If the blanks are solid-grounded, the neutral impedance is zero, and the values shown are shorted-out in the system and are zero-sequence diagrams.

THREE-WINDING AND AUTOTRANSFORMER BANKS

Typical banks are shown in [Figure A4.2-3](#). H, M, and L are the high-, medium-, and low-voltage windings. These designations can be interchanged as required. Normally, the manufacturer provides the leakage impedance between the windings as Z_{HM} , Z_{HL} , and Z_{ML} , usually on different kVA or MVA ratings and at the rated winding voltages.

To use these impedances in the sequence networks, they must be converted to an equivalent wye-type network, as shown. This conversion is

$$Z_H = \frac{1}{2}(Z_{HM} + Z_{HL} - Z_{ML}), \quad (\text{A4.2-13})$$

$$Z_M = \frac{1}{2}(Z_{HM} + Z_{ML} - Z_{HL}), \quad (\text{A4.2-14})$$

$$Z_L = \frac{1}{2}(Z_{HL} + Z_{ML} - Z_{HM}). \quad (\text{A4.2-15})$$

It is easy to remember this conversion, for the equivalent wye value is always half the sum of the leakage impedances involved, minus the one that is not involved. For example, Z_H is half of Z_{HM} , both involving H and minus Z_{ML} that does not involve H.

After determining Z_H , Z_M , and Z_L , a good check is to see if they add up as $Z_H + Z_M = Z_{HM}$, If these values are not available, they can be measured as described for a two-winding transformer. For the three-winding or autotransformers: Z_{HM} is the impedance looking into H winding with M shorted, L open; Z_{HL} is the impedance looking into H winding, with L shorted, M open; Z_{ML} is the impedance looking into M winding, with L shorted, H open.

This equivalent wye is a mathematical network representation valid for determining currents and voltages at the transformer terminals or in the associated system. The wye point has no physical meaning. Quite often, one of the values will be negative and should be used as such in the network. It does not represent a capacitor.

The positive- and negative-sequence connections are all the same and independent of the actual bank connections. However, the connections for the zero-sequence network are all different and depend on the transformer bank connections. If the neutrals are solidly grounded, then the Z_N and $3Z_N$ components shown are shorted-out in the system and sequence circuits.

	Transformer bank connection	Positive and negative sequence connections	Zero sequence connection
a		N_1 or N_2 	<p>If solid grounded $Z_N = 0$</p>
b		N_1 or N_2 	<p>If solid grounded Z_{NH} and/or $Z_{NM} = 0$</p>
c		N_1 or N_2 	<p>If solid grounded $Z_N = 0$</p>
d		N_1 or N_2 	

FIGURE A4.2-3 Sequence connections for typical three-winding and autotransformer banks.

Appendix 4.3

Sequence Phase Shifts through Wye–Delta Transformer Banks

As has been indicated, positive and negative sequences pass through the transformer bank, and in the sequence networks, the impedance is the same, independent of the bank connection. This is shown in [Figure A4.2-1](#) and [Figure A4.2-3](#). In these networks the phase shift is ignored, but if currents and voltages are transferred from one side of the transformer bank to the other, these phase shifts must be taken into account. This appendix will document these relations. For this the standard ANSI connections are shown in [Figure A4.3-1](#).

From Figure A4.3-1a, all quantities are phase-to-neutral values, and in amperes or volts; for per unit, $N = 1$, $n = 1/\sqrt{3}$.

$$I_A = n(I_a - I_c) \text{ and } V_a = n(V_A - V_B).$$

For positive sequence (see [Equation 4.2](#)),

$$\begin{aligned} I_{A1} &= n(I_{a1} - aI_{a1}) = n(1 - a)I_{a1} \\ &= \sqrt{3}nI_{a1} \angle -30^\circ = NI_{a1} \angle -30^\circ, \end{aligned} \quad (\text{A4.3-1})$$

$$\begin{aligned} V_{a1} &= n(V_{A1} - a^2V_{A1}) = n(1 - a^2)V_{A1} \\ &= \sqrt{3}nV_{A1} \angle +30^\circ = NV_{A1} \angle +30^\circ. \end{aligned} \quad (\text{A4.3-2})$$

For negative sequence (see [Equation 4.3](#)),

$$\begin{aligned} I_{A2} &= n(I_{a1} - a^2I_{a1}) = n(1 - a^2)I_{a2} \\ &= \sqrt{3}nI_{a2} \angle +30^\circ = NI_{a2} \angle +30^\circ, \end{aligned} \quad (\text{A4.3-3})$$

$$V_{a2} = n(V_{A2} - aV_{A2}) = n(1 - a)V_{A2}, \quad (\text{A4.3-4})$$

$$= \sqrt{3}nV_{A2} \angle -30^\circ = NV_{A2} \angle -30^\circ. \quad (\text{A4.3-5})$$

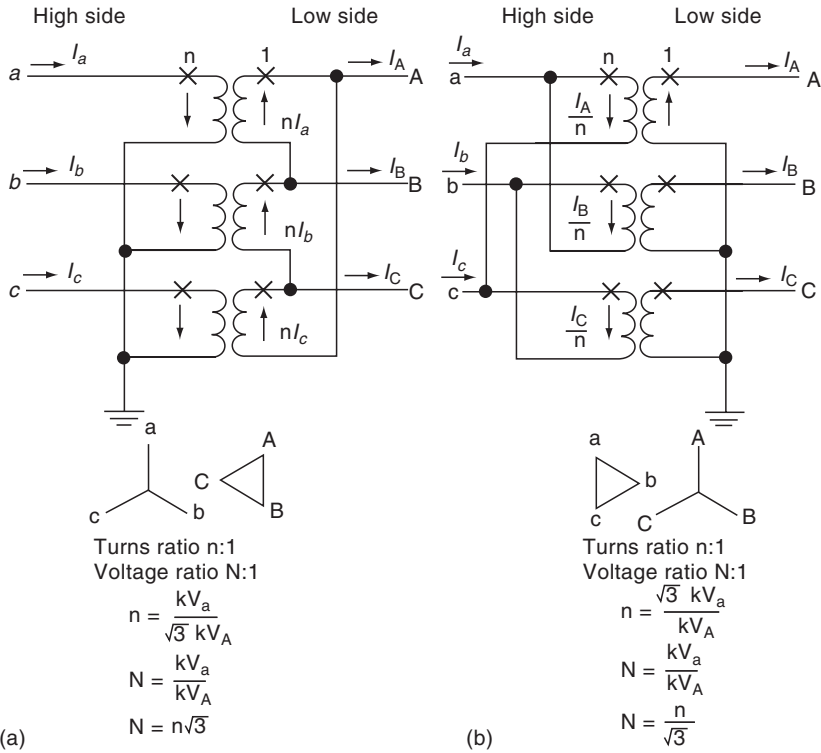

FIGURE A4.3-1 ANSI-connected wye–delta transformer banks: the high-voltage side phase *a* leads the low-voltage side phase *a* for both connections illustrated: (a) wye (star) on high side; (b) delta on high side.

5 Relay Input Sources

5.1 INTRODUCTION

Protective relays require reasonably accurate reproduction of the normal, tolerable, and intolerable conditions in the power system for correct sensing and operation. This information input from the power system is usually through current transformer (CT) and voltage transformer (VT). An exception is for temperature-type relays that receive their information from thermocouples or temperature indicators.

These devices—CTs, VTs, formerly potential transformers (PTs), and coupling capacitor voltage transformers (CCVTs)—provide insulation from the higher-system voltages and a reduction of the primary current and voltage quantities. Thus, primary source of the transformer is connected into or to the power system with insulation that is compatible with that of the system. The secondary source is standardized for the convenience of application and relay design. These relay input sources are an important member of the protection “team.” Typical units are illustrated in [Figure 5.1](#) through [Figure 5.5](#), and also see [Figure 1.8](#).

Other means of providing power system information for protective relays are developed and finding applications. One is the magneto-optic current transducer. This uses the Faraday effect to cause a change in light polarization passing through an optically active material in the presence of a magnetic field. The passive sensor at line voltage is connected to a stationary equipment through a fiber-optic cable. This eliminates the supports for heavy iron cores and insulating fluids.

The output is low energy, and can be used with microprocessor relays and other low-energy equipment. These are most useful at the higher voltages using live tank circuit breakers that require separate CTs.

In the meantime, iron-cored devices are ubiquitous in power systems and do not appear to be easily replaced.

The intolerable system problems may be transient or permanent, and may involve a change in the primary current or voltage over a wide range. This is particularly true for the current, which can suddenly change from a few amperes to several hundred amperes within seconds, when a fault occurs. Voltages during faults can collapse, from the rated value down to zero.

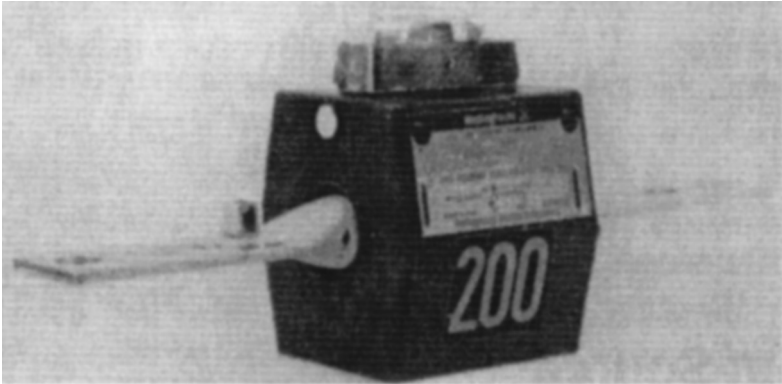

(a)

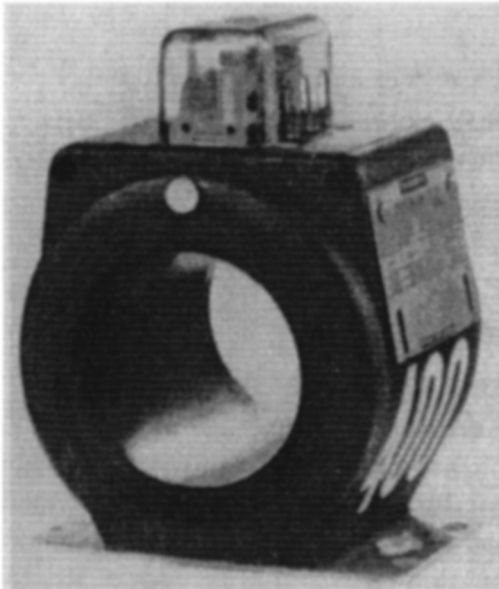

(b)

FIGURE 5.1 Typical low-voltage current transformers: (a) bar type, with the bar as the primary; (b) through-type, where the primary cable is passed through the CT opening. (Courtesy of Westinghouse Electric Corporation.)

5.2 EQUIVALENT CIRCUITS OF CURRENT AND VOLTAGE TRANSFORMERS

The equivalent diagrams for an instrument transformer are shown in [Figure 5.6](#). The exciting magnetizing impedance Z_e in [Figure 5.6a](#) is shown in two parts: Z'_e is the one associated with the leakage flux within the transformer core and its related leakage reactance X ; Z''_e is associated with the flux that does not reach the core. X_p is the leakage reactance from this flux that does not cut the transformer core. R_p and R_s are the resistances of the primary and secondary windings, respectively.

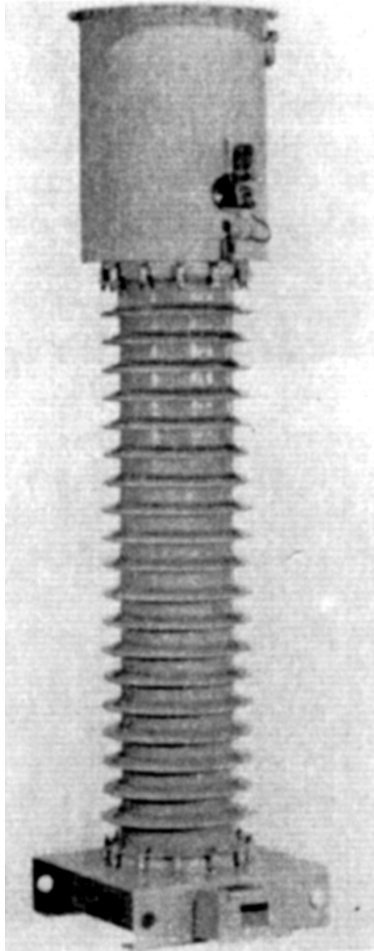

FIGURE 5.2 A 230 kV oil-filled current transformer. The unit is approximately 10 ft high and 2.5 ft in diameter. (Courtesy of Westinghouse Electric Corporation.)

For VTs, the value of $(R_P + R_S) + j(X_P + X)$ is kept low to minimize the loss of voltage and shift of the phase angle from primary to secondary. CTs are of two types; those with significant leakage flux in the core (see Figure 5.6a) and those with negligible leakage flux in the core (see Figure 5.6b). In either type, the Z_e shunt impedance(s) are kept high to minimize current loss from the primary to the secondary.

The perfect or ideal transformers shown in the diagram are to provide the necessary ratio change; they have no losses or impedances. Although shown in the primary, they may be connected the secondary. As shown, all the impedances are on a secondary basis. With per-unit nomenclature, the perfect transformers are omitted because they are not required.

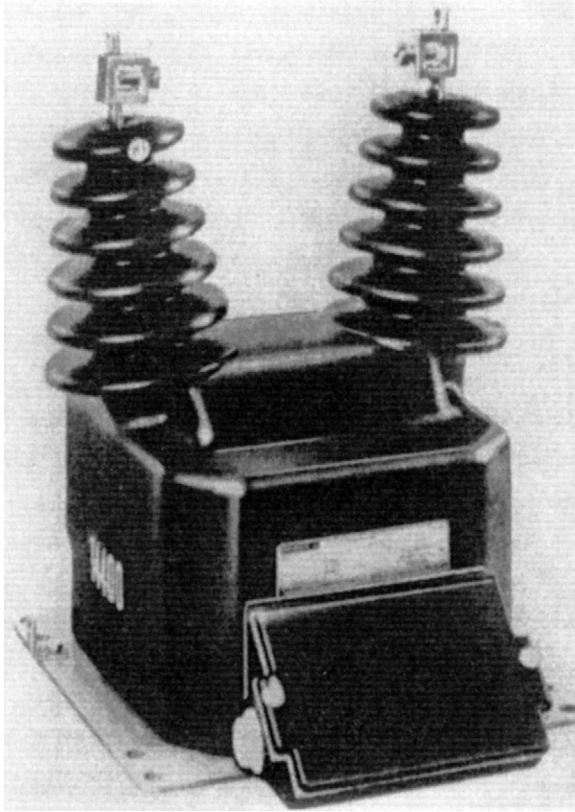

FIGURE 5.3 Voltage transformer for use in low-voltage power systems. (Courtesy of Westinghouse Electric Corporation.)

The primary quantities are reduced by the turns ratio n to provide a secondary current or voltage to energize protective relays and other equipment. The impedances of these loads are commonly called *burden*. The term can refer to individual devices or to the total load connected, including the instrument transformer secondary impedance, when that is significant. For the devices, the burden is often expressed in volt–amperes at a specified current or voltage. Thus, for CTs or VTs, the burden impedance Z_B is

$$Z_B = \frac{VA}{I^2} \Omega \text{ (for CTs) or } = \frac{V^2}{VA} \Omega \text{ (for VTs),} \quad (5.1)$$

where VA is the volt–ampere burden and I or V the amperes or volts at which the burden was measured or specified.

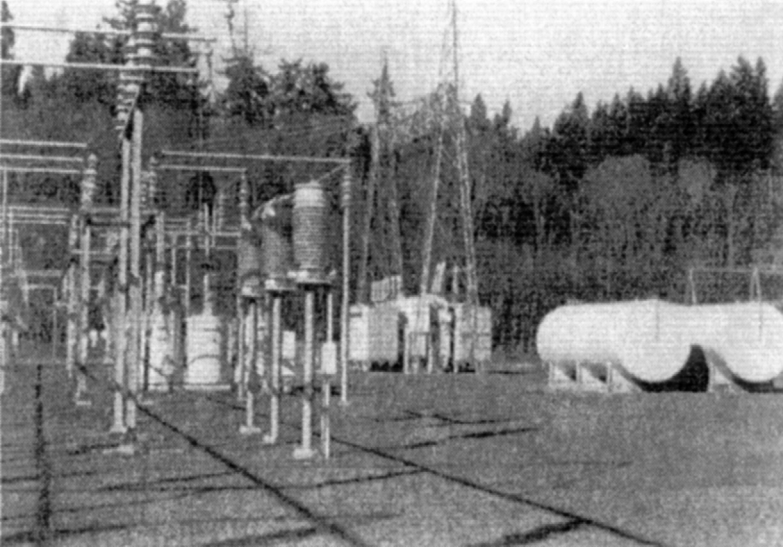

FIGURE 5.4 Typical 115 kV switchyard with three 115 kV voltage transformers in the foreground, mounted on top of a 10 ft pipe. Behind are oil circuit breakers and in the right rear, a 325 MVA, 230:115 kV autotransformer bank. (Courtesy of Puget Sound Power & Light Co.)

5.3 CURRENT TRANSFORMERS FOR PROTECTION APPLICATIONS

Almost all CTs universally have 5 A secondary ratings. Other ratings, such as 1 A, exist, but are not common, although they are used in other countries. Advantages for this lower rating may exist when unusually long secondary leads are required between the CTs and the relays, such as in high-voltage (HV) installations. However, changing the CT rating does not necessarily reduce the energy required for relay operation. With a constant VA, lower current means higher voltage, and more insulation between the primary and the secondary. For the most part, the advantages appear to be offset by the disadvantages. Presently and in the future, solid-state microprocessor relays, with very low burdens, greatly reduces the concern of burden on instrument transformers.

The measure of a CT performance is its ability to reproduce accurately the primary current in secondary amperes, both in wave shape and magnitude. There are two parts: (1) the performance on the symmetrical AC component and (2) the performance on the offset DC component. Modern CTs do a remarkable job of reproducing wave shapes, as long as they do not saturate.

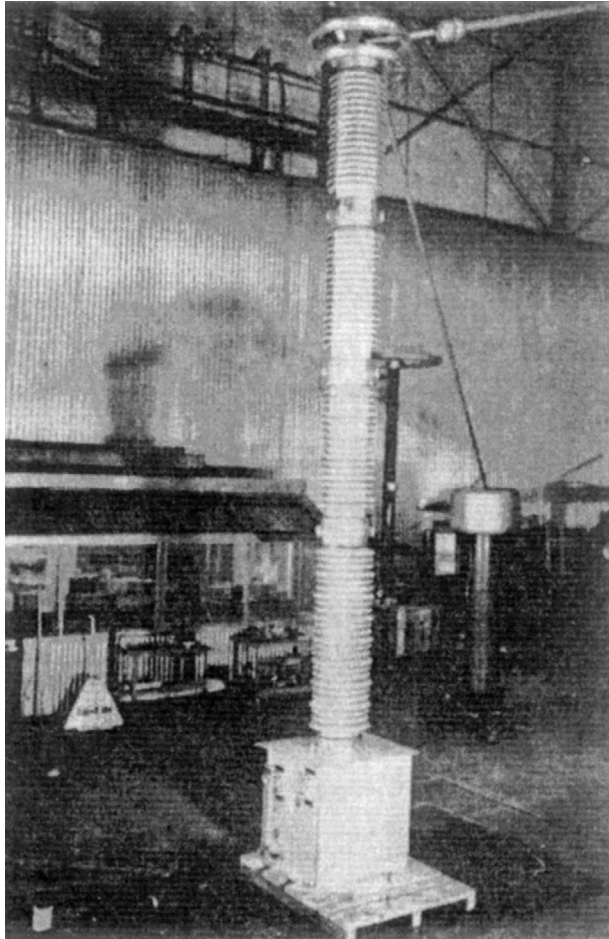

FIGURE 5.5 A 500 kV coupling capacitor voltage transformer undergoing factory test and calibration. (Courtesy of Westinghouse Electric Corporation.)

5.4 CURRENT TRANSFORMER PERFORMANCE ON A SYMMETRICAL AC COMPONENT

For the symmetrical component, the performance is determined by the highest current that can be reproduced, without saturation, to cause large ratio errors. Phase-angle errors are not usually critical for relaying.

If the CT does not saturate, it is practicable to assume that I_c is negligible.

$$I_S = \frac{I_P}{R_c} \text{ amperes or } I_S = I_P \text{ per unit,} \quad (5.2)$$

where R_c is the CT ratio and equivalent to n in [Figure 5.6](#).

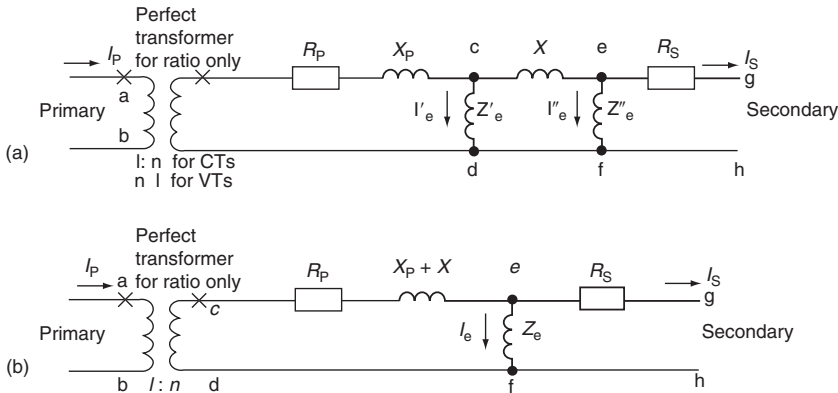

FIGURE 5.6 Equivalent diagrams for instrument transformers; with perfect (ideal) transformers for ratio primary to secondary as shown, the values are in secondary ohms ($n =$ turns). With per unit, omit the perfect transformers. (a) For significant leakage flux in transformer core—class T CTs and VTs; (b) for negligible leakage flux in transformer core—class C CTs.

For CTs connected in the phase leads of the power system with the load passing through them, the ratio R_c is selected so that the maximum anticipated secondary current does not exceed 5 A secondary. This comes from the long-standing practice of indicating the instrument movements standardized at 5 A, independent of the primary ampere scale markings. By selecting a ratio to give a little less than 5 A at the maximum load, any instrument connected in the circuit would not go off scale. Instruments may or may not be connected in the relay circuits, but this practice continues, with the continuous ratings of the CTs and relays, often based on 5 A.

However, I_e , the CT-exciting current, is never zero if the CT is energized either by the primary or the secondary current. Thus, it must be checked to assure that it is negligible. This can be done by one of three methods: (1) classic transformer formula, (2) CT performance curves, or (3) ANSI/IEEE accuracy classes for relaying.

5.4.1 PERFORMANCE BY CLASSIC ANALYSIS

The classic transformer formula is

$$V_{ef} = 4.44 f N A \beta_{\max} \times 10^{-8} \text{ V}, \quad (5.3)$$

where f is the frequency in hertz, N the number of secondary turns, A the iron-core cross-sectional area in square inches, and β_{\max} the iron-core flux density

in lines per square inch. However, most of these quantities are not normally available, so this method is used primarily by CT designers. V_{ef} is the voltage the CT can develop to drive secondary current through the load.

This load on the CTs consists of its secondary resistance R_S , the impedance of the connecting leads Z_{ld} , and the equipment (relays and such) Z_r . The voltage required by the burden (load) is

$$V_{ef} = I_S(R_S + Z_{ld} + Z_r) \text{ volts.} \quad (5.4)$$

5.4.2 PERFORMANCE BY CT CHARACTERISTIC CURVES

The calculation of the performance with the equivalent circuit of [Figure 5.6a](#) is difficult, even when the value of X is known. The ANSI/IEEE Standard (C57.13) for instrument transformers recognizes this and classified CTs that have significant leakage flux within the transformer core as class T (class H before 1968). Wound CTs, those that have one or more primary-winding turns mechanically encircling the core, are usually of the class T. Their performance is best determined by test, with the manufactures providing curves, as shown in [Figure 5.7](#).

CTs constructed to minimize the leakage flux in the core, such as the through, bar, and bushing types (see [Figure 5.1](#)), can be represented by the modified equivalent circuit of [Figure 5.6b](#). Effectively, the leakage reactance X is ahead of the exciting branches, and these branches can be paralleled to Z_e . With this the performance can be calculated. These are designated as class C (class L before 1968). Typical class C excitation curves are shown in [Figure 5.8](#) and also [Figure 5.11](#).

The *knee* or *effective point of saturation* is defined by the ANSI/IEEE Standard as the intersection of the curve with a 45° tangent line. However, the International Electrotechnical Commission (IEC) defines the knee as the intersection of straight lines extended from the nonsaturated and the saturated parts of the exciting curve. The IEC knee is at a higher voltage than the ANSI knee, as shown in [Figure 5.8](#).

5.4.3 PERFORMANCE BY ANSI/IEEE STANDARD ACCURACY CLASSES

In many applications, the use of the ANSI/IEEE accuracy class designations is adequate to assure satisfactory relay performance. As indicated, there are two standard classes: class T, for which performance is not easy to calculate, so manufacturer's test curves must be used (see [Figure 5.7](#)), and class C, for which the performance can be calculated. These designations are followed by a number, indicating the secondary terminal voltage (V_{gh}) that the transformer can deliver to a standard burden at 20 times the rated secondary current, without exceeding the 10% ratio correction ([Figure 5.9](#)). This 10% will not be

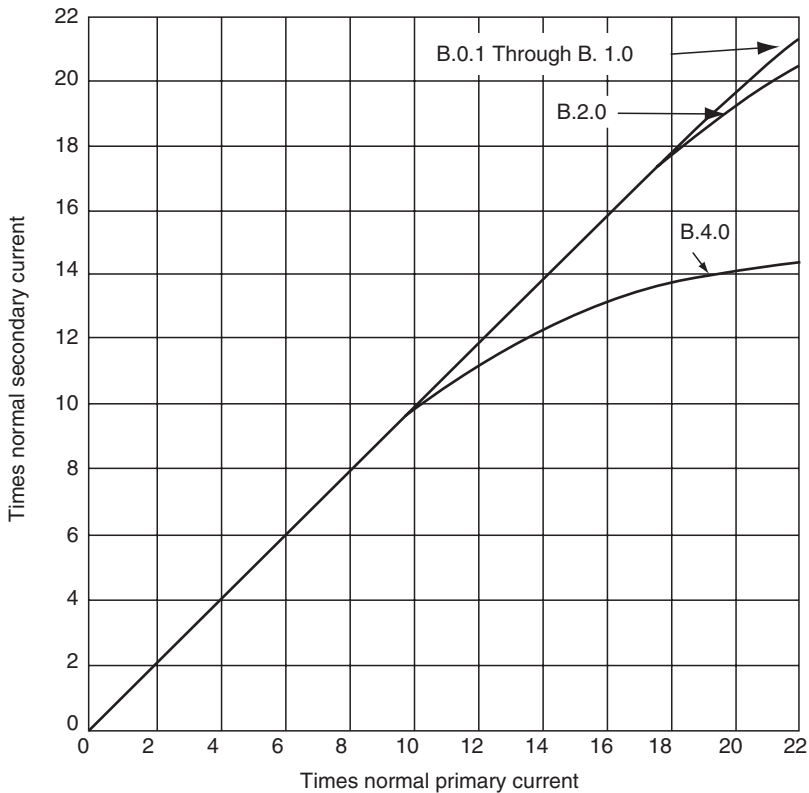

FIGURE 5.7 Typical overcurrent ratio curves for class T current transformers. (Figure 5 of ANSI/IEEE Standard C37.13.)

exceeded at any current from 1 to 20 times the rated secondary current at the standard burden or any lower standard burden. For relaying, the voltage classes are 100, 200, 400, and 800, corresponding to standard burdens of B-1, B-2, B-4, and B-8, respectively. These burdens are at 0.5 power factor. The burden numbers are ohms, obtained by dividing the voltage rating by 20 times the rated secondary current. Thus, with the 800 V rating and its associated B-8 burden, $8 \Omega \times 5 \text{ A} \times 20 = 800 \text{ V}$.

If the current is lower, the burden can be higher in proportion; however, this does not necessarily apply to higher currents because the internal impedance, basically neglected in the standard, can affect performance. Therefore, a 400 V rated CT will pass 100 A (20 times rated) with a burden of 4 Ω or less, with not more than 10% ratio error. Correspondingly, it can pass 50 A with an 8 Ω burden with not more than the 10% error.

For these voltage ratings, terminal voltage is used, rather than the excitation voltage of [Equation 5.4](#), or

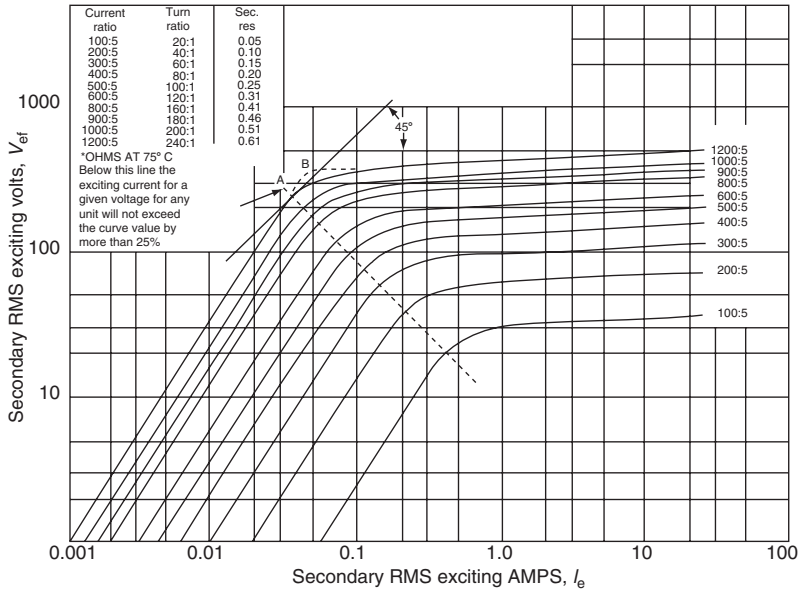

FIGURE 5.8 Typical excitation curves for a multiratio class C current transformer: Point A is the ANSI knee. Above this line, the voltage for a given exciting current for any unit will not be less than 95% of the curve value. Point B is the IEC knee. (Figure 4 of ANSI/IEEE Standard C57.13-1978.)

$$V_{gh} = I_S(Z_{ld} + Z_r) V. \quad (5.5)$$

The lower-voltage classes of 10, 20, and 50 with standard burdens of B-0.1, B-0.2, and B-0.5 at 0.9 power factor are primarily for metering service, and should be used very cautiously for protection.

Two similar CTs connected in the primary circuit, with the same ratio and their secondaries in series, will increase the accuracy capability. As an example, first consider a single 200/5 ($R_c = 40$), with a total burden of 0.5 Ω . The primary current is 3200 A. Then the current through the relay (burden) will be $3200/40 = 80$ A secondary, neglecting any saturation, and the CT must be capable of developing $80 \times 0.5 = 40$ V secondary.

At this point, with two 200/5 CTs in the primary and their secondaries in series, 80 A will flow through the relays. The voltage across the relays will be 40 V, but each CT needs to develop only 20 V.

Two similar CTs, with their secondaries in parallel, provide an overall lower ratio with higher-ratio individual CTs and their correspondingly higher-accuracy rating. For the foregoing example, use two 400/5 ($R_c = 80$) CTs, instead of 200/5 CTs. Then the CT secondary current is $3200/80 = 40$ A, but the current through the relays is 80 A, and the voltage across the relays and

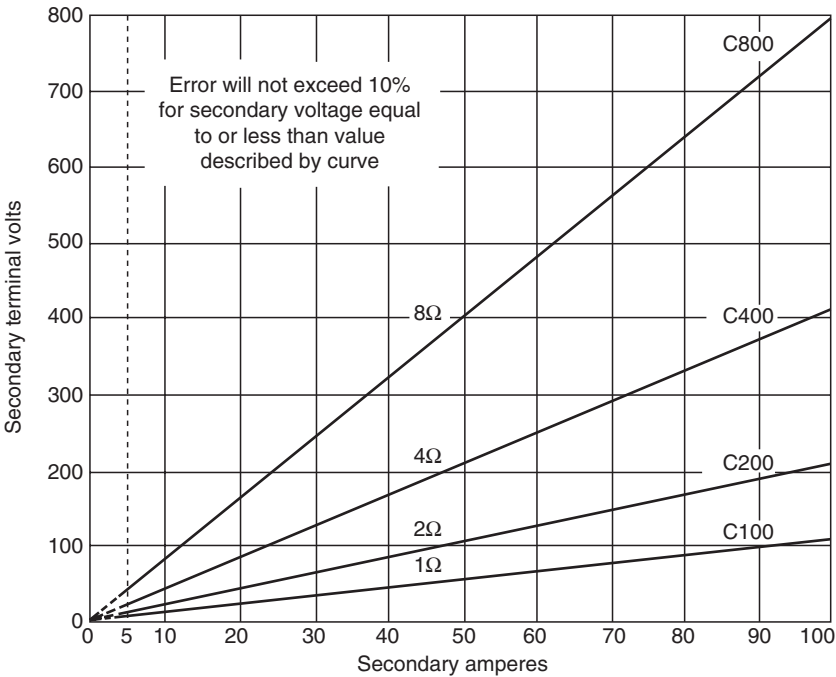

FIGURE 5.9 Secondary voltage capabilities for various class C current transformers.

each CT is 40 V. This is the same voltage as that for the single CT, but now with the higher-accuracy class 400/5 CTs.

The use of two CTs may be quite helpful when low-ratio CTs are used because of low feeder loads, but the close-in fault current can be very high. The low CT accuracy can result in failure or poor operation of the protection.

It should be appreciated that the ANSI classifications merely indicate that the ratio correction or error will not exceed 10%. They do not provide information on the actual value, which may be any value, but not exceeding 10%. Also significantly, these accuracy class values apply only to the full winding, and are reduced proportionally when lower taps are available and used. Many type-C transformers are bushing multiratio type, with five secondary taps, providing ratios such as those shown in Figure 5.8 (see also Figure 5.11). Performance on these lower taps is significantly reduced and limited. As a general rule, the use of the lower-ratio taps should be avoided, and when used, the performance should be checked.

According to the standards, the manufacturer is to supply application data for relaying service of CTs of (1) the accuracy class, (2) short-time mechanical and thermal ratings, (3) resistance(s) of the secondary winding, and

(4) typical curves, such as [Figure 5.7](#) for class T and [Figure 5.8](#) for class C (see also [Figure 5.11](#)).

5.4.4 IEC STANDARD ACCURACY CLASSES

The IEC specifies the accuracy of CTs as

15 VA Class 10 P 20
Accuracy limit factor
For protection
Accuracy class
Continuous VA

Thus, for this CT rated at 5 A, $15/5 = 3$ V, and will have no more than 10% error up to $20 \times 3 = 60$ V secondary.

Standard values for relaying CTs are

Continuous VA: 2.5, 5, 10, 15, and 30
Accuracy classes: 5% and 10%
Accuracy-limit factor: 5, 10, 15, 20, and 30
Rated secondary amperes: 1, 2, and 5 (5 A preferred)

For a CT rated 30 VA class 10 P 30,

$$\frac{30}{5} = 6 \text{ V}; 6 \times 30 = 180 \text{ V}.$$

The permissible burden is $30/5^2 = 1.2 \Omega$. This is equivalent to an ANSI/IEEE C180 current transformer.

5.5 SECONDARY BURDENS DURING FAULTS

The burden imposed on CTs for various faults and connections is documented in [Figure 5.10](#). Z_B is the sum of the leads or connecting circuits between the CTs and the relays, and also the relays and other equipment. It is assumed that the burden in each phase is the same, but this may not be correct always. When the CTs are connected in delta (see [Figure 5.10b](#)), the burden on the phase A current transformer is $(I_A - I_B)Z_B - (I_C - I_A)Z_B$. This reduces to $[2I_A - (I_B + I_C)Z_B]$. For a three-phase fault, $I_A + I_B + I_C = 0$, so $(I_B + I_C) = -I_A$, and substituting this, the burden reduces to $3I_A Z_B$.

Because phase relays are set on three-phase fault currents, and ground relays are set on single-phase-to-ground fault currents, the phase-to-phase fault diagrams are not generally used. They certainly indicate that the burden is the same as that of three-phase faults, and with less phase-to-phase fault current, the three-phase fault cases are the maximum.

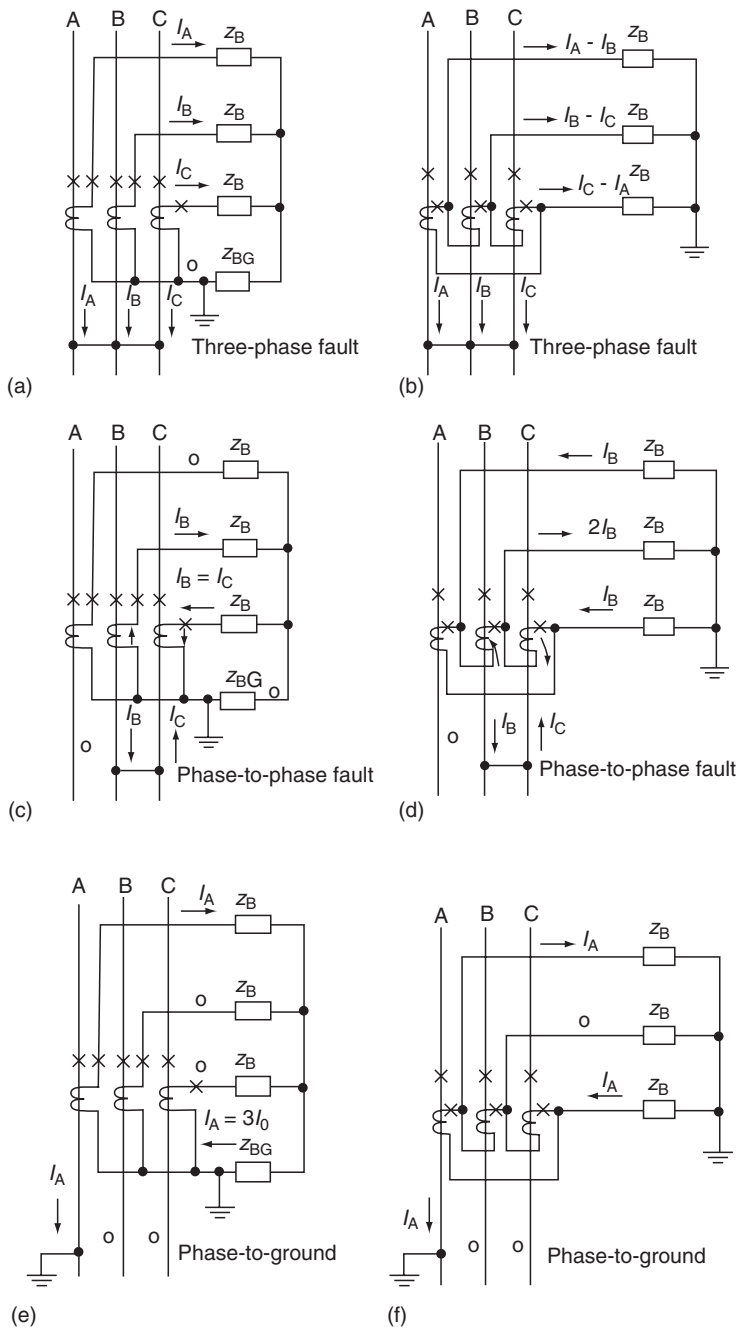

FIGURE 5.10 Burdens on CTs for various types of CT connections and faults. The unexcited CT load is neglected.

5.6 CT SELECTION AND PERFORMANCE EVALUATION FOR PHASE FAULTS

A suggested process for selection of the CT ratio and evaluation of its performance can be shown by an example. Consider a circuit to be protected by overcurrent relays with the following load and fault levels:

$$\begin{aligned}I_{\max \text{ load}} &= 90 \text{ A}, \\I_{\max 30 \text{ fault}} &= 2500 \text{ A}, \\I_{\min \text{ fault}} &= 350 \text{ A}.\end{aligned}$$

5.6.1 CT RATIO SELECTION FOR PHASE-CONNECTED EQUIPMENT

Select the ratio, such that the maximum short time or continuous current will not exceed the thermal limits of the CT secondary and connected equipment. The conventional practice, over many years, has been to set the secondary current just under 5 A for the maximum load. This was because instruments were often in the same circuit and had 5 A movements. Following this practice, select the CT ratio of 100/5 ($R_c = 20$). This gives a maximum continuous secondary current, when the load is 90 A, of $I_S = 90/20 = 4.5$ A.

5.6.2 SELECT THE RELAY TAP FOR THE PHASE-OVERCURRENT RELAYS

Overcurrent taps represent the minimum pickup or operating current of an overcurrent relay. Thus, a tap that is higher than the maximum load is chosen; in this example, above 4.5 A. How much higher is based on relay characteristics, experience, and judgment. There is no problem if a time overcurrent relay picks up on a cold load, offset currents, or others, provided these currents subside below the relay pickup before it operates. This may be required when the margin between minimum fault and maximum load is small.

Small tap 5 is selected. The ratio above load $5/4.5 = 1.1$. This provides a small margin more than any potential increase in the continuous load, but a large margin with inverse-type relays for transient overcurrents, such as a cold load. Minimum fault of $350/20 = 17.5$ A, and $17.5/5 = 3.5$ times the minimum relay pickup that is desirable for any possible fault restriction.

If tap 6 were selected, then the margin above load is greater ($6/4.5 = 1.33$), but a smaller margin ($17.5/6 = 2.9$) above the relay pickup.

5.6.3 DETERMINE THE TOTAL CONNECTED SECONDARY LOAD (BURDEN) IN OHMS

The total connected secondary load determination must include all of the impedances between the CTs and the equipment (relays) in the phase circuit. Ground relays are discussed in [Section 5.7](#). Data on the relays must be

obtained from the manufacture for the particular type. The burdens of solid-state and microprocessor-type relays are very low and relatively constant with taps. For these applications, the lead burden becomes the major load on the CTs.

Tap 5 will be used with electromechanical relays, for which the burden is 2.64 VA at 5 A and 580 VA at 20×100 A. The leads from the CT to the relays are 0.4Ω . The typical practice is to use number 8 or 10 sized leads for low resistance and to minimize mechanical damage to these important connections.

The total secondary impedance at pickup, adding directly:

$$\text{Relay burden } 2.64/5^2 = 0.106 \Omega$$

$$\text{Lead resistance} = 0.40 \Omega$$

$$\text{Total to CT terminals} = 0.458 \Omega \text{ at } 5 \text{ A}$$

The total secondary impedance at 20×100 A, adding directly:

$$\text{Relay burden } 580/100^2 = 0.058 \Omega$$

$$\text{Lead resistance} = 0.40 \Omega$$

$$\text{Total to CT terminals} = 0.458 \Omega \text{ at } 100 \text{ A}$$

This is typical for electromechanical relays that tend to saturate at higher currents. Thus, their internal impedance decreases and becomes more resistive. For these relays, the manufacturer will supply burden data at several current levels. Such reduced burdens aid CT performance. Subsequently, burdens for solid-state relays are low and more constant at various current levels.

It is frequently practical to add the burden impedances and the currents algebraically, but theoretically they should be combined phasorally. If the performance is marginal, combine phasorally; otherwise, direct addition is satisfactory and simpler. This is carried out in the example hitherto mentioned.

Burdens are generally near unity power factor; hence, I_S tends to be near unity power factor. However, I_e , the exciting current, lags 90° , so combining I_e and I_S at right angles is a good approximation.

5.6.4 DETERMINE THE CT PERFORMANCE USING THE ANSI/IEEE STANDARD

5.6.4.1 When Using a Class T CT

Check the performance from the curve provided, such as [Figure 5.7](#). The “B” represent the standard burdens. The relay burdens are B1, B2, B3, B4, and B8. These are the total secondary load impedances to the terminals gh in [Figure 5.6a](#), and would be the 0.506 or 0.458 values in the foregoing.

5.6.4.2 When Using a Class C CT and Performance by the ANSI/IEEE Standard

For this example, a 600/5 multiratio CT with C100 rating had been preselected. With this load, it would have been preferable to have selected lower-ratio CTs, but often the CTs are selected before adequate or correct system data are known. The choice of high ratio, multitap CTs appears to provide a wide range of possible system operations. However, it can give protection problems, as will be seen.

Determine the voltage at maximum fault that the CT must develop across its terminals (see gh in [Figure 5.6b](#)). This is

$$V_{\text{gh}} = \frac{2500}{20} \times 0.458 = 57.25 \text{ V},$$

but the C100 600/5 CT on the 100/5 tap can only develop,

$$V_{\text{gh}} = \frac{100}{600} \times 100 = 16.67 \text{ V}.$$

Thus, the maximum fault will cause severe saturation of the CT, resulting in incorrect or failure of the protection; consequently, the application cannot be used.

This application cannot be used with solid-state low-burden relays. Assume zero-relay burden, such that only the leads are considered. Then,

$$V_{\text{gh}} = 125 \times 0.4 \text{ (leads only)} = 50 \text{ V}.$$

Yet, the voltage required is way above the CT capability on the 100/5 tap of only 16.67 V.

An alternative is to use the 400/5 ($R_c = 80$) tap on the 600/5 C100 CT. Now the maximum load will be $90/80 = 1.125$ A, and a relay tap of 1.5 could be selected. This provides a $1.5/1.125 = 1.33$ margin between relay pickup and maximum load, and a margin of 2.9 between relay pickup and minimum fault ($350/80 = 4.38$; $4.38/1.5 = 2.9$).

However, the relay burden at this tap and at 100 A is 1.56Ω (however, for solid-state relays this would be much lower).

Relay burden = 1.56Ω
Lead resistance = 0.40Ω
Total to CT terminals = 1.96Ω

$$V_{\text{gh}} = \frac{2500}{80} \times 1.96 = 61.25 \text{ V}.$$

The CT capability on the 400/5 tap is

$$V_{\text{gh}} = \frac{400}{600} \times 100 = 66.7 \text{ V.}$$

The 61.25 V is within the CT capability.

5.6.4.3 When Using a Class C CT and Performance with the CT Excitation Curves

Use of the ANSI/IEEE ratings, as in the foregoing example, provides a “ball-park” evaluation that is usually quite adequate. The excitation curve method provides more accurate information when desired.

The excitation curve for the 600/5 CT of the example is shown in [Figure 5.11](#). When using these curves, the CT secondary resistance (R_S ; see [Figure 5.6b](#)) must be included. These data are shown in the table of [Figure 5.11](#) and for the 400/5 tap is 0.211. Thus,

Relay burden = 1.56 Ω
Lead resistance = 0.40 Ω
CT secondary = 0.211 Ω
Total to excitation point $ef = 2.171 \Omega$
The voltage to develop 1.5 A in the relays is

$$V_{\text{ef}} = 1.5 \times 2.171 = 3.26 \text{ V,}$$
$$I_e = 0.024 \text{ A.}$$

Directly adding $1.5 + 0.024$ for the worst case, the primary pickup would be $I_P = 1.524 \times 80 = 122.92 \text{ A}$. If we neglect the exciting branch, as is often done, $I_P = 1.5 \times 80 = 120 \text{ A}$. Both are well below the minimum fault of 350 A. This fault is 2.85 (2.92, neglecting the exciting current).

For the maximum fault of $2500/80 = 31.25 \text{ A}$ secondary,

$$V_{\text{ef}} = 31.25 \times 2.171 = 67.84 \text{ V,}$$
$$I_e = 0.16 \text{ A.}$$

Although this is near the knee of the saturation curve, the small excitation current does not significantly decrease the fault current to the relays.

5.7 PERFORMANCE EVALUATION FOR GROUND RELAYS

When ground relays are connected in the neutral-to-ground circuits of the power system ($3I_0$), or if I_0 is obtained from a transformer delta tertiary,

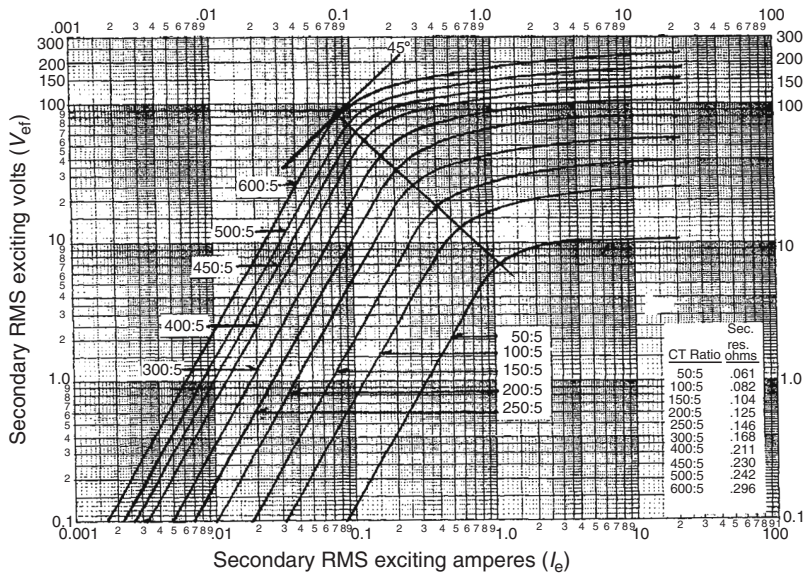

FIGURE 5.11 Typical excitation curves for a 600:5 multiratio class C100 current transformer.

the evaluation is similar to Section 5.6, except that Section 5.6.1 is not applicable because the positive sequence load current is not involved. If power circuits are connected to the transformer delta, CTs in each leg of the delta connected in parallel are necessary to provide $3I_0$.

For the common connection of the phase-and-ground relay in Figure 5.12, Section 5.6 applies with the ground criteria outlined in Figure 6.4.

Normally, ground relays can be set more sensitively than the phase relays, especially on higher-voltage circuits for which the zero-sequence unbalance is very small. On lower-voltage circuits, such as distribution lines, the effect of single-phase loading may result in ground relay settings that approximate those of the phase relays.

5.8 EFFECT OF UNENERGIZED CTs ON PERFORMANCE

CTs, with their secondaries interconnected, but with the primaries passing zero, or with negligible current, are excited from the secondary; thus, they will require I_e current. This can occur when paralleling CTs in a differential circuit, or during single-phase-to-ground faults. An example of the latter is illustrated in Figure 5.12. Fault I_A flows in that phase CT, but currents in the unfaulted phases B and C are zero. To emphasize the effect, assume that the 100:5 tap of a C100 600:5 multiratio CT is used. The secondary resistance of the CT, the leads, and the phase relay is given at 0.63Ω . The ground relay has

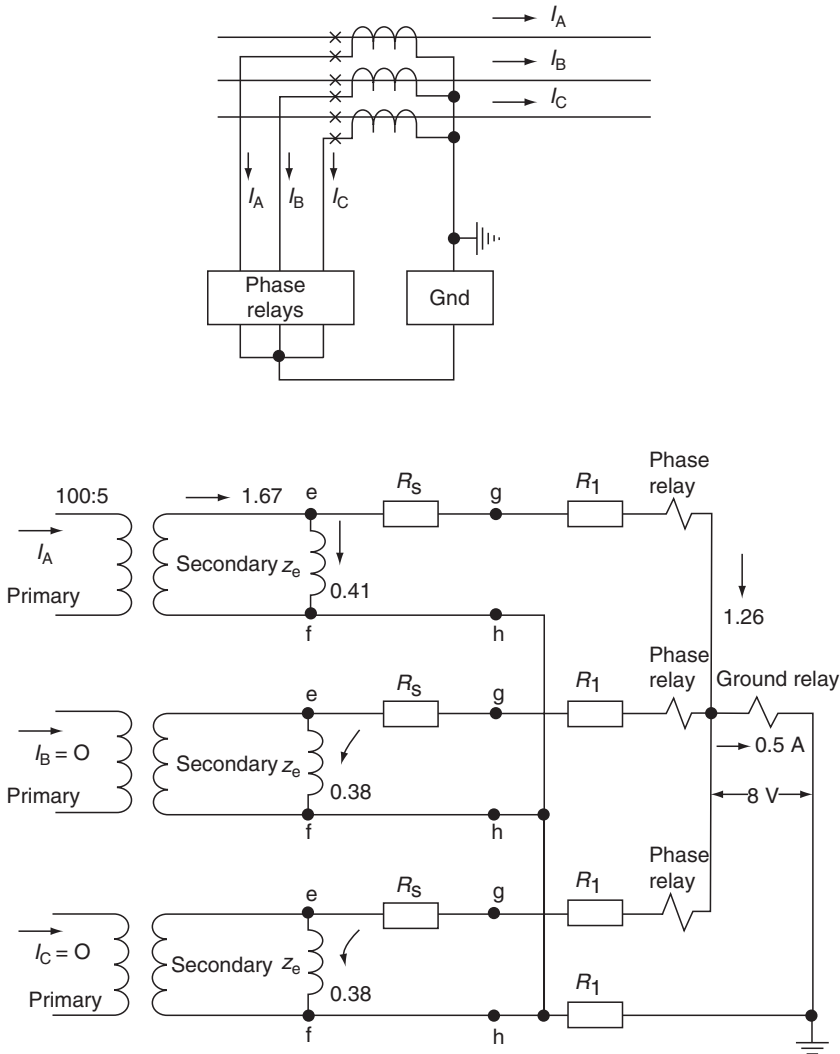

FIGURE 5.12 Phase-and-ground relays for the protection of a circuit and the current distribution for a phase-and-ground fault.

16 Ω on its 0.5 A tap 68° lag. To pass pickup current through the ground relay, $0.5 \times 16 = 18$ V is required. This voltage, less the small drop through the phase relay circuit, will appear across the phase B and C current transformer secondaries to excite them. The voltage V_{ef} depends on the current that, in turn, depends on the voltage, so the exact determination is a “cut-and-try” process. At the first try, assume that $V_{ef} = 8$ V. From the CT characteristic

(see Figure 5.11), I_e for 8 V = 0.39 A. This current through the phase circuit impedance results in a drop to make $V_{ef} = 8 - (0.39 \times 0.63) = 7.75$ V, where $I_e = 0.37$. Another iteration provides that $I_e = 0.38$ A, which is needed to excite both phase B and C current transformers. Any primary current would help offset this.

Thus, the current in the phase A circuit is the sum of the ground relay pickup and the phase B and C exciting currents. By direct addition, this would be $0.50 + 0.38 + 0.38 = 1.26$ A. By phasor addition, it would be essentially $0.5 \angle 68^\circ + j0.38 + j0.38 = 1.24 \angle 81.30^\circ$; therefore, the difference is not significant. The exciting voltage for the phase A CT is $V_{ef} = 8.0 + (1.26 \times 0.63) = 8.79$ V, whereas from Figure 5.11, $I_e = 0.41$ A. Directly adding, the total is $1.46 + 0.41 = 1.67$ secondary amperes or $20 \times 1.67 = 33.4$ primary amperes, just to pick up the ground relay. This is in contrast to the $20 \times 0.5 = 10$ primary amperes required just to pick up the ground relay, if the exciting currents for the three CTs were neglected.

It should be recognized that these CTs are not adequate for fault protection on the CT and ground relay taps used. As explained in Section 5.4.3, higher taps can improve performance and would decrease the shunting effect just described. This effect should be considered, especially when several CTs are paralleled with only one or two carrying current, as in a differential scheme, as described later.

5.9 FLUX SUMMATION CURRENT TRANSFORMER

Also known as doughnut or ring CT, flux summation CT consists of a magnetic core with a distributed winding. Power conductors are passed through the center opening. Typical openings are approximately 4–10 in. These CTs are useful in protection at the lower voltage.

When the three-phase conductors are passed through the opening, the secondary measures $I_a + I_b + I_c = 3I_0$, the ground current. When the same phase conductor on the two ends of a device are passed through the opening, the net current for a load or fault current passing through the device is zero. For an internal fault, with one or both supplying current of different magnitude or phase angle, the net or sum equals the fault current.

This is flux summation, rather than individual summing of separate transformer secondary currents. The advantages are that the CT ratio is independent of the load current or kVA of the circuit, and that it avoids the possible difficulties of unequal individual CT saturation or performance with paralleled CTs. The disadvantage is the limitation of the size of conductors that can be passed through the opening. A typical ratio for this CT is 50:5, and the diameter of the maximum opening is about 8 in.

The CT is commonly used with a 0.25 A instantaneous overcurrent unit. The combination provides a primary pickup of 5 A, rather than 2.5 A, if the

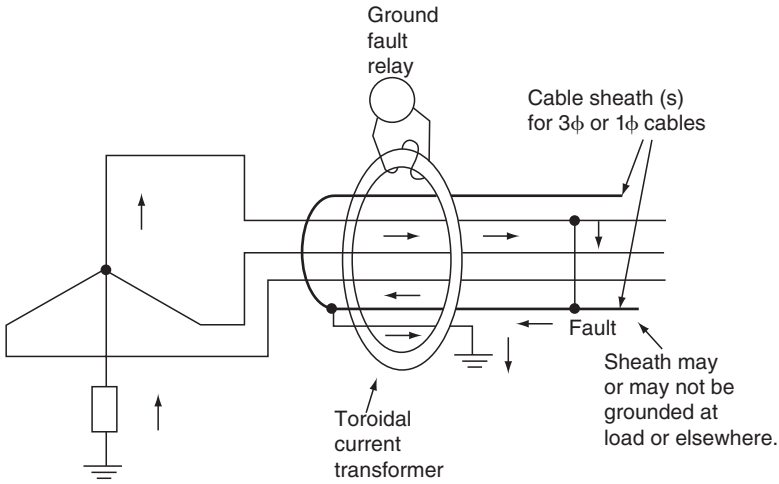

FIGURE 5.13 Typical application of the flux summation current transformer for ground-fault protection with metallic sheath conductors.

exciting current were negligible. Specific applications are discussed in later chapters.

A metallic sheath or shielded cables passed through the toroidal CT can result in cancellation of the fault current. This is illustrated in Figure 5.13. This applies either to three-phase cables, as shown, or to single-phase cables. The cancellation may be partial or complete, depending on the sheath grounding. This sheath component of fault current can be removed from passing through the CT by connecting a conductor, as shown.

5.10 CURRENT TRANSFORMER PERFORMANCE ON THE DC COMPONENT

As transformers are paralyzed by direct current, CT performance is affected significantly by the DC component of the AC current. When a current change occurs in the primary AC system, one or more of the three-phase currents will have some DC offset, although none may be maximum and one could not have much impact. This DC results from the necessity to satisfy two conflicting requirements that may occur: (1) in a highly inductive network of power systems, the current wave must be near maximum when the voltage wave is at or near zero and (2) the actual current at the time of change is that determined by the prior network conditions. For example, energizing a circuit with current zero, before closing the circuit at the instant when the voltage wave is zero presents a problem. By requirement (1) the current should be at or near maximum at that moment. Thus, a countercurrent is produced to provide the zero required by condition (2). This is the DC component equal and opposite

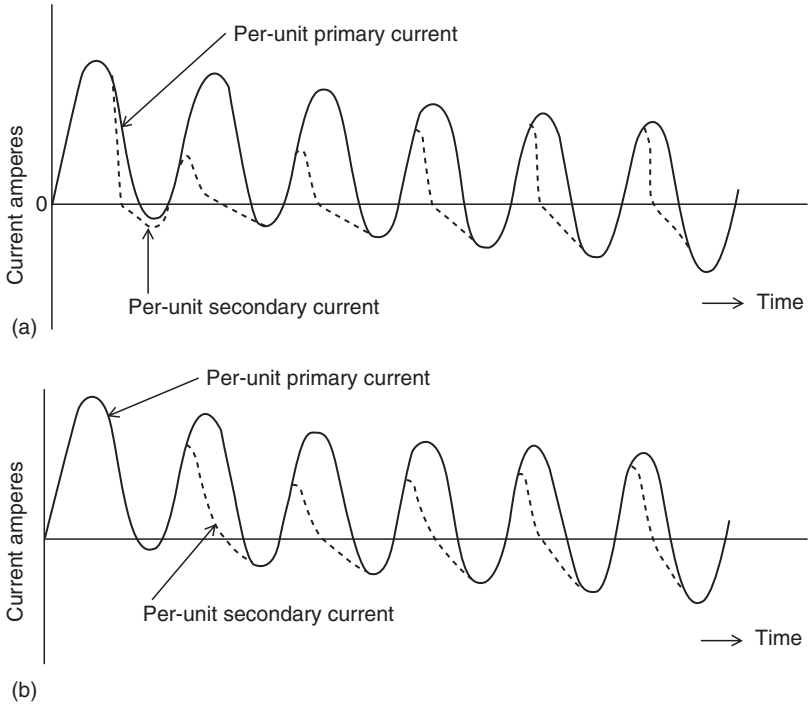

FIGURE 5.14 Typical possible distortion in CT secondary current resulting from DC saturation: (a) large resistive burden; (b) small resistive burden. (Figure 3 of IEEE 76-CH1130-4, *PWR Transient Response of Current Transformers*.)

to the required AC current by condition (1), with the two adding to zero at the instant of closing the circuit.

After having provided this function, the DC is no longer required, but it can disappear only by decaying according to the L/R time constant of the power system. This decaying DC acts more or less like a low-frequency alternating current in passing through the CT. It can saturate the iron such that the secondary reproduction of the primary current can be severely limited and distorted. This is illustrated in Figure 5.14 for a 20 times rated fully offset current with resistive burden. This type of burden causes a sharp drop-off of the secondary current during each cycle.

After saturation occurs, the decay of the DC component results in the CT recovering, so that during each subsequent cycle, the secondary current more nearly approaches the primary. As the DC disappears, the secondary is again a reproduction of the primary. This assumes no AC saturation. It is possible, but rarely occurs, that the secondary current may be practically zero for a few cycles in very severe cases.

Inductance in the burden results in a more gradual drop-off, whereas a lower burden reduces the distortion. These several effects are shown in [Figure 5.14](#). As shown, this saturation does not occur instantly; hence, initially, the secondary current follows the primary current, before it is reduced and distorted by saturation.

The time to saturate and the calculation of the secondary current are complex and depend on many factors: the nature of the fault current, the constants and design of the CT, and the burden connected. A simplified method for estimating the performance of ring-core CTs is available from the IEEE report *Transient Response of Current Transformers*. From a practical standpoint and as a general rule of thumb, the CTs used for relaying can be expected to reproduce, with reasonable accuracy, the primary current for about one-half cycle or more before a significant DC saturation.

5.11 SUMMARY: CURRENT TRANSFORMER PERFORMANCE EVALUATION

The following two types of CT saturation have been discussed.

5.11.1 SATURATION ON SYMMETRICAL AC CURRENT INPUT RESULTING FROM THE CT CHARACTERISTICS AND THE SECONDARY LOAD

[Figure 5.15](#) shows typical secondary voltages as a function of the secondary burden. There is always an output, although it may delay or be insufficient to operate relays. This saturation should be avoided, but this may not always be possible or practical.

Saturation on symmetrical AC is most critical at the point of relay decision. Thus, in differential protection, the decision point is at the CT nearest to an external fault. A fault on one side of the current transformer is internal, for which the protection must operate, but the fault on the other side is external, and the protection must not operate. This external fault is often very large and requires good CT performance. An AC saturation should not occur for this protection.

For overcurrent protection of lines, the decision point is remote from the CT and generally not so critical because time is involved in the relay operation; hence, some saturation can be tolerated. For heavy close-in faults, these relays may be operating on the relatively flat part of their time curve, for which magnitude differences are not critical. This also applies to close-in heavy faults for instantaneous or distance-type relays.

5.11.2 SATURATION BY THE DC OFFSET OF THE PRIMARY AC CURRENT

This is a function of the power system, and it is not practical to avoid its effect by the CT design. It will temporarily restrict the output of the CT, as

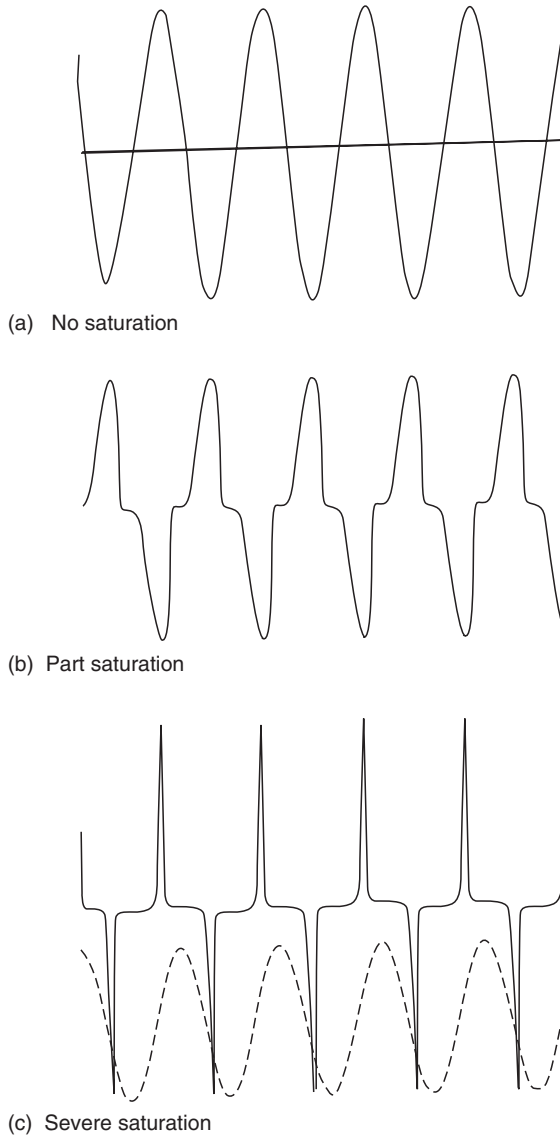

FIGURE 5.15 Typical secondary voltages of a current transformer with symmetrical AC current input and increasing secondary burden.

illustrated in [Figure 5.14](#), in contrast to the AC saturation of [Figure 5.15](#). This can be critical in differential protection where several CTs are involved in the fault determination. Differential relay designs use various techniques to prevent misoperation, generally keyed to no AC saturation.

In most other applications, DC saturation is not likely to be too severe, or to significantly inhibit the protection from a practical standpoint. However, it should always be considered and checked.

Most faults tend to occur near the maximum voltage, at which the prefault current is low in the inductive power system. This minimizes the DC offset; therefore, it is seldom at its maximum possible value. In many parts of the power system, the time constant will be short, such that when the DC offset occurs, it rapidly decays. Moreover, faults other than differential protection are not at the maximum value at the critical decision point of the protection.

For example, in line protection, the relay decision point is remote from the CTs; consequently, the fault current is often lower, and line resistance is available to help moderate the effect. In addition, the decision point may not be too critical, for time is often involved to clear remote faults. Generally, the close-in high-current faults will be greater than the relay pickup current, and with high-speed relays, operation may take place before DC CT saturation occurs. Should saturation occur before the line protection relays can operate, generally a delay in operation occurs until the CTs recover sufficiently to permit operation. Thus, the tendency for this type of protection usually is to “under-reach” momentarily, rather than “over-reach.”

5.12 CURRENT TRANSFORMER RESIDUAL FLUX AND SUBSIDENCE TRANSIENTS

When a CT is energized by a load for the first time, the excursion on the hysteresis loop is symmetrical, with a flux variation such as rr' in Figure 5.16. Faults with higher current produce increased flux and a wider excursion. When the fault is cleared and the primary current becomes zero, a unidirectional transient current can flow in the secondary. This is the trapped exciting current, which is out of phase with the fault primary–secondary current through the resistive-type burden before interruption. The time constant for this is usually short with resistive burdens, unless air gaps are employed in the CT core. This transient current may delay the dropout of very sensitive high-speed overcurrent relays used in breaker failure programmed in these schemes, particularly for HV system protection.

Interruption of the fault and the decay of I_e to zero still leaves flux in the CT. This is called residual flux, such as at point s in Figure 5.16. Now if the CT is reenergized with the original load current flowing, the flux excursion would resume, but from the residual flux level s with a loop ss' , where the flux variation of $ss' = rr'$. However, it cannot continue in loop ss' because this would require direct current to maintain it in this offset position. So it shifts down to a symmetrical position tt' , at which the variation $tt' = ss' = rr'$. During this shift, a small direct current flows in the secondary circuit, according to the burden secondary time constant. Until the load changes or another fault

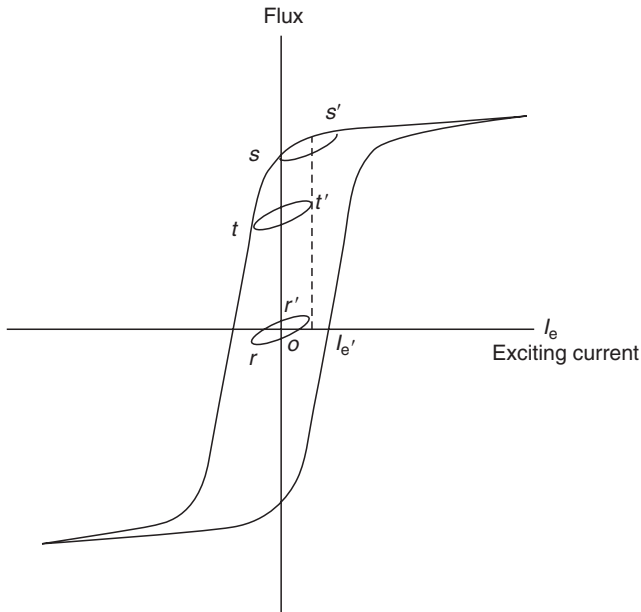

FIGURE 5.16 Typical hysteresis loops and residual flux in current transformers.

occurs, the flux will vary in this tt' loop indefinitely. If the circuit is opened to de-energize the primary current to zero, the residual flux would be the value existing at the moment of interruption and somewhere within loop tt' . Thus, CTs, once energized, will have residual flux anywhere between zero and the saturated value in either the positive or the negative loop.

For a later fault, the residual can either add or reduce the CT capabilities. In the example, residual flux points s and t are closer to the saturation level for flux excursions to the right, but are far away from saturation for excursions to the left. Consequently, the performance depends on which half cycle the next fault occurs. Because this is not predictable in theory, the residual flux can cause saturation and problems in protection. However, the general experience in the United States has not indicated this to be a serious problem. Very few cases have been cited in which this might have caused problems.

Air-gap CTs have been used to minimize this residual; however, their performance for general application is not nearly as reliable. Although they do not saturate as rapidly as the nongap designs, their exciting current is higher; there is a loss of steady-state accuracy and of transformation of the DC transient. The unidirectional CT current after a fault clears decays out more slowly with air gaps and so is more likely to cause problems in breaker failure relaying, as outlined earlier. Air-gap CTs still have minimal use in the United States.

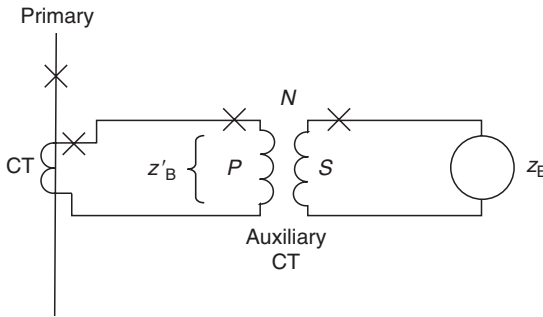

FIGURE 5.17 Auxiliary current transformers applied to change overall current transformer ratio.

5.13 AUXILIARY CURRENT TRANSFORMERS IN CT SECONDARY CIRCUITS

Auxiliary CTs are sometimes required to provide (1) different ratios than would otherwise be available, (2) phase shift in the current, or (3) circuit isolation. They should be used to step down the current to the burden whenever possible and to minimize the impedance loading on the main CT. This is illustrated in Figure 5.17. Z'_B is the impedance at the secondary of the main CT, which is the reflected impedance Z_B , or load connected to the auxiliary CT secondary. Neglecting the loss of the auxiliary CT yields

$$Z'_B = \frac{Z_B}{N^2}, \quad (5.6)$$

where N is the ratio of the auxiliary CT. Thus, for a step-down connection with the ratio $P:S$ of 10:5, $N = 2$ and $Z'_B = 0.25 Z_B$. However, with a step-up connection, where the ratio $P:S$ is 5:10, $Z'_B = 4.0 Z_B$. With high lead resistance, an auxiliary step-down CT near the main CT can be used to reduce this lead resistance load. The auxiliary CT does add its losses to the total load on the main CT.

5.14 VOLTAGE TRANSFORMERS FOR PROTECTIVE APPLICATIONS

VTs would have primaries that are either connected directly to the power system (VTs) or across a section of a capacitor string connected between phase and ground (CCVTs). Typical units are illustrated in Figure 5.3 through Figure 5.5, with connection schematics shown in Figure 5.18.

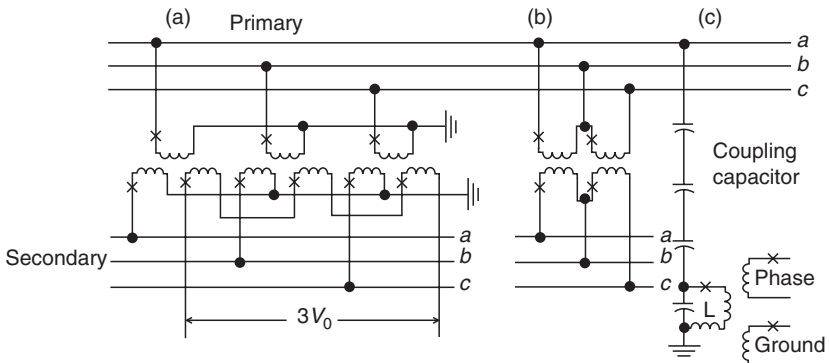

FIGURE 5.18 Typical voltage sources for relays: The secondary circuits for the coupling capacitor voltage transformer (CCVT) device are simplified schematics, for concept only. (a) secondary phase-and-ground voltage with three double secondary VTs connected phase-to-ground; (b) secondary phase voltage with two single secondary VTs connected open delta; (c) secondary phase-and-ground voltage with three CCVTs connected phase-to-ground. [Only one phase shown, *b* and *c* phases duplicate with secondaries connected as in (a).]

Protective relays utilizing voltage are usually connected phase-to-phase, so the transformers are normally rated 120 V line-to-line. Taps may be provided to obtain either 69.3 V or 120 V line-to-neutral. When available, double secondaries provide the means of obtaining zero-sequence voltage for ground relays (see Figure 5.18a). If only a single transformer secondary winding is available, an auxiliary wye ground-broken delta auxiliary VT can be connected to the secondary *a*, *b*, and *c* bus of Figure 5.18a for $3V_0$, similar to the connections shown in Figure 1.10. CCVTs commonly have double secondaries for both phase and $3V_0$ voltages (see Figure 5.18c).

Three VTs or three CCVTs, such as shown in Figure 5.18a and c, pass positive-, negative-, and zero-sequence voltage. The open-delta connection of Figure 5.18b will pass both positive- and negative-sequence voltage, but not zero-sequence voltage.

VTs are used at all power system voltages and are usually connected to the bus. At about 115 kV, the CCVT type becomes applicable and generally more economical than VTs at the higher voltages. Usually, the CCVTs are connected to the line, rather than to the bus, because the coupling capacitor device may also be used as a means of coupling radio frequencies to the line for use in pilot relaying. This is discussed in Chapter 13.

Either type of transformer provides excellent reproduction of primary voltage, both transient and steady-state, for protection functions. Saturation is not a problem because power systems should not be operated above normal voltage, and faults result in a collapse or reduction in voltage. Both have ample capacity

and are highly reliable devices. VTs are normally installed with primary fuses that are not necessary with CCVTs. Fuses are also used in the secondary. A common practice is to use separate secondary fusing for voltage supply to different groups of relays used in the total protection. Fuses are a hazard. A loss of potential by a fuse may result in unwanted, incorrect relay operations. In some cases, overcurrent fault detectors are used to minimize this possibility.

Some CCVTs may exhibit a subsidence transient when the system voltage is suddenly reduced, such that the secondary voltage is not a replica of the primary, momentarily. This is caused by the trapped energy ringing in the secondary compensating or turning reaction (L) and the associated circuit. This transient can be at a different frequency from that of the system frequency, or unidirectional. This has not been a problem for electromechanical relays, but it may cause problems for solid-state types. Modern-design CCVTs are available to eliminate this problem.

5.15 OPTICAL SENSORS

As previously illustrated, classical magnetic CTs are subject to various problems for certain conditions. These problems require special attention when such CTs are applied and sometime require that lesser than the desired performance be accepted. As noted earlier in this chapter, an alternative that has been receiving increased attention in recent years is the use of optical CTs. Such devices eliminate most of the serious problems that are associated with iron-core magnetic CTs. Optical CTs offer increased accuracy, reduced size, and wider bandwidth. Optical CTs are also safer to work with than conventional CTs. When the secondary circuit of a conventional CT is opened while the primary current is flowing, very high voltages can be developed at the location of the opening. These voltages can be damaging to the equipment and a safety hazard to the personnel working in the area. Panel boards have been completely destroyed when CT secondary circuits had been inadvertently opened. Test personnel must take special precaution when working on CT secondary circuits which can be time consuming or dangerous if an error occurs. This is not a problem when dealing with optical CTs. Reasons do exist, however, for the slow utilization rate of optical CTs that has been experienced in the industry till recent. For one, such application requires users to become familiar with a new technology. Utilities are typically hesitant to convert to new technologies due to the learning curve involved, requirements for new test equipment and methods, and risks associated with trying something new. Additionally, relays and metering must be capable of accepting the digital or low-level analog signals that are provided by optical CTs. This has generally limited the use of such CTs to new installations or in cases where conditions exist that cause severe application problems for conventional type CTs.

The term “optical sensing” can sometimes be confusing, in that it is sometimes used to describe systems that use conventional iron-core sensing devices, with its output converted to an optical signal for transmission to the protection, control, and metering devices. True optical sensors do not use iron-core devices, but use optical materials and fundamentally different techniques to measure current. True optical sensors can be classified as bulk optics or pure fiber optics. Bulk sensors use a block of glass machined to direct light around the conductor. Such sensors are limited in ability to adapt to various sizes and shapes. Pure fiber sensors are constructed by wrapping fiber around the conductor. Various physical sizes and shapes are possible with a pure fiber design. Optical current sensors can be further classified as polarimetric and interferometric sensors. These terms identify the method used to manipulate light waves to enable a measurement of current flow in the conductor. An analysis of these measuring techniques is beyond the scope of this book. A good reference on this subject is a paper entitled “Current transformer errors and transformer inrush as measured by magnetic, optical, and other unconventional CTs” by John Horak and James Hrabliuk. This reference also provides insights into requirements for interfacing optical sensors with protective relays.

It is obvious that optical sensors provide significant operational advantages over conventional CTs and will probably receive greater utilization as protective systems are converted to digital devices, fault current levels continue to increase on power systems, costs are reduced, and engineers become more familiar and confident with the technology. Besides, the advantages associated with accuracy and freedom from saturation, the fundamental characteristics of such measuring systems can be changed by simple program changes in the associated software. Moreover, availability of the measured quantities in digital form can serve to simplify tasks related to design, testing, and diagnostics. Optically based measuring devices have the potential to revolutionize the manner in which measurements are made in power systems.

BIBLIOGRAPHY

- ANSI/IEEE Standard C57.13.1, Guide for Field Testing of Relaying Current Transformers, IEEE Service Center.
- ANSI/IEEE Standard C57.13.2, Guide for Standard Conformance Test Procedures for Instrument Transformers, IEEE Service Center.
- ANSI/IEEE Standard C57.13.3, Guide for the Grounding of Instrument Transformer Secondary Circuits and Cases, IEEE Service Center.
- ANSI/IEEE Standard C57.13.8, Requirements for Instrument Transformers, IEEE Service Center.

- Connor, E.E., Wentz, E.C., and Allen, D.W., Methods for estimating transient performance of practical current transformers for relaying, *IEEE Trans. Power Appar. Syst.*, PAS 94, January 1975, pp. 116–122.
- Iwanusiw, O.W., Remnant flux in current transformers, *Ontario Hydro Res. Q.*, 1970, pp. 18–21.
- Linders, J.R. and Barnett, C.W., Chairman, relay performance with low-ratio CTs and high fault currents, *IEEE Trans. Ind. Appl.* 1995, 31, pp. 392–404.
- Transient response of coupling capacitor voltage transformers, IEEE Power System Relaying Committee Report, *IEEE Trans. Power. Syst.*, PAS 100, December 1981, pp. 4811–4814.
- Transient response of current transformers, Power System Relaying Committee Report 76-CH1130-4 PWR, IEEE Special Publication. A summary report and discussion, *IEEE Trans. Power Appar. Syst.*, PAS 96, November–December 1977, pp. 1809–1814.
- Wentz, E.C. and Allen, D.W., Help for the relay engineer in dealing with transient currents, *IEEE Trans. Power Appar. Syst.*, PAS 101, March 1982, pp. 517–525.

6 Protection Fundamentals and Basic Design Principles

6.1 INTRODUCTION

The best protection technique now and for more than 50 years is that known as differential protection. Here the electrical quantities entering and leaving the protected zone or area are compared by current transformers (CTs). If the net between all the various circuits is zero, it is assumed that no fault or intolerable problem exists. However, if the net is not zero, an internal problem exists and the difference current can operate the associated relays. In general, internal faults provide significant operating current, even for fairly light faults.

Differential protection is universally applicable to all parts of the power system: generators, motors, buses, transformers, lines, capacitors, reactors, and sometimes a combination of these. Since the protection of each part of the power system is discussed, invariably, differential protection is the first consideration, and often it is the choice for the primary protection.

6.2 DIFFERENTIAL PRINCIPLE

This fundamental technique is illustrated in [Figure 6.1](#), and for simplicity, only two circuits in the protection zone are shown. Multiple circuits may exist, but the principle is the same. The sum of the currents flowing in essentially equals the sum of the currents flowing out during normal operation. The voltage differential system is similar and is discussed in [Chapter 10](#).

For normal operation and all external faults (the through condition), the secondary current in [Figure 6.1a](#) in the protective relay is the difference in the exciting currents of the differentially connected current transformers. Per-unit current distribution is also shown in the figure. For example, I_p is the primary current in the lines entering or leaving the protected area. $I_p - I_e$ is the secondary ampere current and is equal to the primary current divided by the current transformer ratio minus the secondary exciting current. Even with exactly the same ratio and type of current transformer, the relay current I_{OP}

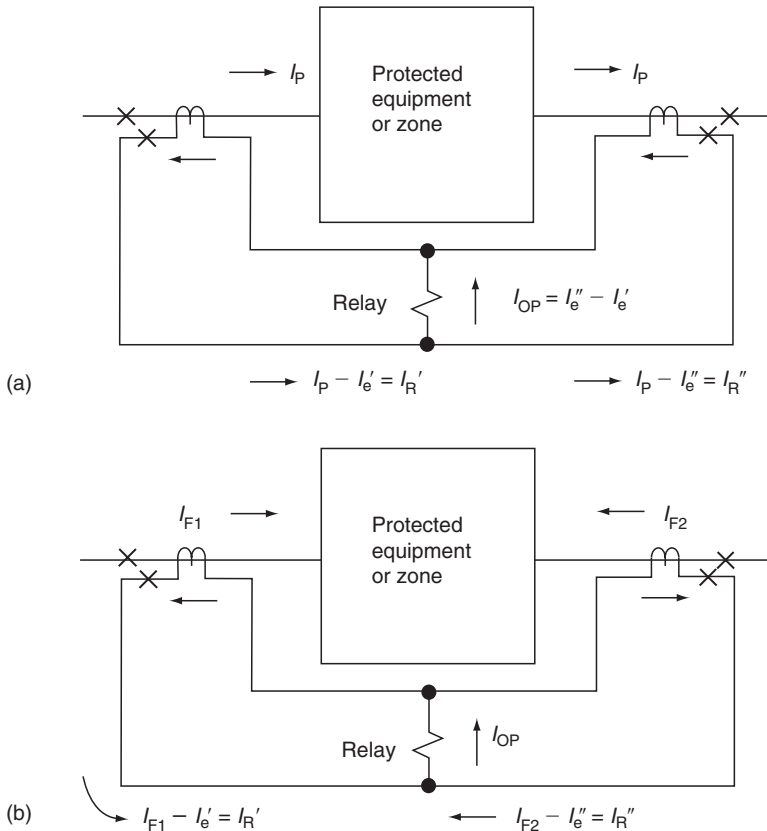

FIGURE 6.1 Basic current differential scheme illustrated for the protection of a zone with two circuits: (a) normal conditions, $I_{OP} = I_e'' - I_e'$; (b) internal fault $I_{OP} = I_{F1} + I_{F2} - (I_e' + I_e'')$.

will be small, but never zero. This is because of the losses within the protected area and small differences between the same CTs. This assumes that no current transformer significantly saturates for the maximum symmetrical ac through currents. With different CTs and ratios, larger differences will exist that must be minimized or the pickup of the relay must be set so that it does not operate on any through condition.

During external faults the transient performance of the several CTs resulting from the sudden increase in current and the associated offset (DC component) can produce rather large transient-operating currents. Thus, it is difficult and impractical to apply an instantaneous relay. Time-delay relays can be used with care.

For internal faults, Figure 6.1b shows that the differential relay operating current is essentially the sum of the input currents feeding the fault. This is the

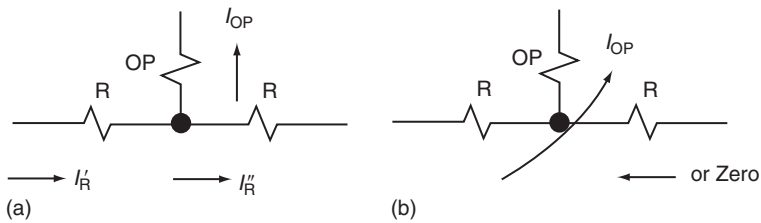

FIGURE 6.2 Percentage differential relay: (a) external faults; (b) internal faults.

total fault current on a secondary ampere basis. Except for very light internal faults, good discrimination is available to detect problems (faults) within the differential zone. For the differential relay to operate, it is not necessary for all the circuits to supply fault current if no current is supplied to the fault.

To provide high sensitivity to light internal faults with high security (high restraint) for external faults, most differential relays are of the percentage differential type. Figure 6.2 is a simplified schematic of this type of relay for two circuits, as shown in Figure 6.1. The secondary of the CTs are connected to restraint windings R and currents in these inhibit operation. Associated with these restraint windings is the operating winding OP . Current in this winding tends to operate the relay. Differential relays may be either fixed or variable that tends to operate the relay. These may be of either fixed or variable percentage, and typical characteristics are illustrated in Figure 6.3. The abscissa is the restraint current. This can be either the smaller current (I'_R) or the larger current (I''_R) depending on the design. The ordinate is the current (I_{OP}) required to operate the relay. Fixed percentage relays exist between 10% and 50% and may or may not have taps to change the percentage.

Thus with a 50% characteristic, an external or through current of 10 A would require a difference or operating current of 5 A or more for the relay to

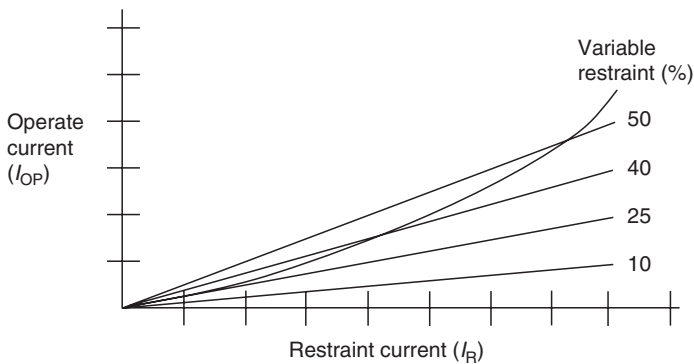

FIGURE 6.3 Typical through current characteristics of various differential-type relays.

operate. With a 10% type, and 10 A through current, 1 A or more difference current would produce relay operation.

The variable percentage types do not have percentage taps. At low through currents the percentage is low because at these levels the current transformer performance is usually quite reliable. At high through-fault currents, where the CT performance may not be as dependable, a high-percentage characteristic is provided. This gives increased sensitivity with higher security.

It is important to recognize that characteristics, such as those shown in [Figure 6.3](#), apply only to external faults or through current flow. Differential relays are quite sensitive to internal faults when the currents in the restraint windings are in opposite directions or one of the restraint current is zero, as in [Figure 6.2](#). These relays are calibrated with current through one restraint and the operating windings with no current through the other restraint(s). Typical pickup currents for differential relays are of the order of 0.14–3.0 A, depending on the type, tap, and application.

As it has been seen, the differential principle compares the outputs of the current transformers in all the circuits in and out of the protected area or zone. For equipments, such as generators, buses, transformers, motors, and so on, the CTs usually are all in the same general area, so that it is not too difficult to interconnect their secondaries with the relays. For lines where the terminals and CTs are separated by considerable distances, it is not practically possible to use differential relays as described earlier. Yet, the differential principle provides the best protection and is still widely used. This is true particularly at the higher voltages. A communication channel, such as a pilot wire (wire or fiber-optic cable), power line carrier (radio frequency), audio tones over wire, or microwave is used for information comparison between the various terminals. These systems are discussed later.

6.3 OVERCURRENT-DISTANCE PROTECTION AND THE BASIC PROTECTION PROBLEM

When the differential is not used, overcurrent or distance relays are the major protection possibilities. Because faults produce an increase in the phase or ground, or both, overcurrent protection is widely applied at all voltage levels for the currents in the system. Distance relays operating on the increase in current and decrease in voltage are used principally at the higher-voltage levels.

The minimum-operating criteria for overcurrent relays are shown in [Figure 6.4](#). These relays may operate instantaneously; with fixed or inverse time delays (see [Figure 6.7](#)). The techniques for applying and setting these relays for the protection of equipment in the power system are discussed in the later chapters.

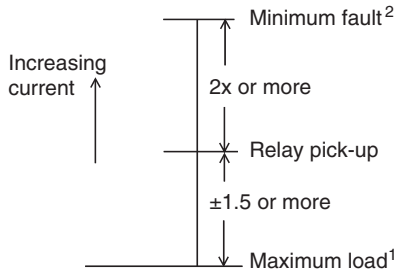

¹For phase relays
 Max. short time load (asymmetrical offset, magnetizing inrush, cold load, unusual operation).
 For ground relays
 Max. zero sequence unbalance, phase phase-to-ground (neutral) loads.

²Nominally $I_{3\phi}$ for phase faults,
 $I_{\phi\phi} = 0.866 I_{3\phi}$.
 or $3I_0$ for ground faults,

FIGURE 6.4 Criteria for selecting overcurrent relay taps.

The operation of overcurrent and distance relays at the border of a protection zone is not as precise as for differential protection. Hence, they may either underreach or overreach for faults near this border. Thus, this situation becomes a protection problem. This is illustrated in Figure 6.5.

The relays at station G for the protection of the line GH should operate fast for all faults in the area between the two line terminals. This is the

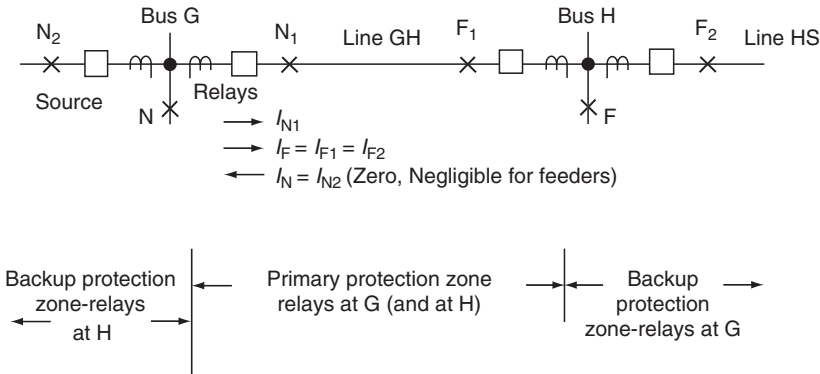

FIGURE 6.5 Protection problem for protective relays at station G for line GH.

primary protection zone for the relays at G and at H. Fault F_1 is in this primary zone, but faults F and F_2 are external and should be cleared by other protection. However, for the relays at G, the currents are the same, since the distances between these three faults are very small and negligible. Thus, practically, $I_F = I_{F_1} = I_{F_2}$. Therefore, the relays at G cannot determine by current (or voltage) magnitude, if the remote fault is at F_1 , where desirably, they should operate fast, or at F or F_2 , where they should delay. Hence, the problem is to distinguish the internal fault F_1 from the external faults F and F_2 . There are two possible solutions: (1) time or (2) communication.

6.3.1 TIME SOLUTION

The time solution delays the operation of the relays at G for the faults near or at the bus H. This delay is to permit the primary relays for the bus H and the line(s) to the right of H to clear the faults, such as F and F_2 . Unfortunately, this indicates that the internal faults on line GH near the bus H, such as F_1 , will be delayed.

Setting the relays, phase or ground, for this time solution is called *coordination* or *selectivity*. Basically, this technique attempts to set the primary relays to provide fast operation for close-in faults (N_1), yet to delay, for coordination with the relays at H, for faults at or near the bus H. This is accomplished with inverted time–overcurrent relays, in which the operating time increases as the current magnitude decreases, or with instantaneous relays and constant (fixed) time delays. Coordination is discussed in more depth later, particularly when we discuss line protection in [Chapter 12](#).

6.3.2 COMMUNICATION SOLUTION

The second, a communication solution is a type of differential protection, as outlined earlier. The relays at H for the protection of line GH indicated by the direction of the power flow or the relative phase angle information whether the fault is internal (F_1) or external (F and F_2). This information is communicated by a channel to the relays at G. Similarly, the relays at G provide information that is communicated to H. If the fault is in the primary zone (faults N_1 to F_1), both G and H operate together at high speed. For the external faults (on the bus at G or H, to the left of G, and to the right of H), the relays at both G and H do not operate. This is an elementary introduction to pilot relaying, which is discussed in detail in the subsequent chapters.

6.4 BACKUP PROTECTION: REMOTE VS. LOCAL

The importance of backup and redundancy in system protection has been indicated in [Chapter 1](#) and is discussed again in [Chapter 8](#) through [Chapter 13](#).

Backup is defined as “protection that operates independently of specified components in the primary protective system.” It may duplicate the primary protection, or may be intended to operate only if the primary protection fails or is temporarily out of service (IEEE 100). The various types can be illustrated with reference to the protection at station G for the line GH of Figure 6.5. Relays applied at G, as shown, primarily provide primary protection to the line GH. For faults in the line, generally more than one of the several primary relays may operate. This provides primary backup through redundancy. For very important circuits or equipment, especially at HV and EHV levels, completely separate protection, operating from different CTs (and sometimes different VTs), separate DC supplies and operating different trip circuits on the breakers are commonly used. One protective system is designated as the primary one, and the other as secondary—more or less of a misnomer, for usually they operate together at high speed.

In the simple two-line system of Figure 6.5, it was seen that the relays at G must be set to operate for the external faults F , F_2 and others out on line HS to provide protection to fault F_1 . Thus, relays G provide primary protection to line GH, and backup protection for bus H and line HS. This is a remote backup. If the F , F_2 , and other faults are cleared by their primary relays and associated circuit breaker(s), relays at G should operate and remove the G source from the fault. Similarly, all other sources supplying current to the uncleared fault should be cleared by the backup operation of the relays at their remote terminals.

In recent years, it has been desirable to have a backup protection at the local station and to open all the breakers around the bus, rather than at the remote terminals. This is the local backup, also associated with breaker failure. In this type of application, the breaker at H on line GH, rather than the breaker at G would be relayed to clear faults F_2 and so on, if the primary relays or the H breaker on line HS fail to operate.

For local backup there should be a separate, independent set of relays, which always exists for remote backup. This is available with the independent primary and secondary relay systems, as indicated earlier, which is applied principally at high voltages. This independence may not exist in low-voltage protection systems. If this independence is not provided, there is the possibility that a failure in the protection will prevent the opening of the local breakers to clear the fault. Clearing the fault under these circumstances could be achieved only by remote backup.

6.5 BASIC DESIGN PRINCIPLES

The design techniques used to provide relays for the protection of electric power systems have progressed from electromechanical to solid state in a relatively short period. Several steps involved in this progress are as follows:

1. *Electromechanical*: all analog measurements, comparisons, tripping, and so forth
2. *Solid state*: analog or operational amplifiers, solid-state operate element, thyristor, or contact output
3. *Hybrid*: analog, with microprocessor logic, timing, and such, contact output
4. *Numerical*: analog/digital and microprocessor, contact output.

All types are in service, but currently the microprocessor designs are widely offered. Many electromechanical relays are still providing good protection around the world.

The basic protection characteristics are essentially the same for both electromechanical and solid-state relays. Thus, a review of these for the electromechanical relays provides a base for the modern units. Most of the basic characteristics were established around 60 years ago.

6.5.1 TIME-OVERCURRENT RELAYS

The time-overcurrent type relay, one of the first protective relays, developed around 60–70 years ago, is still widely used in many applications throughout the power system. Originally, it was basically a watt-hour meter with contacts and restricted disk travel. Now, as it has been for many years, the design is entirely different, except that it uses the fundamental induction disk principle. One typical type is illustrated in [Figure 6.6](#). Alternating current or voltage applied to the main coil produces magnetic flux, most of which passes through the air gap and disk to the magnetic keeper. This returns through the disk to the two side legs of the electromagnet. The shorted turns of the lag coil on one side leg cause a time and phase shift in the flux through that side of the disk to produce rotation of the disk. This rotation is damped by a permanent magnet. The spiral spring provides reset of the contacts after the operating quantity is removed or reduced below the pickup value. Contacts attached to the disk shaft can normally be open or closed in the de-energized state. This combination produces fast operation at high current and slow operation at light current; hence, an inverse time characteristic. Over the years various shapes of time curves have evolved, which are shown in [Figure 6.7](#) for general comparison. Solid-state versions of these relays are available that essentially duplicate these curves and general characteristics, with lower burdens, wider application ranges, and adjustable time characteristics.

All relays have several taps, each of which represents the minimum current (or voltage) at which the unit will start to operate. This is the minimum pickup value. Thus, a current relay set on tap 2 will begin to operate at 2.0 A, plus or minus the manufacturer's tolerances. At this current, the time will be very long and difficult to check unless the current is maintained at an extremely accurate value. Any small or transient deviation at this

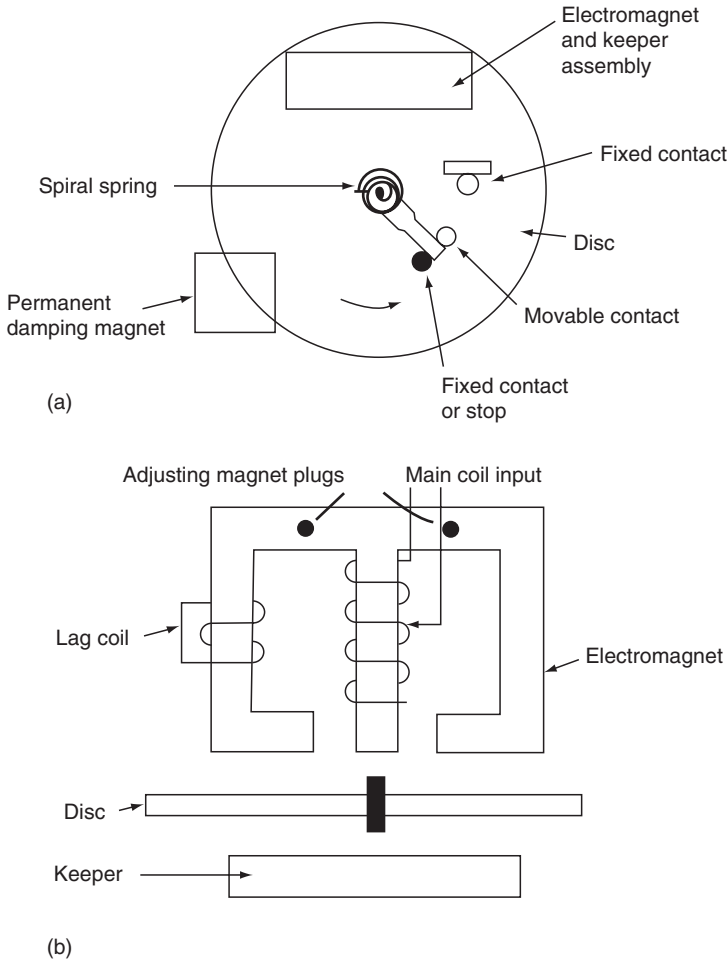

FIGURE 6.6 Typical induction disk inverse-type-overcurrent or voltage relay: (a) top view; (b) side view.

level will result in a significant time change. Hence, manufacturers generally do not show their time curves below 1.5–2 times minimum pickup. Practically, this is not a usable part of the curve for protection.

The abscissa of the characteristic curves is shown in multiples of tap or pickup current. This is for the convenience of providing one scale for all taps. For example, with tap 5, a multiple of 5 on the curve represents 25 A, with tap 2, the multiple represents 10 A, and so on.

In addition to the taps, the spacing for the contact travel is adjustable and marked by a scale, known originally as a “time lever” and currently as a “time dial.” This provides different operating times at the same operating

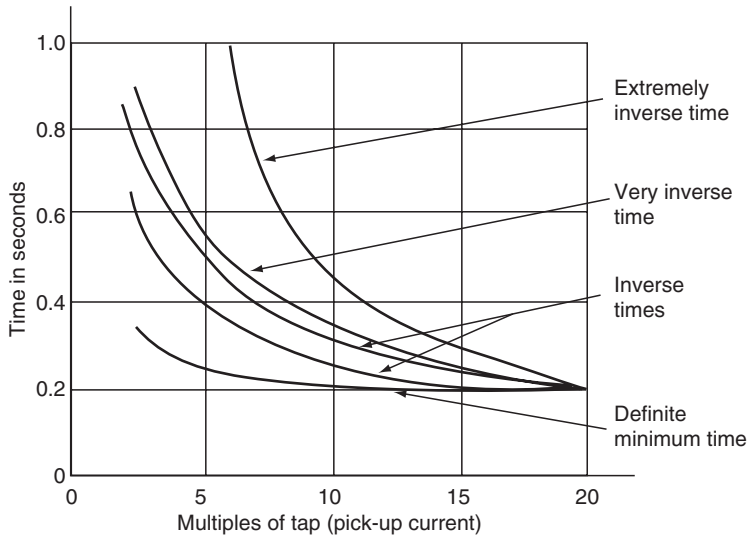

FIGURE 6.7 Typical inverse-time-overcurrent relay characteristics. For general comparison, the curves are fixed at 0.2 sec at 20 times minimum pickup current.

current level, a family of curves not illustrated in Figure 6.7. Thus, for each relay type, typical time-current characteristic curves are available, usually with curves from half through 11 time-dial settings. These are available on semilog or on log-log fuse-type coordinate paper.

These relays have over-travel and reset times, which can be important for some applications. Overtravel in the electromechanical units is the travel of the contacts after the current drops below the pickup value. Typical values are of the order of 0.03–0.06 sec, generally negligible in most applications. Reset time can be important in coordination with fast-reclosing or fast-repetitive faults. It is a function of the time-dial setting and the design. Data on reset are available from the manufacturers. The values are generally negligible for solid-state types. Fast reset may not be advantageous when coordinating with fuses and relays that do not have fast-reset characteristics.

In a protective relay, the opening of the circuit breaker generally reduces the current through the relay to zero. This may not be true when a relay is used as a fault detector and set to operate for faults well beyond the primary protection zone. Most induction disk time-overcurrent relays will not start to reset until the current drops below about 60% of the pickup current.

The relays described earlier are nondirectional; that is, they can operate independent of the direction of the current. If this is not desired, a separate directional element, such as that discussed in [Chapter 3](#), is used. The induction disk unit provides rotational torque by lag loops on the electromagnet to provide a flux shift. “Torque control” varieties have this lag circuit

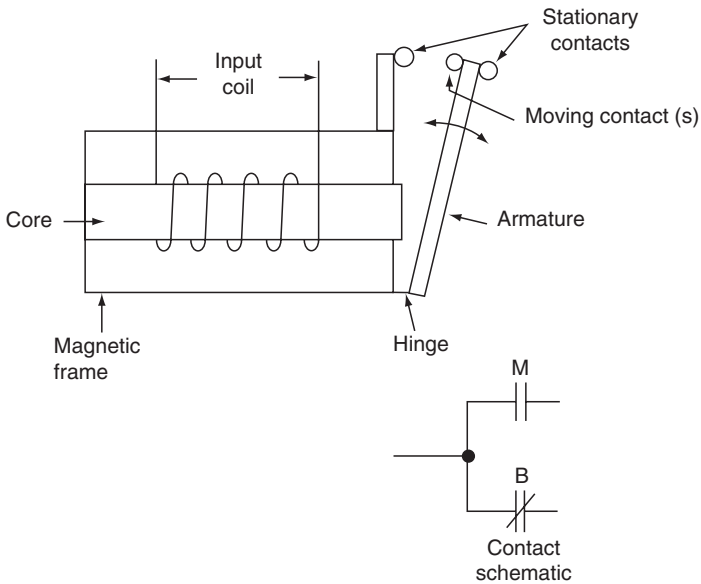

FIGURE 6.8 Typical electromechanical clapper or telephone relay.

available for external use, or the directional unit contacts or output are internally connected in this circuit. As long as the lag coil or its equivalent is open, no amount of current can cause operation. When the directional unit closes the circuit to the lag coil or equivalent, operation is as in the characteristic curves. This is directional torque control. The induction disk unit and its solid-state equivalent are used for overcurrent, overvoltage, undervoltage, combined over- and undervoltage, and power, as well as in other types of designs.

6.5.2 INSTANTANEOUS CURRENT–VOLTAGE RELAYS

Such relays are used in many areas of protection, such as overcurrent or over- or undervoltage units, to trip directly, or as fault detectors for security. Typical types in general use are the clapper or telephone relay (Figure 6.8), solenoid or plunger relay (Figure 6.9), and induction cup or induction cylinder relay (Figure 6.10).

The term “telephone” relay dates from its very wide application in telephone exchange systems. Now, this use has been superseded by modern solid-state electronic switching. However, relays of this type are still used in many auxiliary applications, both in ac and in DC. It is a common output relay for many solid-state protective relays.

An example of the solenoid type as a DC type is its use as a seal-in contact switch (CS) in Figure 1.9. With an ac coil and constructions, the solenoid unit

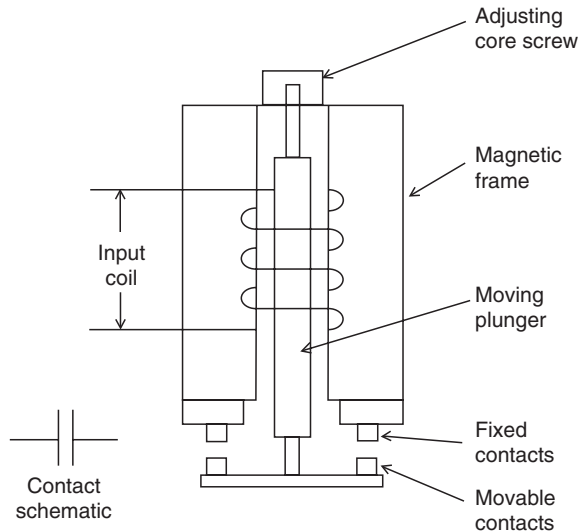

FIGURE 6.9 Typical electromechanical plunger relay.

serves as an instantaneous trip unit (IT and IIT). The operation of the first two is basic; current or voltage applied to the coil produces flux, which attracts the armature or plunger. Contacts on the moving member are thus operated. Multiple contacts are possible, especially on the telephone types.

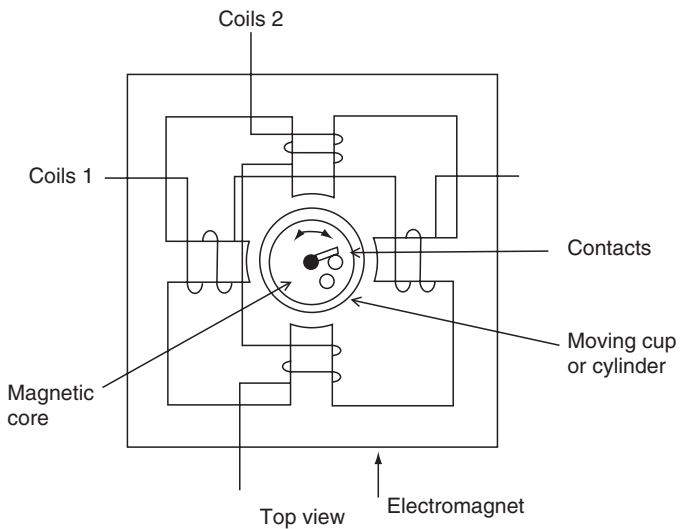

FIGURE 6.10 Typical electromechanical induction cup or cylinder relay.

The ac types have taps or other means to change the pickup value. For trip service, dropout is seldom a problem, and many of these units do not drop out after closing their contacts, after operation, until the current (voltage) drops to the order of 60% of the pickup value. Where this is a problem, high-dropout models of [Figure 6.9](#) type are available. These will reset at 90% of the pickup value or higher. In general, fault detectors should be of the high-dropout type.

The AC induction cup or induction cylinder unit of [Figure 6.10](#) is basically a “two-phase motor,” with the two coils wound as shown on the four poles of the electromagnet. In the center is a magnetic core; around or over this is the moving cup or cylinder, with the moving contacts and spring to provide reset. When the fluxes of coils one and two are in phase, no rotational torque exists. As an instantaneous overcurrent unit, a phase shift is designed in one coil circuit, such that an operating torque is produced when the current is higher than the pickup value. The rotation is limited to a few millimeters, enough to close the contacts. Typical times of operation are about 16–20 msec.

6.5.3 DIRECTIONAL-SENSING POWER RELAYS

The induction cup and induction cylinder units are used to indicate the direction of power flow and magnitude. This first application for directional sensing was discussed in [Chapter 3](#). Typical characteristics are shown in [Figure 3.7](#). The operating current is passed through one set of windings and a reference voltage or current through the other. When the phase relations are as indicated, the unit operates. Because these units, as directional units, are very sensitive, they are used in almost all applications with fault-sensing units, such as the time–overcurrent or instantaneous overcurrent units discussed earlier. Other types have tapped windings to operate when the power level exceeds a preset value.

6.5.4 POLAR UNIT

The polar unit is a DC unit operating from ac quantities through a full wave-rectifier. It provides very sensitive, high-speed operation, with very low-level inputs. As shown in [Figure 6.11](#), an electric coil is wound around a hinged armature with contacts in the center of a magnetic structure with nonmagnetic spacers at the rear. A permanent magnet bridges this structure to polarize the two halves. Two adjustable magnetic shunts bridge the spacers to vary the magnetic flux paths.

With the coil deenergized and balanced air gaps (see [Figure 6.11a](#)), the armature is not polarized, and contacts will float in the center. Now, adjusting the gaps to provide unbalance, some of the flux is shunted through the armature (see [Figure 6.11b](#)). Thus the contacts can be held either opened or closed.

Energizing the coil with DC magnetizes the armature either north or south, thereby increasing or decreasing any prior armature polarization. In

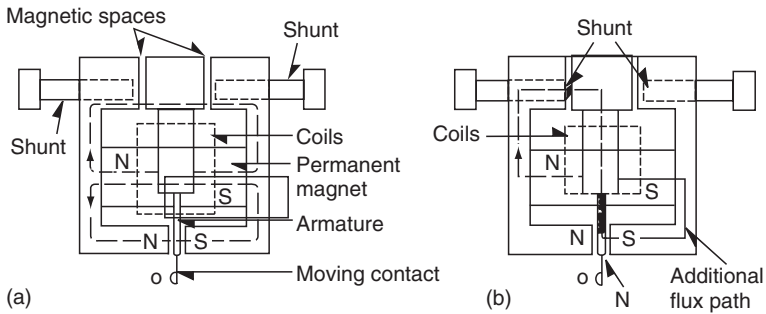

FIGURE 6.11 The DC polar unit: (a) balanced air gaps coil deenergized; (b) unbalanced air gaps coil deenergized.

Figure 6.11b the armature is shown as polarized N before energization so the armature moves to the right and the contacts open. Direct current in the coil, to overcome prior polarization and to make the contact end at the south pole, results in contact movement to the left and contact closure. The contact action can be gradual or quick, depending on the adjustments. The left gap controls the pickup value, and the right gap the reset value.

Two coils, an operating coil and a restraint coil, are used in some applications. An example is the electromechanical pilot wire relay (see Figure 13.4).

6.5.5 PHASE DISTANCE RELAYS

Fundamentally, distance relays compare the power system voltage and current. They operate when the ratio is less than its preset value. For balanced conditions and for phase faults, the ratio of the voltage to current applied to the relay is the impedance of the circuit, because $V/I = Z$. Thus, these relays are set as a function of the fixed impedance of the power system for the zone they are to protect.

6.5.5.1 Balanced Beam Type: Impedance Characteristic

An earlier design (no longer manufactured) provides a good basic understanding of the principle and appreciation of common terms that are currently used. This early type is illustrated in Figure 6.12. A balanced beam has a voltage-energized electromagnet to restrain its movement and a current-operated electromagnet to close its contacts. By design and setting, the voltage-restraint force can be made to equal the current-operating force for a solid zero-voltage three-phase fault at the set point shown as nZ_L . This threshold point is known as the “balance point,” “operating threshold,” or “decision point” of the unit. For a fault between the relay and the point n , the current I

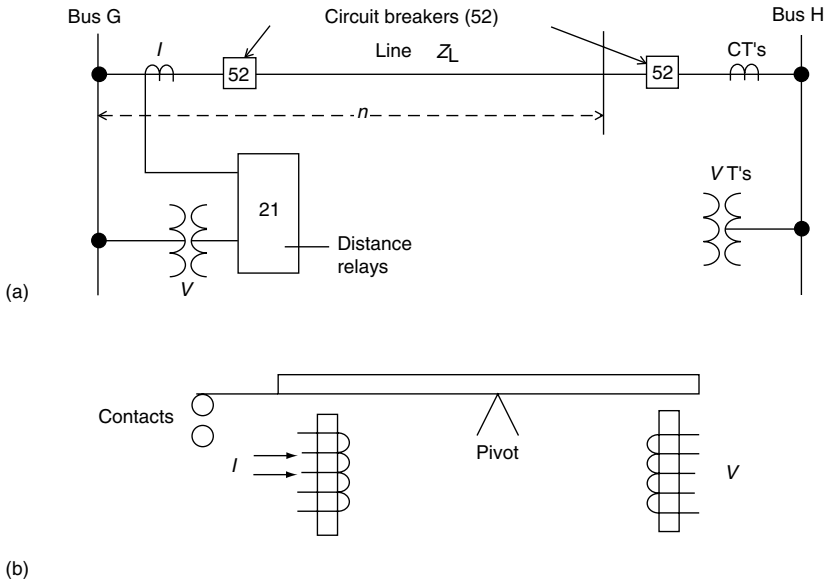

FIGURE 6.12 Distance relay-operating principles explained fundamentally by the balanced beam impedance unit: (a) distance relay to line GH; (b) simplified explanation diagram with a beam unit.

will be larger and V will decrease or remain approximately the same, relative to the value for the fault at n . Thus, the increased current causes the beam to tip at the left end to close the contacts.

For an external fault to the right of point n , the current will be less than for the fault at n , and the voltage will be higher. Thus, the torque or pull of the voltage coil is greater than that of the current coil for restraint or no operation.

With the solid three-phase fault at the balance point n , the voltage at n will be zero. Then the voltage at the relay location will be the drop along the circuit, or InZ_L . Dividing this voltage by the current, the unit responds to impedance:

$$Z_R = \frac{V}{I} = \frac{InZ_L}{I} = nZ_L. \tag{6.1}$$

Thus, the setting and operation are a function of the impedance from the relay voltage measurement point to the balance or set point.

Lewis and Tippett (1932), in their classic paper, showed that by using line-to-line voltages and line-to-line currents the reach of phase-type relays is the same for three-phase, phase-to-phase, and two-phase-to-ground faults. Because the current values get cancelled in Equation 6.1, this reach is fixed

for a given setting over a very wide range of fault currents, thereby providing a fixed reach, instantaneous protective relays not possible with an overcurrent instantaneous relay.

6.5.6 R–X DIAGRAM

The characteristics of distance relays are shown most conveniently in an impedance R – X diagram, where the resistance R is the abscissa and the reactance X is the ordinate. Typical characteristics on these axes are shown in Figure 6.13. For any given discussion the origin is the relay location, with the operating area generally in the first quadrant. Whenever the ratio of the system voltage and current fall within the circle shown, or in the cross-hatched area, the unit operates.

The elementary type discussed in Figure 6.12 provided an impedance characteristic such as that shown in Figure 6.13a. This obsolete design was independent of the phase relation of the voltage and current, thereby operating in all the four quadrants. Thus, a separate directional-sensing unit was necessary to prevent operation for faults in the system to the left of bus G (see Figure 6.13a).

6.5.7 MHO CHARACTERISTIC

The circle through the origin (see Figure 6.13b) is known as an mho unit and is in wide use for line protection. It is directional and more sensitive to fault

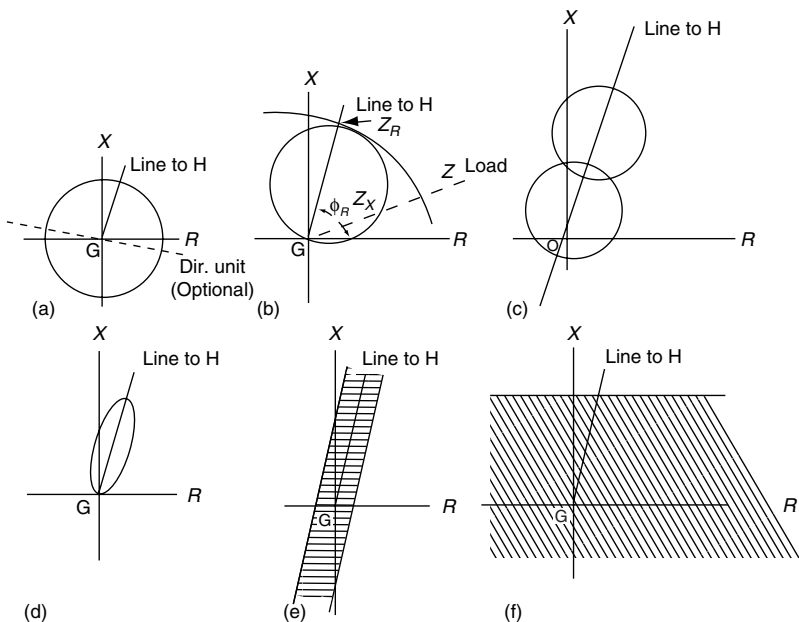

FIGURE 6.13 Distance relay characteristics on the R – X diagram: (a) impedance; (b) mho; (c) offset mhos; (d) lens; (e) simple blinders; (f) reactance.

currents lagging at about 60°–85° than to loads that are near a 0°–30° lagging current. Load impedance is given by Equation 6.2.

$$Z_{\text{load}} = \frac{V_{\text{LN}}}{I_{\text{load}}}. \quad (6.2)$$

A high current is a low impedance. Thus, for heavy loads the impedance phasor moves toward the origin; for light loads, it moves away from the origin. In other words, distance relays of Figure 6.13b through Figure 6.13e can operate on a fault current less than the load current.

Lagging load from G to H (see Figure 6.12a) is a phasor in the first quadrant as shown in Figure 6.13b. Lagging load from H to G is a phasor in the second quadrant ($-R + X$) on the R - X diagrams of Figure 6.13.

A load of 5 A secondary and 120 V line to neutral appears to the relays as

$$Z_{\text{load}} = \frac{120}{\sqrt{3}(5)} = 13.86 \Omega \text{ secondary}. \quad (6.3)$$

The equation for the mho circle through the origin is

$$Z = \frac{Z_R}{2} - \frac{Z_R}{2 \angle \phi}. \quad (6.4)$$

The $Z_R/2$ is the offset from the origin, $Z_R \angle \phi$ is the radius from the offset point. When the offset is along the X axis and ϕ is 0°, relative to the R axis, $Z=0$. When ϕ is 180°, $Z=Z_R$. When the mho circle is tilted, as in Figure 6.13b, ϕ is the angle of ϕ_R of the offset.

Various operating points on the mho circle characteristic are determined by Equation 6.5;

$$Z_X = Z_R \cos(\phi_R - \phi_X), \quad (6.5)$$

where Z_X is the impedance from the origin to any point on the circle at angle ϕ_X , and Z_R is the relay reach at ϕ_R .

For example, determine the reach of an mho unit along a 75° angle line if the maximum load into the line is 5 A secondary at 30° lagging. From Equation 6.3, the load impedance is 13.86 Ω secondary. This is Z_X in Equation 6.5 with $\phi_X = 30^\circ$. A typical angle for an mho unit is 75°. Thus,

$$13.86 = Z_R \cos(75^\circ - 30^\circ), \text{ and solving yields}$$

$$Z_R = 19.60 \Omega \text{ secondary}. \quad (6.6)$$

This can be translated into primary line ohms with the basic formula

$$Z_{R(sec)} = \frac{Z_{R(Pri)}R_c}{R_v}, \quad (6.7)$$

where R_c and R_v are the CT and VT ratios (see Chapter 5). The line reach on a 115 kV line with 600:5 CTs would be

$$Z_{R(Pri)} = \frac{Z_{R(sec)}R_v}{R_c} = \frac{19.6(1000)}{120} = 163.3 \Omega \text{ primary.} \quad (6.8)$$

On the basis of the typical 0.8 Ω /mi, the 163.3 Ω reach is about 204 m, a very long line at this voltage. Interestingly, one type of distance relay has a maximum specified reach at 20 secondary ohms, derived from Equation 6.5.

The MVA represented by the 5 A load is

$$\text{MVA} = \frac{\sqrt{3}\text{kV} \times I}{1000} = \frac{\sqrt{3}(115)(5)(120)}{1000} = 119.5 \text{ MVA.} \quad (6.9)$$

The primary protection of a line such as GH in Figure 6.12 requires two distance units. This is shown in Figure 6.14 for station G, using two mho units. Zone 1 unit operates instantaneously and is commonly set for nZ_{GH} where n is less than 1, commonly 0.9. Zone 2 unit is set with n greater than 1 or about ± 1.5 , depending on the system to the right of station H. A time-coordinating delay is required for zone 2 because it overreaches bus H.

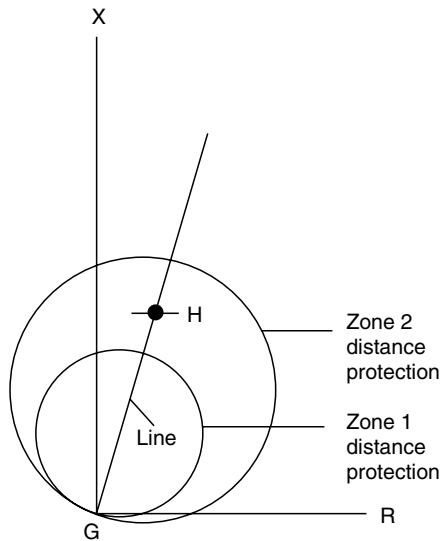

FIGURE 6.14 Distance mho units applied at G for the primary protection of line GH of Figure 6.12.

A third zone, zone 3, is used in the hope of providing remote backup protection for the line(s) to the right on station H. This is often difficult, as explained in Chapter 12. Sometimes zone 3 at G is set to look backward from, or to the left of, station G. This can be used for backup or as a carrier-start unit in pilot relaying, as covered in Chapter 13. In these applications, the zone 3 mho-type unit, with offset to include the origin, should be used. This characteristic is the lower mho unit in Figure 6.13c. This assures operation for close-in faults, for which the voltages are very low or zero. The mho relays can be either single-phase or polyphase types.

6.5.8 SINGLE-PHASE MHO UNITS

For the single-phase types, three mho units (circles through the origin as in Figure 6.13b) are required for a protective zone. All three units operate for three-phase faults, but for phase-to-phase and double phase-to-ground faults, only one unit operates. Thus,

- The A unit energized by I_{ab} and V_{ab} operates for ab - gnd faults.
- The B unit energized by I_{bc} and V_{bc} operates for bc - gnd faults.
- The C unit energized by I_{ca} and V_{ca} operates for ca - gnd faults.

The B and C units will not operate for the ab faults, the A and C units will not operate for the bc faults, and the A and B units will not operate for the ca faults.

This can be seen for the bc faults from Figure 4.29d and Figure 4.29e. The fault current I_{bc} is large and the fault voltage V_{bc} is small to provide a low impedance for operation. However, for the bc faults I_{ab} and I_{ca} are small, whereas V_{ab} and V_{ca} are large for a large apparent impedance. These impedances will be outside the operating circles for the A and C units. Similar conditions apply for the ab and ca faults.

The single-phase mho unit is shown in Figure 6.15. An air-gap transformer, known as a transactor or compensator, provides a secondary voltage $I_{ab}Z_c$ for the A unit, leading the primary current to less than 90° . The diameter

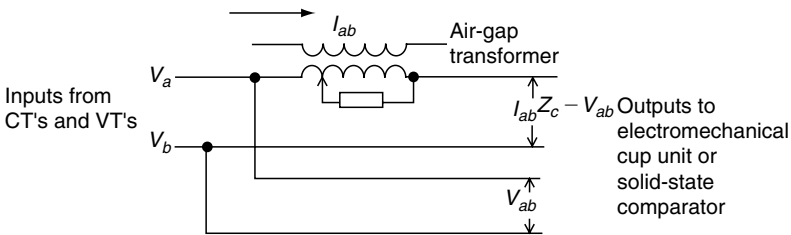

FIGURE 6.15 Single-phase MHO unit (shown for the A unit).

of the mho circle is determined by the mutual reactance of the transactor modified by the resistor. The combined output voltage is $I_{ab}Z_c - V_{ab}$. This voltage with a polarizing voltage V_{ab} is compared to provide the mho circle through the origin as in Figure 6.13b and Equation 6.4.

For example, for electromechanical relays the induction cup unit in Figure 6.10 is used where the A unit, $I_{ab}Z_c$ (see Figure 6.15) is on the left horizontal pole (operating coil), V_{ab} on the right horizontal pole (restraining coil), and V_{ab} across the two vertical poles (polarizing coils).

For solid-state relays the two voltages are compared with a static-type phase-angle comparator (or the equivalent) digitized in microprocessor relays. The units may be packaged separately or in various combinations, depending on the manufacturer and application.

6.5.9 POLYPHASE MHO UNITS

The polyphase type has two units for a zone protection as shown in Figure 6.13b: (1) a mho circle through the origin, operating for three-phase faults; and (2) a phase-to-phase unit, with a large operating circle partly shown as an arc. This unit operates neither on balanced conditions (load, swings, and such) nor for faults behind the relay (third and fourth quadrants).

Where distance relays are set to operate through wye–delta transformers the reach of the single-phase units for phase-to-phase faults is complex because a phase-to-phase fault on one side of the bank appears more or less like a phase-to-ground fault on the other side. This is shown in Figure 9.20.

Polyphase relays can be set through a wye–delta bank to operate for faults on the other side, using a setting that includes the X value of the transformer.

6.5.9.1 Three-Phase Fault Units

The polyphase three-phase unit is shown in Figure 6.16. Only one compensator is necessary to receive the phase a current. Thus, the output voltages are

$$V_x = V_{an} - 1.5(I_a - 3I_0)Z_c, \quad (6.10)$$

$$V_y = V_{bn}, \quad (6.11)$$

$$V_z = V_{cn}. \quad (6.12)$$

The cylinder unit (see Figure 6.10) is like a two-phase motor operating when negative sequence xzy is applied and restrains on positive sequence xyz or operates when V_{zy} lags V_{xy} and restrains when V_{zy} leads V_{xy} . A fault at the balance point (Z_c) results in xyz in line as shown, a no-area–triangle and no operation. This is the decision point.

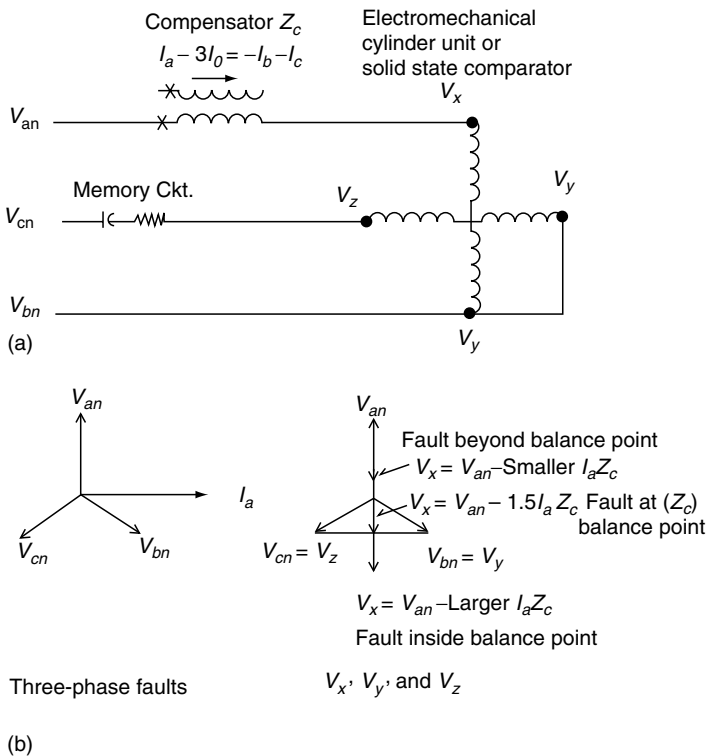

FIGURE 6.16 The polyphase distance relay—three-phase unit: (a) three-phase-fault unit; (b) phasors for a three-phase fault (I_a only shown lagging 90°).

A fault on the line up to the balance point produces an xzy triangle and operation. A fault beyond the balance point produces an xyz triangle and no operation. For a fault behind the relay, the current reverses and a large xyz triangle results, again no operation. The memory circuit momentarily delays the collapse of V_y and Z_z for close-in faults that may reduce the phase b and c voltage to very low values, or zero.

In the compensator, $3I_0$ helps the unit to operate on double-phase-to-ground faults when z_0 of the system is very low. From Figure 4.15, it can be seen that as z_0 approaches zero, the double-phase-to-ground faults begin to look like three-phase faults. When the solid-state comparator is used $V_{xy} = V_{ab} - (I_a - I_b)Z_c$ and $V_{zy} = -jk V_{ab}$ are compared.

6.5.9.2 Phase-to-Phase Fault Units

The polyphase phase-to-phase unit is shown in Figure 6.17 with two compensators. The equations are

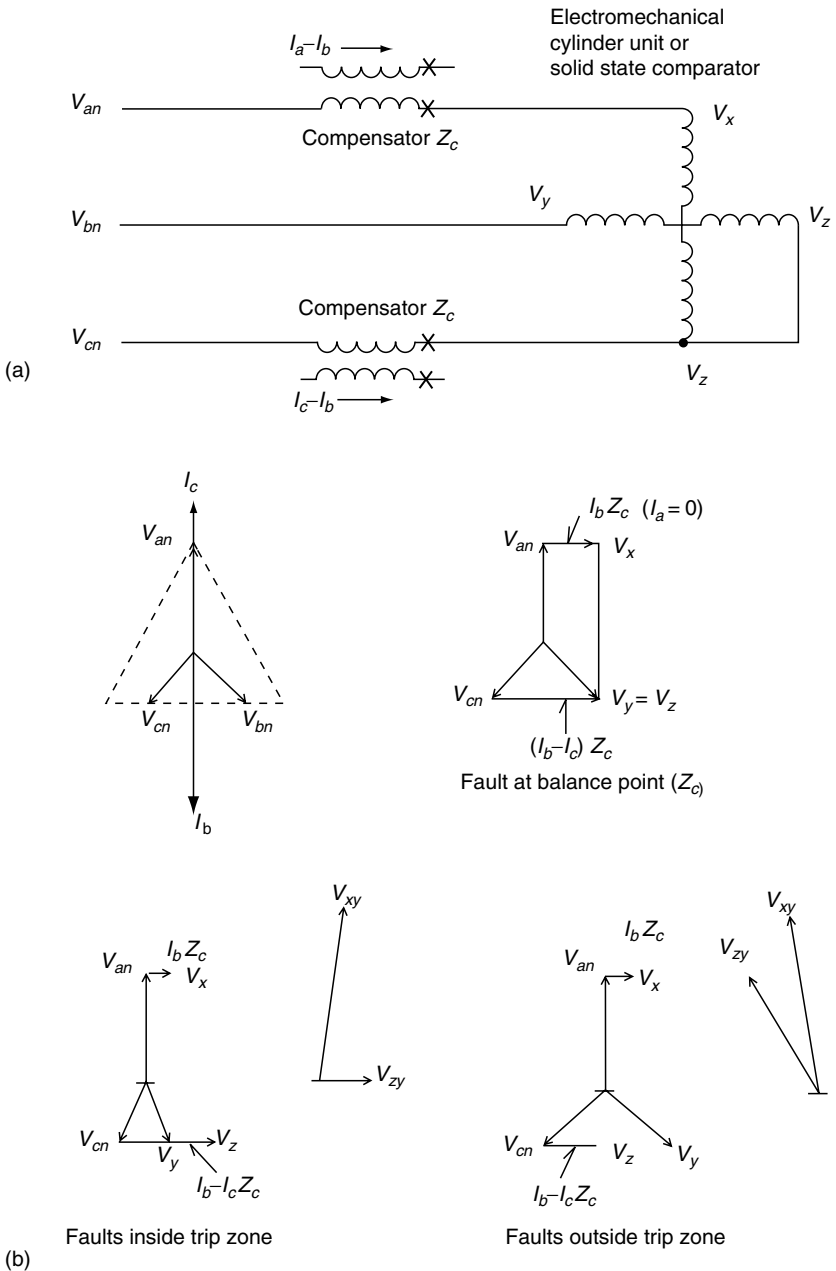

FIGURE 6.17 The polyphase distance relay: phase-to-phase unit: (a) the phase-to-phase fault unit; (b) phasors for a bc fault (currents shown at 90°).

$$V_x = V_{an} - (I_a - I_b)Z_c, \quad (6.13)$$

$$V_y = V_{bn}, \quad (6.14)$$

$$V_z = V_{cn} - (I_c - I_b)Z_c. \quad (6.15)$$

With reference to [Figure 6.17](#), phase-to-phase faults at the balance or decision point $V_xV_yV_z$ provide a zero-area triangle for the electromechanical cylinder unit, or V_{zy} and V_{xy} in phase for the solid-state comparator, with no operation. Any fault inside the trip-zone—negative sequence xyz , or when V_{zy} lags V_{xy} , causes operation. Any fault beyond or outside the trip-zone positive sequence xyz , or if V_{zy} leads V_{xy} results in no operation.

The phase-to-phase unit is a variable circle fixed at the balance point setting of Z_c or Z_R in [Figure 6.13b](#). The equation of this circle is

$$\text{Offset } Z = \frac{1}{2}(Z_c - Z_s), \quad (6.16)$$

$$\text{Radius } Z = \frac{1}{2}(Z_c + Z_s)\angle\phi, \quad (6.17)$$

where $Z_c(Z_R)$ is the set reach and Z_s is the source impedance behind the unit. Although the circle extends into the third and fourth quadrants, this has no practical meaning because the fault current reverses for faults behind the unit. This reversal always provides xyz and V_{zy} leading V_{xy} , and no operation. Since the unit does not operate on positive sequence quantities (xyz), it will not operate on balanced conditions, such as load and swings. This unit will operate for line-to-ground faults within approximately 30% of the Z_c setting. This is not a fixed reach.

6.5.10 OTHER MHO UNITS

The mho unit can be offset, as illustrated in [Figure 6.13c](#) or changed to other shapes, such as a lens, (see [Figure 6.13](#)), tomato, rectangular, and so on. Each has its perceived advantages that are useful in various applications.

The characteristics of [Figure 6.13](#), but with the lower circle through the origin, and [Figure 6.13d](#) and [Figure 6.13e](#) are applicable to long, heavily loaded lines. [Figure 6.13d](#) is called a lens unit and [Figure 6.13e](#) a single-blinder unit. These provide protection for faults along the line, but do not operate on heavy loads for which the load impedance would otherwise fall within the unit-operating circle.

Two reactance units (see next section and [Figure 6.13f](#)) with their characteristics shifted, as shown in [Figure 6.13e](#), provide a restricted-operating zone along the protected line. The right unit operates for a large area to the left, the left unit for a large area to the right: outputs in series operation are indicated by the cross-hatched area. This type of characteristic is generally

used for out-of-step detection and tripping, as described in [Chapter 14](#). If used for fault protection mho fault detectors must be used.

As indicated in [Section 6.5.7](#), the mho unit of [Figure 6.13c](#) that includes the origin provides continued operation beyond any memory action for zero or near-zero-volt faults. An example is a bolted three-phase fault at or near the voltage transformer connection.

6.5.11 REACTANCE UNITS

Reactance units can be obtained from the design of [Figure 6.15](#), with the air-gap transformer output of X instead of Z . The characteristic is a straight line at the set point (Z_R or Z_C) parallel to the R axis, as in [Figure 6.13f](#). It is not directional, but will operate for faults behind the relay. Thus, this unit is very “trigger happy” so the operation must be restricted by an mho-type fault detector both for faults behind the relay and for load and swings.

The reactance unit appears to have increased fault arc protection because arcs are resistive. This is true only for radial circuits in which fault current is supplied from only one terminal. When fault current is supplied from both the terminals and the line is carrying load, the fault sources are not in phase. This results in the reactance units “viewing” the arc as an enlarged $R + jX$ value. Thus, at one terminal the unit may not operate on arc faults, for they can appear outside the operating area and may cause reactance unit on the next section to operate incorrectly. This apparent impedance effect is discussed further in [Chapter 12](#).

6.6 GROUND DISTANCE RELAYS

In [Chapter 4](#), it was shown that the positive sequence voltage drop during faults is maximum at the source and minimum or zero at the fault. Thus, the ratio of the voltage and current as in [Equation 6.1](#) indicated the distance to the fault. Unfortunately, for ground faults, the zero-sequence voltage drop is maximum at the fault and minimum or zero at the neutral or wye-ground–delta power transformers. Thus, the ratio of the voltage and current

$$Z_{R0} = \frac{3I_0(nZ_0)}{3I_0} = nZ_0 \quad (6.18)$$

indicates distance behind the relay to the ground source, hence they cannot be used for ground distance relaying. Several methods have been used to resolve this; (1) voltage compensation or (2) current compensation.

Consider a phase- a -to-ground fault on a line with Z_{1L} and Z_{0L} as the positive and zero sequence line impedances and n the location of the fault from the relay. The fault currents through the relay are I_1 , I_2 , and I_0 . Then for a fault at nZ_{1L} with a single-phase unit.

$$\frac{V_{ag}}{I_a} = nZ_{1L}(I_1 + I_2) + \frac{nZ_{0L}I_0}{I_1 + I_2 + I_0}. \quad (6.19)$$

For (1) voltage compensation, subtract out $nZ_{1L}(I_1 + I_2)$ and use I_0 . Then from Equation 6.19, for the phase a -to-ground unit

$$Z_R = \frac{V_{ag} - nZ_{1L}(I_1 + I_2)}{I_0} = \frac{nZ_{0L}I_0}{I_0} = nZ_{0L}. \quad (6.20)$$

Additional units required for b -to-ground using V_{bg} for the c -to-ground faults using V_{cg} .

For (2) current compensation, let $nZ_{0L} = pnZ_{1L}$ where $p = Z_{0L}/Z_{1L}$. Then from Equation 6.19

$$Z_R = \frac{V_{ag}}{I_a} = \frac{nZ_{1L}(I_1 + I_2 + pI_0)}{I_1 + I_2 + I_0}. \quad (6.21)$$

If the current input is changed to $I_1 + I_2 + pI_0 = I_a + (p - 1)I_0$, then

$$Z_R = \frac{V_{ag}}{I_a + mI_0} = nZ_{1L}, \quad (6.22)$$

where $m = Z_{0L} - Z_{1L}/Z_{1L}$. Again additional units are required for b -ground and c -ground faults except for the polyphase unit.

Considering arc resistance and mutual coupling from an adjacent parallel line, the complete formula for current compensated single-phase ground distance relay is;

$$Z_R = \frac{V_{ag}}{I_{\text{relay}}} = nZ_{1L} + R_{\text{arc}} \left(\frac{3I_0}{I_{\text{relay}}} \right), \quad (6.23)$$

where

$$I_{\text{relay}} = \frac{I_a + I_0(Z_{0L} + Z_{1L})}{Z_{1L} + I_{0E}Z_{0M}/Z_{1L}}. \quad (6.24)$$

I_{0E} is the zero sequence current in the parallel line and Z_{0M} the mutual coupling impedance between the two lines.

Another type operates on the principle that, at the fault $V_{0F} + V_{1F} + V_{2F} = 0$. This relation is reproduced by compensators at the relay location. The modified V_0 is used as an operating quantity, and the modified $V_1 + V_2$ as restraint. For single-phase-to-ground faults within the preset reach, V_0 operating is greater than the $V_1 + V_2$ restraint to trip. Faults outside the preset zone provide restraint greater than the operating quantity.

6.7 SOLID-STATE MICROPROCESSOR RELAYS

Solid-state units provide greater flexibility, more adjustable characteristics, increased range of settings, high accuracy, reduced size, and lower costs, along with many ancillary functions, such as control logic, event recording, fault location data, remote setting, self-monitoring and checking, and others. In solid-state relays the analog power system quantities from current and voltage transformers or devices are passed through transformers to provide electrical isolation and low-level secondary voltages.

The protection function outlined earlier is available using microprocessor technology. The details of accomplishing this seem relatively unimportant to the protection principles; thus, they are beyond the scope of our discussion here. However, typical logic units that may be involved in a microprocessor relay are shown in Figure 6.18.

In very general terms, these are (1) input transformers that reduce the power system current and voltage quantities to low voltages and provide first-level filtering; (2) low-pass filter that removes high-frequency noise;

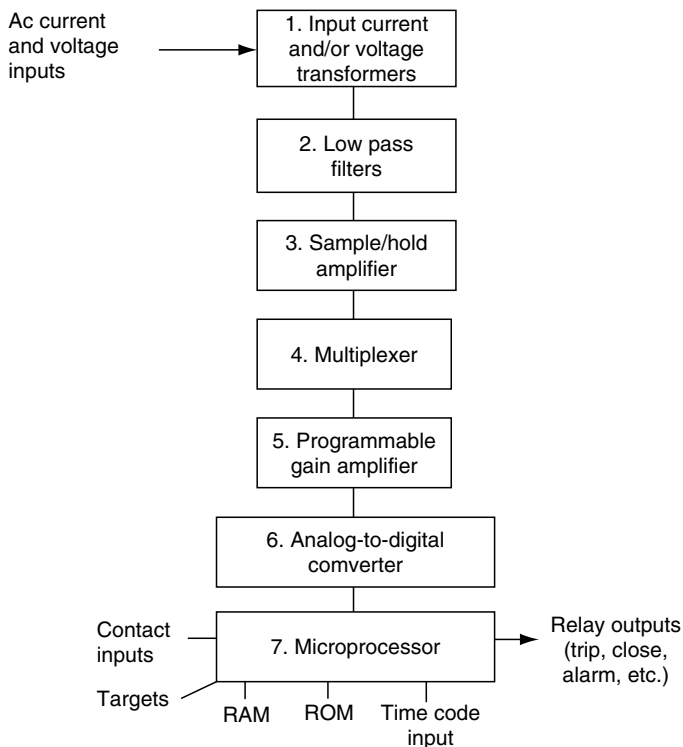

FIGURE 6.18 Typical logic units in a microprocessor relay.

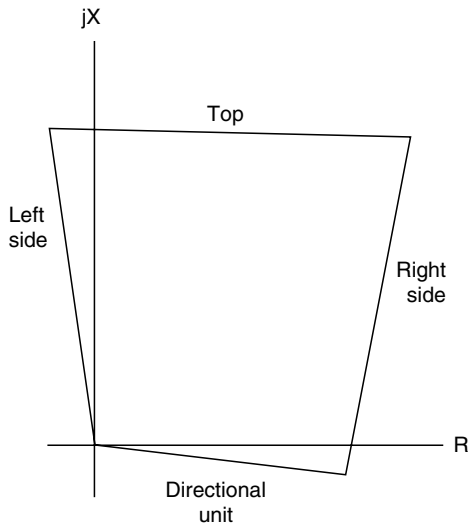

FIGURE 6.19 Quadrilateral distance characteristics.

(3) sample-hold amplifier that samples and holds the analog signals at time intervals determined by the sampling clock to preserve the phase information; (4) multiplexer that selects one sample-hold signal at a time for subsequent scaling and conversion to digital; (5) programmable gain amplifier for current signals that have a wide dynamic range (for voltage signals, the gain is 1); (6) Analog-to-digital converter that converts the analog signals to digital; (7) microprocessors with appropriate software that provides the required protection characteristics that are amplified to operate auxiliary units for tripping, closing, alarms, and so on.

The capability and flexibility inherent in microprocessor relays have increased the availability and utilization of distance elements with quadrilateral characteristics. Such characteristics are illustrated in Figure 6.19. The quadrilateral characteristic basically involves the combination of four measuring units. These units consist of a reactance unit (top line), two resistive units (left and right sides), and a directional element (bottom line). While such characteristics were available in some electromechanical designs, these designs were very complicated and operating times of the units were often less than desirable. The extensive computational power that exists in modern microprocessor relays greatly facilitates the task of creating a quadrilateral characteristic. From an application standpoint, the operating area of a distance element with a quadrilateral type characteristic is ideal. With this type of characteristic, the tripping area can be arranged closely to enclose the desired tripping area as shown in Figure 6.20. This is especially useful for ground faults that are often restricted and, therefore, the ability to detect significant

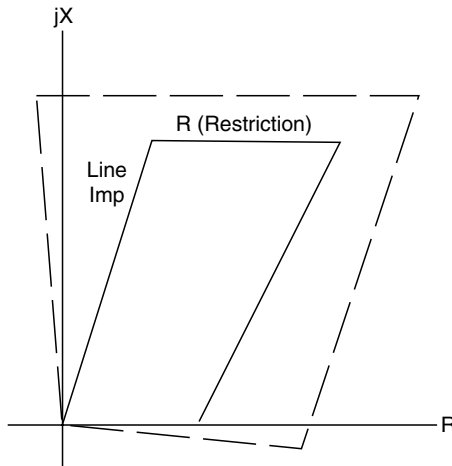

FIGURE 6.20 Quadrilateral distance element set to enclose desired area in which fault restriction may exist.

resistance associated with the restriction is important. For these reasons, quadrilateral distance elements are often applied in association with ground distance elements. With the ability to closely enclose the desired trip area results in a more secure application.

6.8 SUMMARY

This chapter has presented the fundamentals of system protection and very briefly outlined various basic designs in wide use in these systems throughout the United States. The aim is to provide a background for the later chapters on the protection aspects of the various power system components.

BIBLIOGRAPHY

- Lewis, W.A. and Tippett, L.S., Fundamental basis for distance relaying on a three phase system. *AIEE Trans.*, 66, 1947, pp. 694–708. The original was presented, but not published, at an AIEE meeting in 1932.
- Sonnemann, W.K., A study of directional elements for phase relays. *AIEE Trans.*, 69, II, 1950, pp. 1438–1451.
- Van, C. and Warrington, A.C., Application of OHM and MHO principle to protective relaying. *AIEE Trans.*, 65, 1946, pp. 378–386, 490.

7 System-Grounding Principles

7.1 INTRODUCTION

Power system grounding is very important, particularly because the large majority of faults involve grounding. Thus, it has a significant effect on the protection of all the components of the power system. The principal purposes of grounding are to minimize potential transient overvoltages to comply with local, state, and national codes for personnel safety requirements; and to assist in the rapid detection and isolation of the trouble or fault areas.

A basic review of system grounding is in order, together with its fundamental technology and a general evaluation of the methods. There are four types: (1) ungrounded, (2) high impedance, (3) low impedance, and (4) effective or solid grounding. Each has its application in practice, together with advantages and disadvantages. The recommendations are based on general practices and some personal preferences. It should be recognized that there are many factors in each specific system or application that can well justify variations or a different approach. Just as relaying is highly influenced by personality, to a degree, so is system grounding.

7.2 UNGROUNDED SYSTEMS

Ungrounded systems are power systems with no intentionally applied grounding. However, they are grounded by the natural capacitance of the system to ground. Thus, the fault current level is very low, such that equipment damage is minimal; and it is not necessarily essential that the faulted area be rapidly isolated. This is an advantage; therefore, it is sometimes used in industrial plant systems where a high continuity of service is important to minimize interruptions of expensive production processes. However, ungrounded systems are subject to high and destructive transient overvoltages and, consequently, are always potential hazards to equipment and personnel. Thus, they are generally not recommended, even though they are normally used.

Phase-to-ground faults on an ungrounded system essentially shift the normal balanced voltage triangle, as shown in [Figure 7.1](#). The small currents flowing through the series phase impedances will cause a very slight distortion of the voltage triangle, but practically, it is as shown in [Figure 7.1b](#).

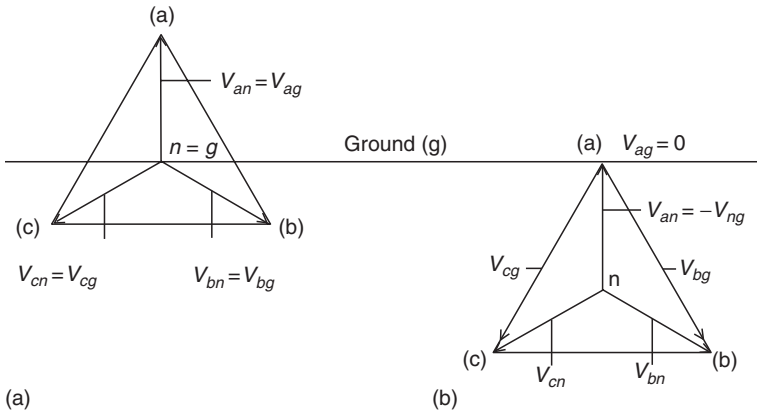

FIGURE 7.1 Voltage shift for a phase-*a*-to ground fault on an ungrounded system: (a) normal balanced system; (b) phase *a* solidly grounded.

A typical circuit is illustrated in Figure 7.2 showing the current flow. The sequence networks are shown in Figure 7.3. The distributed capacitive reactance values X_{1C} , X_{2C} , and X_{0C} are very large, whereas the series reactance (or impedance) values X_{1S} , X_T , X_{1L} , X_{0L} , and so on, are relatively very small. Thus, practically, X_{1C} is shorted out by X_{1S} and X_T in the positive-sequence network, and similarly for the negative-sequence network. Because these series impedances are very low, X_1 and X_2 approach zero, in relation to the large value of X_{0C} . Therefore,

$$I_1 = I_2 = I_0 = \frac{V_S}{X_{0C}} \quad (7.1)$$

and

$$I_a = 3I_0 = \frac{3V_S}{X_{0C}}. \quad (7.2)$$

This calculation can be made in per unit (pu) or amperes (A), remembering that V_S and all the reactances (impedances) are line-to-neutral quantities.

The unfaulted phase *b* and *c* currents will be zero when determined from the sequence currents of Equation 7.1. This is correct for the fault itself. However, throughout the system the distributed capacitance X_{1C} and X_{2C} is actually paralleled with the series reactances X_{1S} , X_T , and so on, so that in the system I_1 and I_2 are not quite equal to I_0 . Thus, I_b and I_c exist and are small, but they are necessary as the return paths for I_a fault current. This is shown in Figure 7.2. If $I_a = -1$ pu, then $I_b = 0.577 \angle +30^\circ$ and $I_c = 0.577 \angle -30^\circ$ pu.

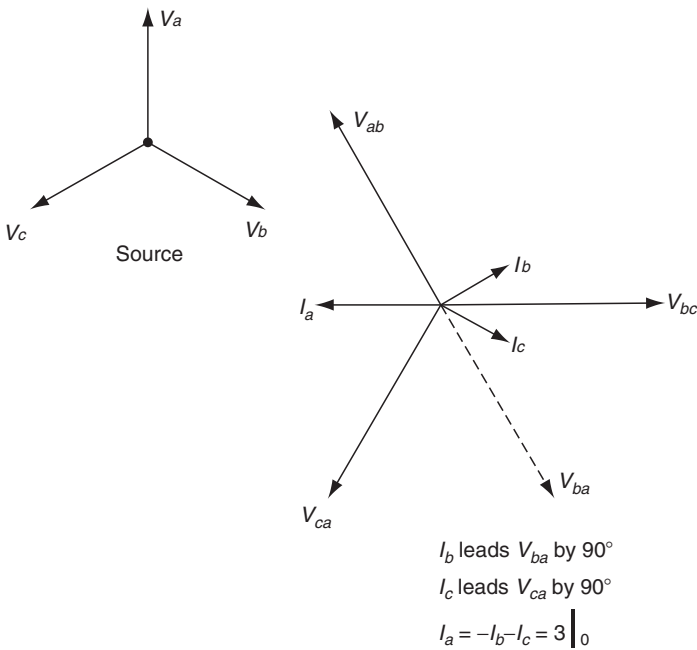
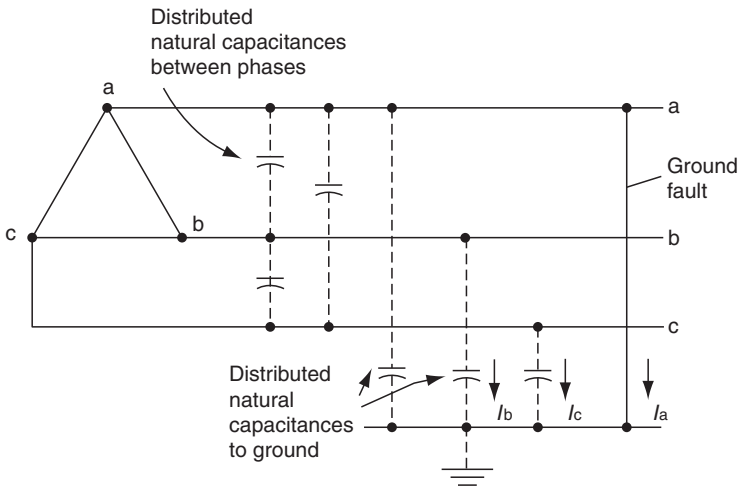
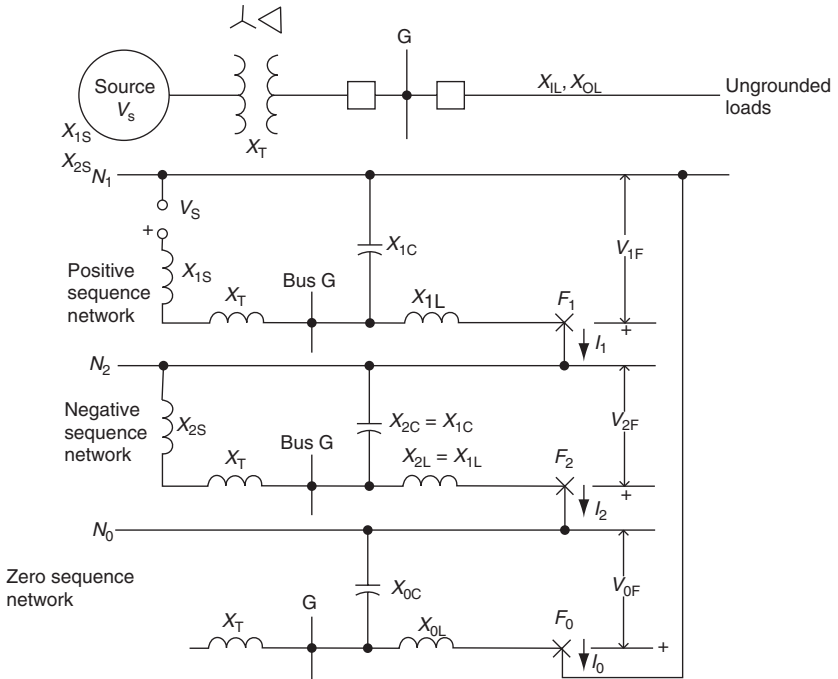

FIGURE 7.2 Phase-to-ground fault on an ungrounded system.

In industrial applications where ungrounded systems might be used, the X_{0C} is equal practically to $X_{1C} = X_{2C}$ and is equivalent to the charging capacitance of the transformers, cables, motors, surge-suppression capacitors, local generators, and so on, in the ungrounded circuit area. Various reference



X_{1C} , X_{2C} , X_{0C} are lumped equivalents of the distributed capacitance between phases to network and to ground.

FIGURE 7.3 Sequence networks and interconnections for a phase-*a*-to-ground fault on an ungrounded system.

sources provide tables and curves for typical charging capacitances per phase of the power system components. In an existing system the total capacitance can be determined by dividing the measured phase-charging current into the line-to-neutral voltage.

Note that as faults occur in different parts of the ungrounded system, X_{0C} does not change significantly. Because the series impedances are quite small in comparison, the fault currents are the same practically and independent of the fault location. This makes it impractical for selective location of faults on these systems by the protective relays.

When a phase-to-ground fault positively occurs, the unfaulted phase-to-ground voltages are increased particularly by $\sqrt{3}$ (see Figure 7.1b). Thus, these systems require line-to-line voltage insulation.

In the normal-balanced system (see Figure 7.1a) $V_{an} = V_{ag}$, $V_{bn} = V_{bg}$, and $V_{cn} = V_{cg}$. When a ground fault occurs, the phase-to-neutral voltages and the phase-to-ground voltages are quite different. The neutral *n* or *N* is defined as “the point that has the same potential as the point of junction of a group (three

for three-phase systems) of equal nonreactive resistances if connected at their free ends to the appropriate main terminals (phases of the power system)” (IEEE 100). This is the n shown in [Figure 7.1b](#).

From this figure, the voltage drop around the right-hand triangle is

$$V_{bg} - V_{bn} - V_{ng} = 0 \quad (7.3)$$

and around the left triangle,

$$V_{cg} - V_{cn} - V_{ng} = 0. \quad (7.4)$$

In addition,

$$V_{ng} + V_{an} = 0. \quad (7.5)$$

From the basic equations,

$$V_{ag} + V_{bg} + V_{cg} = 3V_0, \quad (7.6)$$

$$V_{an} + V_{bn} + V_{cn} = 0. \quad (7.7)$$

Subtracting Equation 7.7 from Equation 7.6, substituting Equation 7.3 through Equation 7.5, and with $V_{ag} = 0$:

$$\begin{aligned} V_{ag} - V_{an} + V_{bg} - V_{bn} + V_{cg} - V_{cn} &= 3V_0, \\ V_{ng} + V_{ng} + V_{ng} &= 3V_0, \\ V_{ng} &= V_0. \end{aligned} \quad (7.8)$$

Thus the neutral shift is zero-sequence voltage. In the balanced system of [Figure 7.1a](#), $n = g$, V_0 is zero, and there is no neutral shift.

7.3 TRANSIENT OVERVOLTAGES

Restriking arcs after current interruption in the breaker or in the fault can result in large destructive overvoltages in ungrounded systems. This phenomenon is illustrated in [Figure 7.4](#). In the capacitive system the current leads the voltage by nearly 90° . When the current is interrupted or the arc extinguished at or near its zero value, the voltage will be at or near its maximum value. With the breaker open, this voltage remains on the capacitor to decay at a time constant of the capacitive system. In the source system, it continues as shown for V_S . Thus, in a half cycle, the voltage across the open contact is almost twice the normal peak value. If a restrike occurs (switch closed in [Figure 7.4](#)), the basic $+1$ pu voltage of the capacitive system will shift to the system

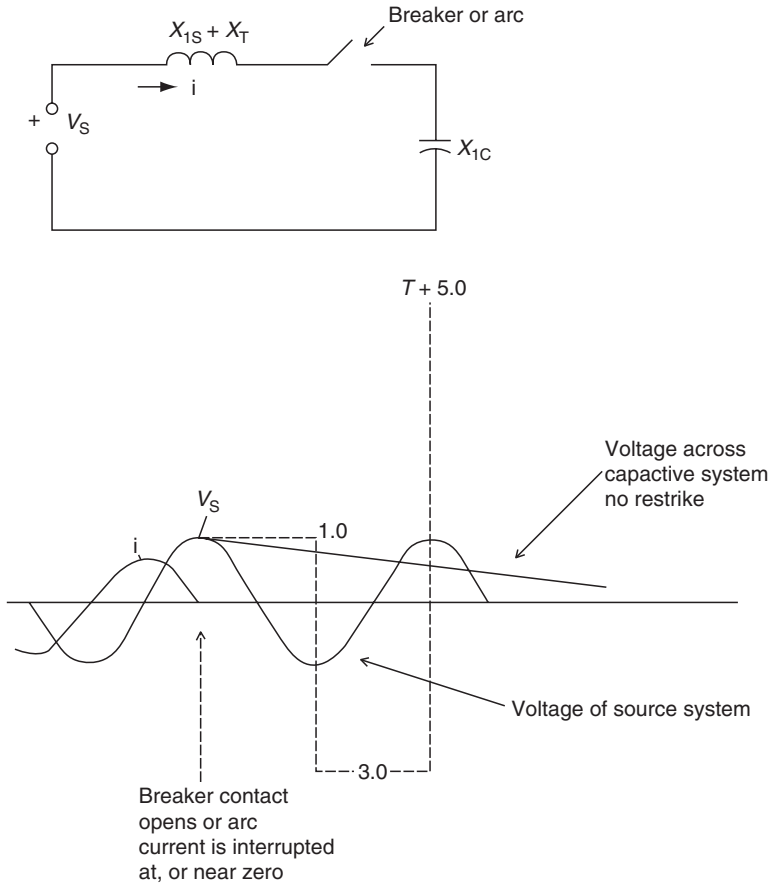

FIGURE 7.4 Transient overvoltage on an ungrounded system.

voltage of -1 pu, but because of the system inductance and inertia, it will overshoot to a maximum possibility of -3 pu. If the arc goes out again near current zero (switch open) but restrikes (switch closed) again, the system voltage will try to shift to $+1$ pu, but yet another time overshoot, this time to a potential maximum of $+5$ pu. This could continue to -7 pu, but, meanwhile, the system insulation would no doubt break down, causing a major fault. Thus, ungrounded systems should be used with caution, and applied at the lower voltages (<13.8 kV), where the system insulation levels are higher.

If this system is used, prompt attention is important to locate and correct the ground fault. As the fault current is very low, it is easy to ignore the fault and continue operation. However, with the fault the other phases are operating at basically 1.73 times the normal line-to-ground voltage. If an insulation

deterioration caused the first ground fault, the higher voltages might accelerate the breakdown of the unfaulted phases, to result in a double line-to-ground or three-phase fault. Then, high fault currents would result, requiring fast shutdown and instant loss of production.

In actual practice totally ungrounded systems do not exist. As soon as a fault detector is applied using one or three voltage transformers, the system is grounded through the high impedance of these devices. The resistance of the relays and associated ballast resistors help in limiting the transient over-voltages, so that very few cases of overvoltage essentially exist.

7.4 GROUNDED-DETECTION METHODS FOR UNGROUNDED SYSTEMS

Voltage provides the best indication of a ground fault because the current is very low and, basically, does not change with the fault location. The two methods used are shown in [Figure 7.5](#) and [Figure 7.6](#). These indicate that a ground fault exists but not where it is in the primary system.

7.4.1 THREE-VOLTAGE TRANSFORMERS

Wye-grounded–broken-delta voltage transformer connections are preferred (see [Figure 7.5](#)). Ballast resistors are used to reduce the shift of the neutral from either unbalanced excitation paths of the voltage transformers or from ferroresonance between the inductive reactance of the voltage transformers and relays and the capacitive system.

The voltage for the relay in [Figure 7.5](#) from [Figure 7.1b](#) is

$$\begin{aligned} V_{pq} &= 3V_0 = V_{ag} + V_{bg} + V_{cg} \\ &= \left(\sqrt{3}V_{LN} \cos 30^\circ \right) \times 2 = 3V_{LN}. \end{aligned} \quad (7.9)$$

Thus, the voltage available to the relay for a phase-to-ground fault on the ungrounded system is three times the line-to-neutral normal voltage. Usually, the VT ratio of primary V_{LN} : 69.3 V is used so that the maximum solid ground relay voltage would be $3 \times 69.3 = 208$ V. Because the relay will be used to send alarm, its continuous voltage rating should be greater than, or equal to this value. Otherwise, an auxiliary stepdown voltage transformer must be used.

[Figure 7.5](#) is simplified. Usually, the voltage transformer will be wye-grounded–wye-grounded and an auxiliary wye-grounded–broken-delta transformer will be used. Sometimes the main voltage transformer will have a double secondary, one of which can be connected to the broken delta. Lamps can be connected across each broken-delta secondary winding to provide visual indications. Typical resistance values across the secondary winding, derived from experience, are shown in [Table 7.1](#).

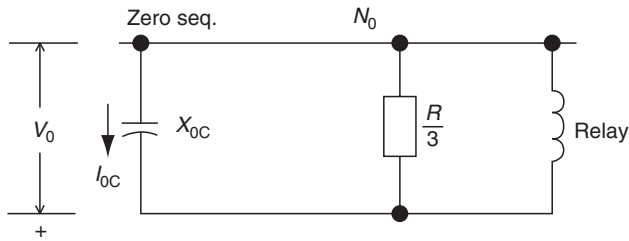
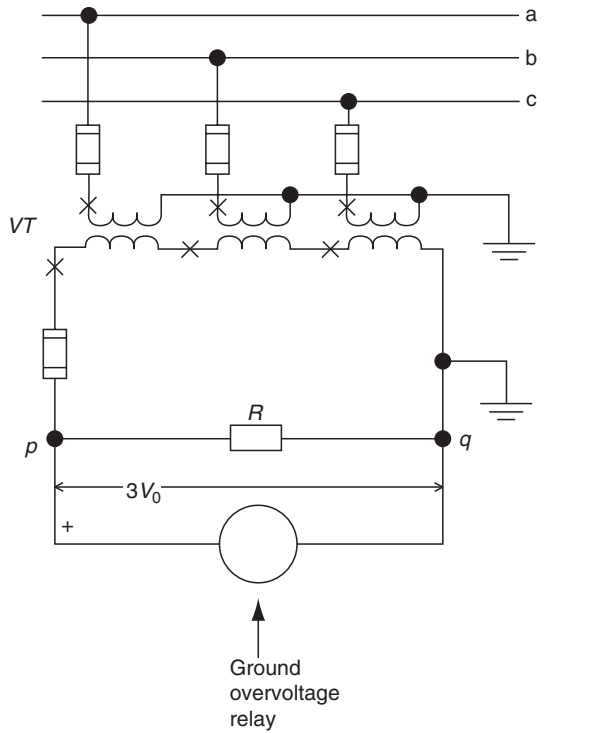

Neglects negligible system & VT reactances

FIGURE 7.5 Voltage ground-fault detection using three voltage transformers connected wye-grounded–broken-delta.

7.4.2 SINGLE-VOLTAGE TRANSFORMERS

The single-voltage transformer of [Figure 7.6](#) is especially subject to possible ferroresonance, without adequate resistance in the secondary. Without this resistance,

$$V_{bg} = \frac{\sqrt{3}V_{LL}}{3 - (X_C/X_E)}. \quad (7.10)$$

TABLE 7.1
Typical Resistance Values Across Secondary
Winding

		Resistor <i>R</i>	
		Ohms	Watts at 208 V
2.4	2,400:120	250	175
4.16	4,200:120	125	350
7.2	7,200:120	85	510
13.8	14,400:120	85	510

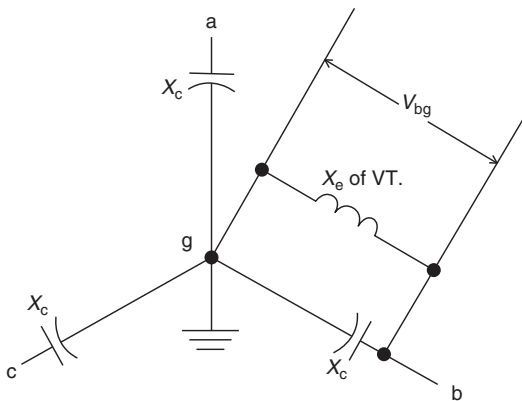
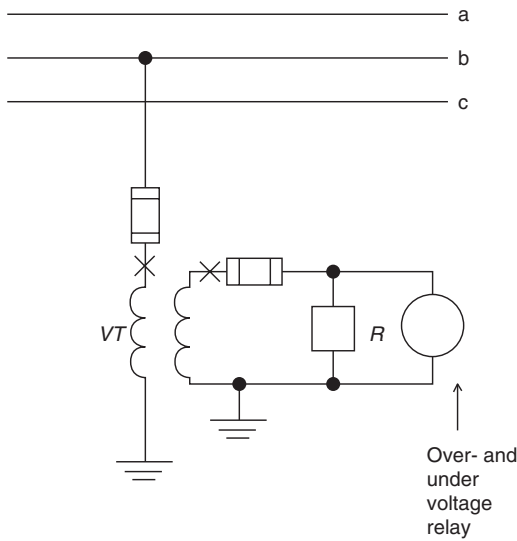

FIGURE 7.6 Voltage ground detection using single-voltage transformer.

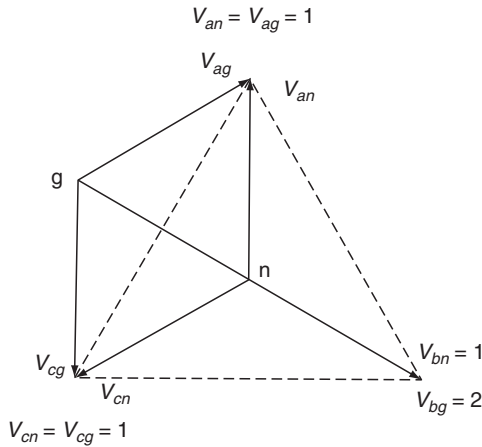

FIGURE 7.7 Phasor diagram illustrating neutral inversion with unloaded voltage transformer connected to phase *b* as shown in Figure 7.6. Example with $X_c = -j3$ and $X_e = j2$. All values in per unit.

If the distributed system capacitance X_C divided by the transformer exciting reactance X_e equals 3, then theoretically, V_{bg} is infinite. Saturation of the voltage transformer would prevent this, but it is quite possible for the voltage triangle *abc* to have its ground point well outside this triangle. This is called “neutral inversion,” as illustrated in Figure 7.7. In this case, the ratio of X_C/X_e is 1.5, therefore, in Equation 7.10, $V_{bg} = 2.0$ pu as shown in Figure 7.7. For simplicity, resistance neither in the system nor across the voltage transformer secondary is assumed. Sustained phase-to-ground voltages almost four times higher have been experienced. Also, the interaction of the variable transformer-exciting impedance with system capacitance can produce ferroresonance, with very high and distorted waveforms. This application of the single VT is not recommended, but if used the secondary system should be loaded with resistance.

This ground detection scheme must be used with caution to avoid “neutral” inversion and ferroresonance, as outlined in the earlier paragraph. The voltage relay is set to have its contacts held open for the normal line-to-ground secondary voltage. When a ground fault occurs on phase *b*, the voltage collapses and the voltage relay resets to close the undervoltage contacts. If a phase *a* or *c* ground fault occurs, the relay voltage increases by about 1.73 V to cause the relay to operate on overvoltage. Either under- or overvoltage operation usually sets off an alarm to alert the operators of a ground fault so that they can arrange an orderly or convenient shutdown.

7.5 HIGH-IMPEDANCE-GROUNDING SYSTEMS

There are two types of high-impedance-grounding system: resonant grounding and high-resistance grounding. The first has very limited use in the United

States, although it is used elsewhere. The major American use is for generator grounding in the New England area. High-resistance grounding is widely used for generators and in industrial plants. These applications are reviewed later.

7.5.1 RESONANT GROUNDING

These systems are also known as ground-fault neutralizer or “Petersen coil” systems. The total system capacitance to ground is canceled by an equal inductance connected in the neutral (Figure 7.8). If the neutral reactor is is

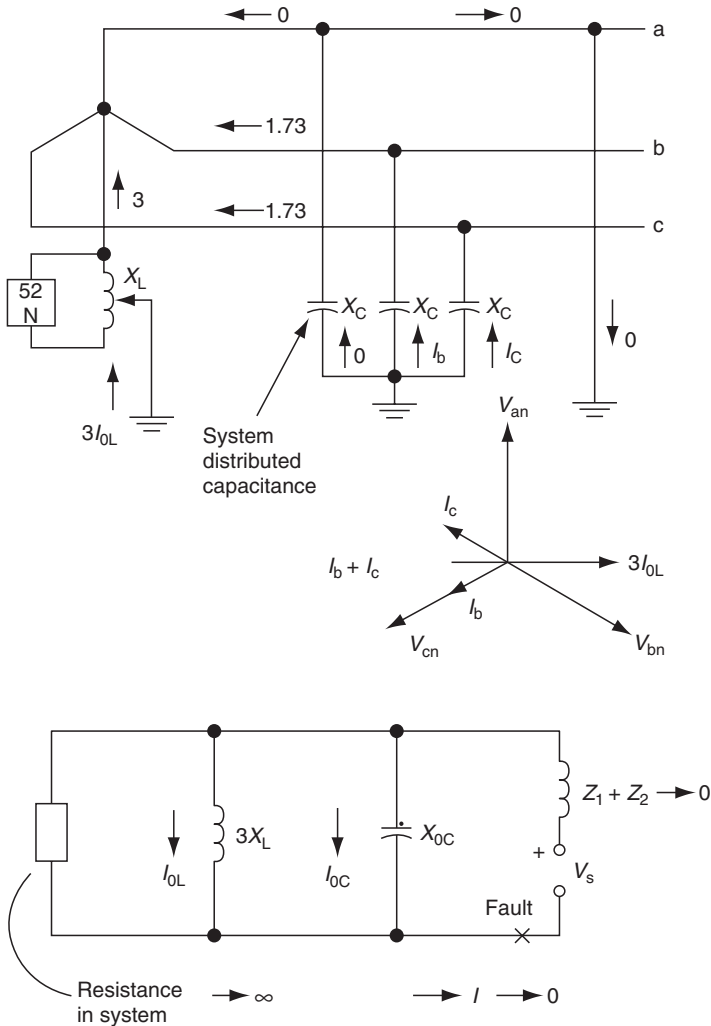

FIGURE 7.8 Resonant grounding.

tuned exactly to the total system capacitance, the current in the fault is zero. In fact, in practice, taps on the reactor permit close tuning, so that the fault current is very small and the fault arc will not maintain itself. The circuit is a parallel resonance circuit, and the very low fault currents cause minimum fault damage. As the fault arc is extinguished, the reactor capacitance continues to produce essentially a voltage, equal to the system line-to-neutral voltage; accordingly, the voltage across the arc is small, and the potential for restrike is negligible.

When this system is used on distribution systems, it becomes difficult to provide a good match with system changes and switching, on a regular basis. Furthermore, these systems are seldom transposed and may have many single-phase taps, all of which result in small zero-sequence voltages that are generated by the normal load currents. These voltages act in a series resonance circuit with the grounding reactor and shunt capacitance and may produce a high voltage across the reactor and capacitance. The system must have full line-to-line insulation. Experience has shown that a large number of line-to-line faults may occur, and there can be a higher incidence of simultaneous faults. When used, a very sensitive overcurrent relay provides an alarm and, after about 10–20 sec, if the fault still exists, the reactor is shorted out. This provides a high ground-fault current to operate in other relays to isolate the fault. It is not used in the United States, although there may be one or two older applications, which are still not converted to other grounding methods.

The application of this technique to grounding unit generators is more favorable because of the short distances and fixed value of system capacitance involved. With the very low fault current, it is promoted as permitting the continued operation of the generator with a ground fault until an orderly convenient shutdown can be arranged. After 45 years of experience on some 20 unit generators, several generator cable problems, and one generator ground fault, 25% from the neutral, have been detected. In the last instance the generator remained online for 89 min with minimal copper and no iron damage. However, there is a concern for the elevated voltages on the unfaulted phases should there be a solid ground fault at the terminals.

7.5.2 HIGH-RESISTANCE GROUNDING

In this system the power system is grounded through a resistor, and the accepted practice is to use a value of resistance equal or slightly less than the total system capacitance to ground. This provides a low fault current to minimize damage, yet limits the potential transient overvoltages to less than 2.5 times the normal crest value to ground. The fault current range normally encountered with this method is between 1 and 25 A primary, which is usually between 1 and 10 A.

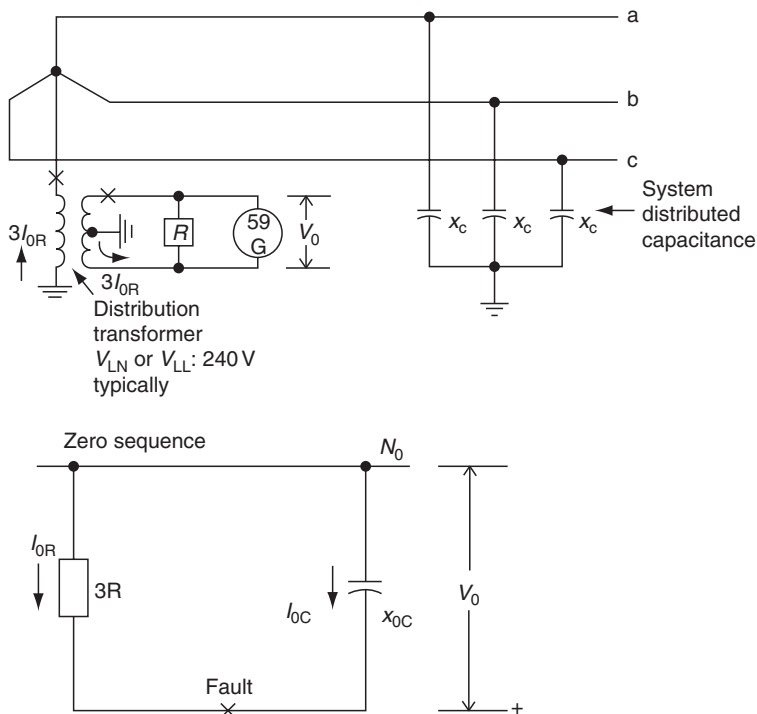

FIGURE 7.9 High-resistance grounding with resistor in the neutral.

The grounding resistor may be connected in the neutral of a generator or power transformer (Figure 7.9), or across the broken delta of line-to-ground-connected distribution transformers (Figure 7.10). With the resistor in the neutral, as in Figure 7.9, a solid ground fault can produce a maximum V_0 equivalent to the phase-to-neutral voltage as illustrated in Figure 7.1. Thus a line-to-neutral-rated distribution transformer is normally used, although line-to-line ratings have also been used. For the grounding system similar to that indicated in Figure 7.10, a solid ground fault can raise the voltage on two of the distribution transformers to line-to-line equivalent (see Figure 7.1). Thus, line-to-line ratings are suggested for this application, especially if the protection system is used for alarm, rather than direct trip.

The neutral connection (see Figure 7.9) is used for unit generator applications and in industrial systems with a single power transformer supply. For multiple generators connected to a common bus or for systems with several power sources, the grounding system of Figure 7.10 may be preferable. These two methods are best documented by typical examples.

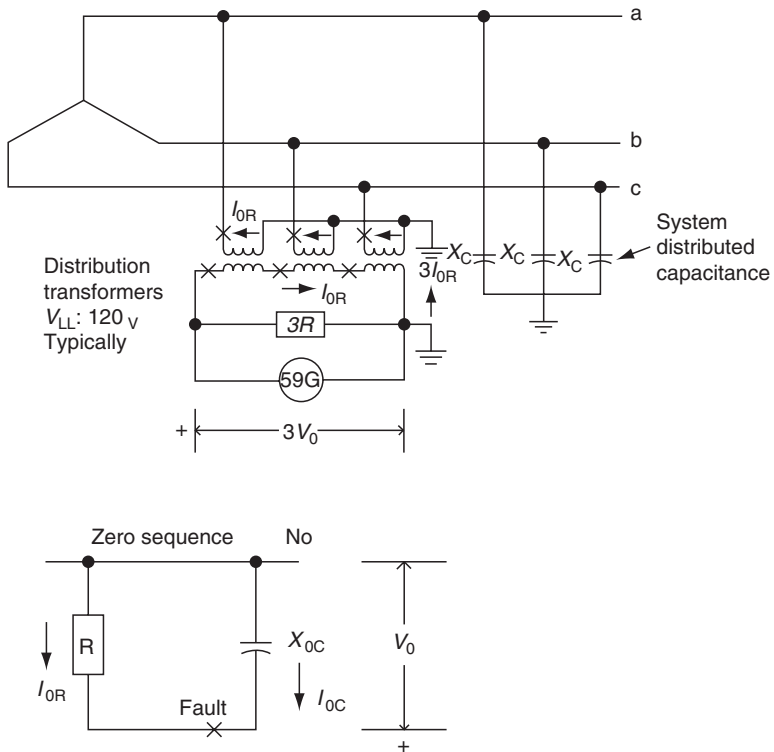
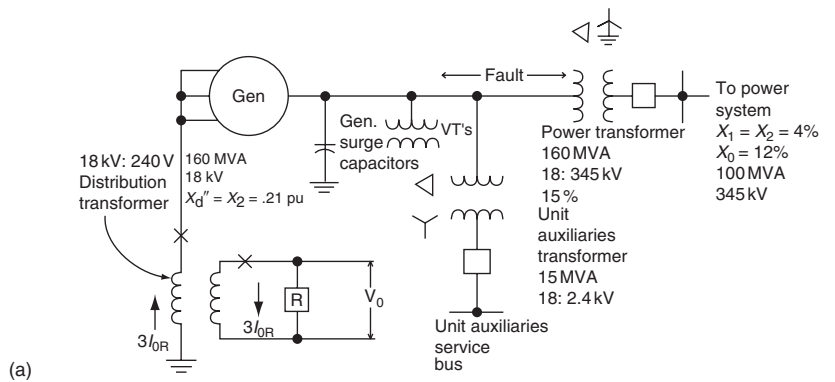

FIGURE 7.10 High-resistance grounding with resistor across distribution transformer secondaries.

7.5.3 EXAMPLE: TYPICAL HIGH-RESISTANCE NEUTRAL GROUNDING

This type of grounding is applied to a 160 MVA 18 kV unit generator, as shown in Figure 7.11. The area of ground protection is the generator to the low-voltage winding of the power transformer and to the high-voltage winding of the unit auxiliary transformer. In this area the following capacitances to the ground (microfarads per phase) must be considered:

Generator windings	0.24
Generator surge capacitor	0.25
Generator-to-transformer leads	0.004
Power transformer low-voltage winding	0.03
Station service transformer high-voltage winding	0.004
Voltage transformer windings	0.0005
	<hr/>
Total capacitance to ground	0.5285



(a)

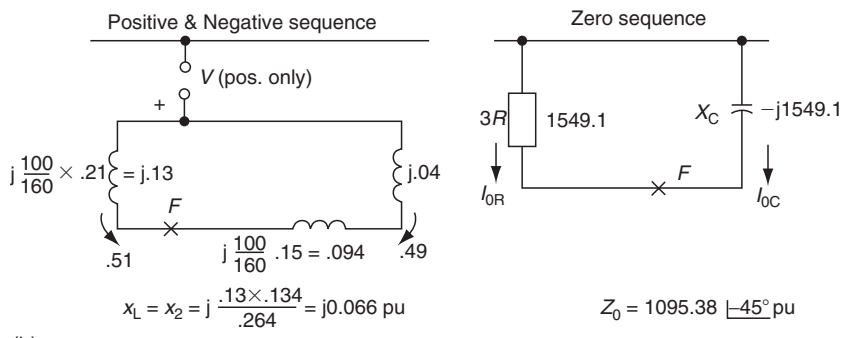

(b)

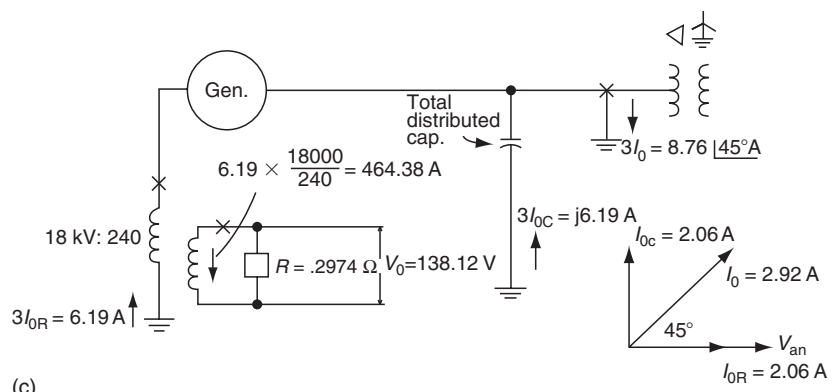

(c)

FIGURE 7.11 Typical example of high-resistance grounding with neutral resistor: (a) unit generator system; (b) sequence networks, values in per unit at 100 MVA, 18 kV; (c) fault current distribution.

$$X_C = -j \frac{10^6}{2\pi f C} = -j \frac{10^6}{2(3.1416)(60)(0.5285)} = 5019.08 \Omega/\text{phase}. \quad (7.11)$$

This capacitive reactance, in per unit on a 100 MVA 18 kV base, is from [Equation 2.15](#),

$$\frac{100(5019)}{18^2} = 1549.1 \text{ pu} \quad (7.12)$$

or on the generator MVA base, $160(5019)18^2 = 2478.56 \text{ pu}$. Selecting the grounding resistor to be equal to the capacitive reactance and using the convenient 100 MVA base, $3R$ in the zero-sequence network would be 1549.1 pu. For a solid fault in this area,

$$Z_0 = \frac{1549.1(1549.1 \angle -90^\circ)}{1549.1 - j1549.1} = 1095.38 \angle -45^\circ \text{ pu}.$$

In contrast, the positive- and negative-sequence reactance for this system is $j0.066 \text{ pu}$ and, therefore, quite negligible. From [Equation 7.1](#) and [Equation 7.2](#),

$$I_1 = I_2 = I_0 = \frac{1.0}{1095.38 \angle -45^\circ} = 0.00091 \angle 45^\circ \text{ pu}, \quad (7.13)$$

$$1.0 \text{ pu} = \frac{100,000}{\sqrt{3} \times 18} = 3207.5 \text{ A at 18 kV}, \quad (7.14)$$

so the fault currents are

$$I_1 = I_2 = I_0 = 0.00091(3207.5) = 2.92 \text{ A at 18 kV}, \quad (7.15)$$

$$I_a = 3I_0 = 3(2.92) = 8.76 \text{ A at 18 kV}. \quad (7.16)$$

The distribution of these fault currents is shown in [Figure 7.11](#). The resistor that is selected with its primary resistance $3R$, which is equal to X_C , provides a value of $5019.08/3 = 1673.03 \Omega$ at 18 kV. The actual resistor value connected to the secondary of the distribution transformer will be

$$R = 1673.03 \left(\frac{240}{18,000} \right)^2 = 0.2974 \Omega. \quad (7.17)$$

With a secondary current of $6.19(18,000/240) = 464.38 \text{ A}$ in the distribution transformer secondary, the V_0 that is available for a primary line-to-ground fault will be

$$V_0 = (464.38)(0.2974) = 138.12 \text{ V.} \quad (7.18)$$

The number of watts in the resistor during the fault is

$$\frac{(464.38)^2(0.2974)}{1000} = 64.14 \text{ kW.} \quad (7.19)$$

Similarly, the distribution transformer kilovolt–ampere (kVA) is

$$6.19 \left(\frac{18}{\sqrt{3}} \right) = 64.33 \text{ kVA,}$$

which is equal within decimal-point accuracy. When this grounding is used for generator units, tripping the unit is recommended, so that these ratings can be short-time ratings, rather than continuous ratings.

The normal charging current for this system would be

$$I_C = \frac{18,000}{\sqrt{3} \times 5019} = 2.07 \text{ A/phase at 18 kV.} \quad (7.20)$$

The use of a distribution transformer and a secondary resistor, rather than a resistor directly connected in the neutral, is an economic consideration. With high-resistance grounding it is generally less expensive to use the resistor in the secondary, as shown.

The flow of current through the system for a ground fault is sometimes hard to visualize from the zero-sequence quantities, such as that shown in [Figure 7.11](#). Although positive- and negative-sequence impedances are quite negligible in high-resistance grounded system, the three-sequence currents are equal at the fault ([see Equation 7.13](#)) and flow through the system. Since there is a positive-sequence source at either end as shown in [Figure 7.11](#), the positive- and negative-sequence currents divide, as shown by the 0.51 and 0.49 distribution factors in the positive- and negative-sequence networks. The approximate currents flowing through this system are documented in [Figure 7.12](#). They are approximate, for the capacitance normally distributed is shown as lumped. Before the fault, a charging current of 2.07 A ([see Equation 7.20](#)) flows symmetrically in the three phases. Because this is the same order of magnitude as the fault currents, Thevenin's theorem and superposition must be used to determine the currents flowing during the ground fault. Thus, in phase *a* from the generator to the lumped capacitance, I_{a1} is the sum of the prefault charging current and the fault component, or $2.07 \angle 90^\circ + 0.51 \times 2.92 \angle 45^\circ$ which is $I_{a1} = 3.29 \angle 71.4^\circ$. Similarly, $I_{b1} = 2.07 \angle -30^\circ + 0.51 \times 2.92 \angle -75^\circ = 3.29 \angle -48.7^\circ$ and $I_{c1} = 2.07 \angle 210^\circ + 0.51 \times 2.92 \angle 165^\circ = 3.29 \angle 191.41^\circ$.

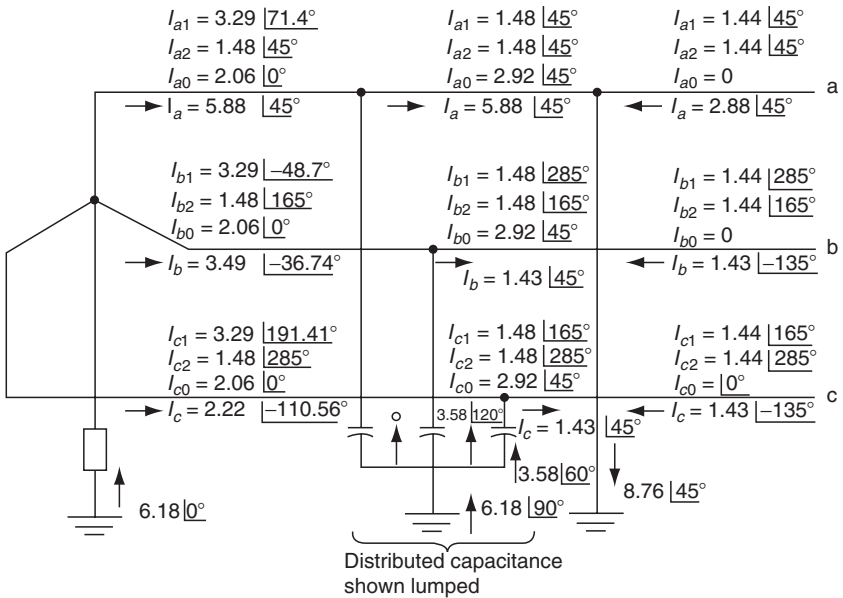

FIGURE 7.12 Three-phase and sequence current distribution for the system of [Figure 7.11](#) during a solid phase-*a*-to-ground fault.

The negative- and zero-sequence components exist as normally determined by the fault. In the lumped shunt capacitance, the charging current of 2.07 A cancels the zero-sequence phase *a* component of 2.07 A to provide zero current, because this branch is essentially shorted out by the solid phase-*a*-to-ground fault. In the unfaulted phases the charging currents add to the zero-sequence component, providing currents as shown in [Figure 7.12](#). [Figure 7.12](#) is similar and consistent with [Figure 7.2](#). The source voltage for [Figure 7.2](#) is $1/\underline{90^\circ}$, whereas for [Figure 7.12](#) it is $1/\underline{0^\circ}$.

Again, this assumes that none of the distributed capacitance is in the area to the right of the fault location. As has been indicated, the total fault value would not change for different fault locations; similarly, the distribution will not change basically, for no series impedance is considered between the generator and the power transformer.

7.5.4 EXAMPLE: TYPICAL HIGH-RESISTANCE GROUNDING WITH THREE DISTRIBUTION TRANSFORMERS

An industrial plant 13.8 kV system is illustrated in [Figure 7.13](#). The main source is the utility, but the plant has a small local generator. Either the supply transformer or the generator could be grounded with a resistor in the neutral (if the supply transformer is wye secondary), but it is possible that

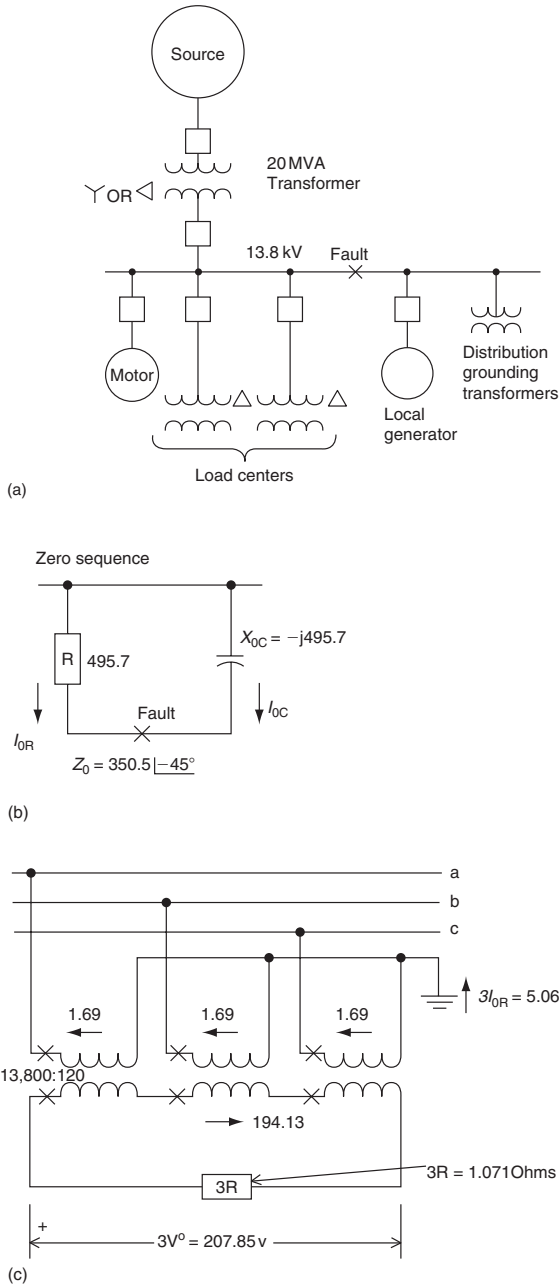

FIGURE 7.13 Typical example of high-resistance grounding with three distribution transformers: (a) industrial system; (b) zero-sequence network, values in per unit on 20 MVA, 13.8 kV; (c) ampere currents flowing for the ground fault.

either the local generator or the utility supply may be out of service. Thus, this system is to be grounded using the method shown in [Figure 7.10](#).

From estimating data or specific tests, we have the following capacitances to ground (microfarads per phase):

Source transformer	0.004
Local generator	0.11
Motor	0.06
Power center transformers	0.008
Total connecting cables	0.13
Surge capacitor	0.25
<hr/>	
Total capacitance to ground	0.562

$$X_C = -j \frac{10^6}{2\pi fC} = -j \frac{10^6}{2(3.1416)(60)(0.0562)} = 4719.9 \Omega/\text{phase}. \quad (7.21)$$

Thus, the charging current of this 13.8 kV system is

$$I_C = \frac{13,800}{\sqrt{3} \times 4719.9} = 1.69 \text{ A/phase at } 13.8 \text{ kV}. \quad (7.22)$$

The total capacitance in per unit on a 20 MVA 13.8 kV base is from [Equation 2.15](#)

$$X_C = \frac{20(4719.9)}{13.8^2} = 495.68 \text{ pu}. \quad (7.23)$$

For high-resistance grounding (see [Figure 7.10](#)), $R = X_{0C}$, so R in the zero-sequence network is 495.68 pu. For the system

$$Z_0 = \frac{(495.7)(-j495.7)}{495.7 - j495.7} = 350.5 \angle -45^\circ \text{ pu}. \quad (7.24)$$

For a line-to-ground fault the positive- and negative-sequence values of the system are very small and can be ignored. Thus, for a line-to-ground fault on this 13.8 kV system,

$$I_1 = I_2 = I_0 = \frac{1.0}{350.5 \angle -45^\circ} = 0.00285 \angle 45^\circ \text{ pu}. \quad (7.25)$$

The base per unit current is

$$I_{\text{base}} = \frac{20,000}{\sqrt{3} \times 13.8} = 836.74 \text{ A at } 13.8 \text{ kV}. \quad (7.26)$$

Thus,

$$I_1 = I_2 = I_0 = 0.00285(836.74) = 2.39 \text{ A at } 13.8 \text{ kV}, \quad (7.27)$$

$$I_a = 3I_0 = 0.00856 \text{ pu} = 7.16 \text{ A at } 13.8 \text{ kV}, \quad (7.28)$$

$$I_{0R} = 0.00285 \cos 45^\circ = 0.00202 \text{ pu} = 1.69 \text{ A at } 13.8 \text{ kV}. \quad (7.29)$$

The three distribution transformers have the ratio 13.8 kV:120 = 115. Thus, the secondary current for the ground fault is

$$I_{0R(\text{sec})} = 1.69(115) = 194.13 \text{ A}. \quad (7.30)$$

The resistor was sized at 495.68 pu or 4719.9 Ω at 13.8 kV. Reflected to the secondary, the resistor value becomes

$$3R = 3 \times \frac{4719.9}{115^2} = 1.071 \text{ } \Omega \text{ secondary}. \quad (7.31)$$

This is the resistance value for installation. Alternatively, this value can be calculated directly from the system values:

$$\begin{aligned} 3R &= \frac{(\sqrt{3}V_{\text{sec}})^2}{2\pi fC(V_{\text{Pri LL}})^2} = \frac{(\sqrt{3} \times 120)^2}{377(0.562)(13.8)^2} \\ &= 1.071 \text{ } \Omega \text{ secondary}, \end{aligned} \quad (7.32)$$

$$3V_0 = 194.13(1.071) = 207.85 \text{ V secondary}, \quad (7.33)$$

The continuous resistor and transformer ratings are

$$\text{Resistor: } I^2(3R) = \frac{(194.13)^2(1.071)}{1000} = 40.36 \text{ kW}. \quad (7.34)$$

$$\text{Transformer: } VI = \frac{1.69(13,800)}{1000} = 23.3 \text{ kVA}. \quad (7.35)$$

The line-to-line voltage was used during a fault; this voltage appears essentially across the primary winding. If relays are used to trip, short-time ratings may be used for the resistor and transformers.

7.6 SYSTEM GROUNDING FOR MINE OR OTHER HAZARDOUS-TYPE APPLICATIONS

A medium-high-resistance grounding system was developed originally for underground coal mining systems and is being used more and more for all

mining and hazardous-type applications. In view of the great hazardous conditions often encountered in mining, these systems emphasize on personnel safety and limit the fault current to 25–50 primary amperes. A typical system is shown in Figure 7.14. All portable equipment in the mine is fed by a separate feeder that is resistance-grounded, separately at a location at least 50 ft from the supply substation. Many applications limit the ground current to 25 A primary amperes. This separate ground is carried as a fourth wire with

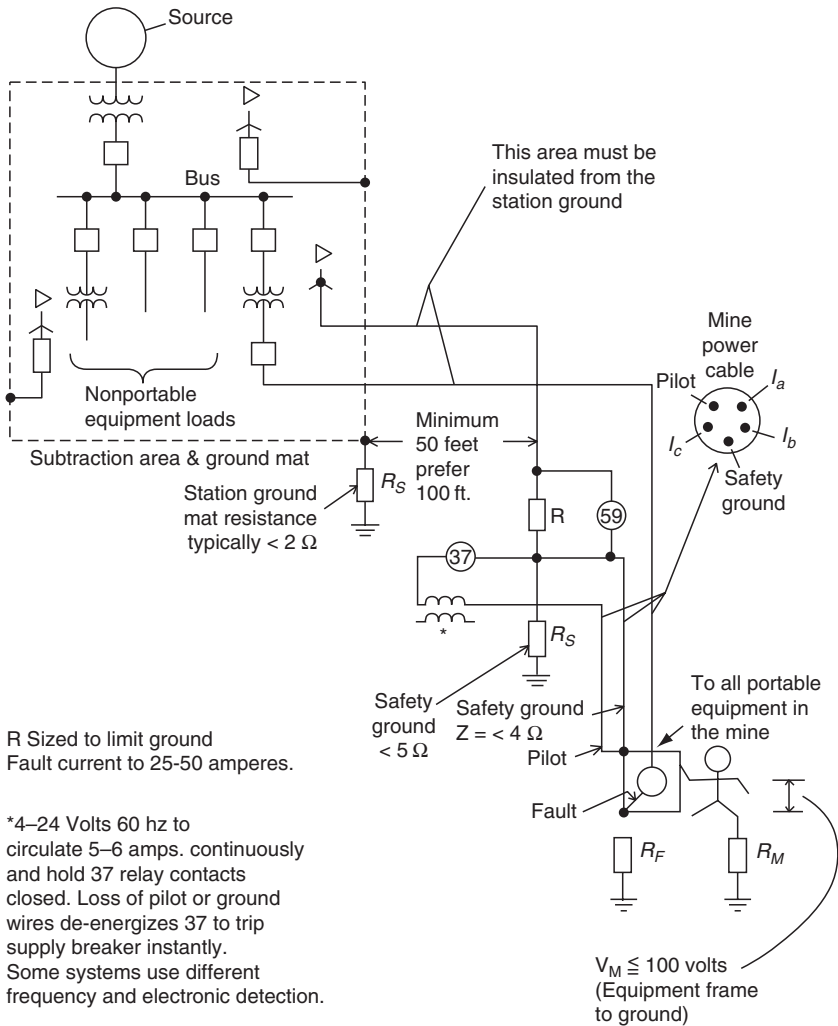

FIGURE 7.14 Typical system grounding for mining or other hazardous applications.

its impedance not to exceed 4Ω . A pilot conductor is also carried in the supply cable with a monitoring system to assure continuity of this ground. For a ground fault to frame at the portable equipment, 25 A current, flowing over the 4Ω safety ground wire would produce a maximum of 100 V across the operator. A very fast, sensitive relay is used to detect a ground fault and instantly trip off this feeder, without concern for fault location. With high hazard potentials, safety concerns override selectivity and continuity of service. All essential loads, such as lighting, fans, and vital support services, are fed from normal feeders from the substation.

7.7 LOW-IMPEDANCE GROUNDING

The low-impedance-grounding limits line-to-ground fault currents to approximately 50 to 600 A primary. It is used to limit the fault current, yet permit selective protective relaying by magnitude differences in fault current by the power system impedances. There are also cost advantages because line-to-neutral equipment insulation can be used, for the unfaulted phase voltages are not increased significantly by the ground faults.

Most typically, this type of grounding is accomplished by a reactor or resistor in the system neutral (Figure 7.15). In a distribution station it would be in the neutral of the delta-*we*ye supply transformer. Several generator units that are connected to a common bus may be grounded in this manner. The zero-sequence network for this is also shown in Figure 7.15.

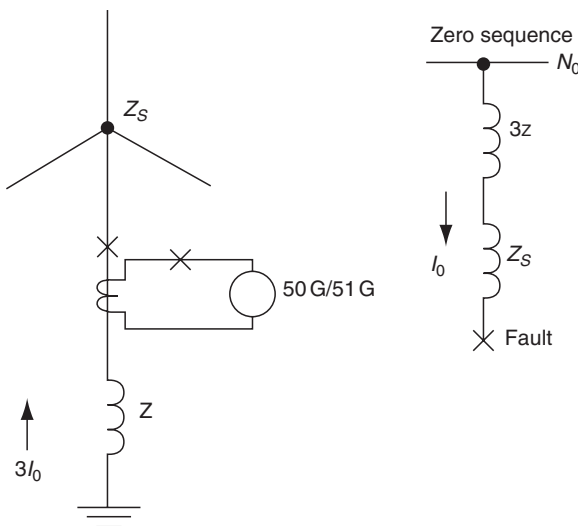

FIGURE 7.15 Low-impedance grounding with impedance in the system neutral.

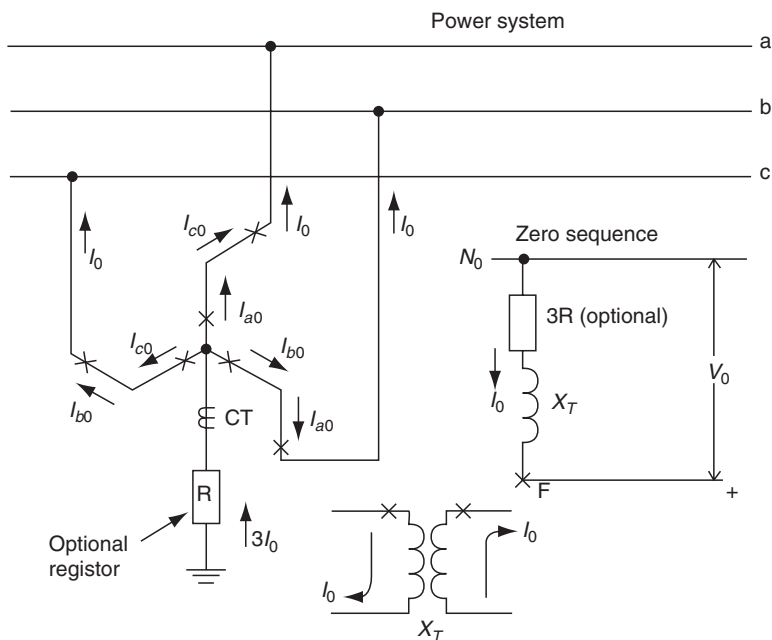

FIGURE 7.16 Low-impedance system grounding with a zigzag grounding transformer.

When a delta-connected transformer exists, or a system-neutral is unavailable, this type of grounding can be accomplished either by a shunt connection of a wye-grounded–delta transformer or by a zigzag transformer. The wye-grounded–delta transformer could be applied only for grounding purposes and not for transmitting power. The grounding would be as just indicated and shown in Figure 7.15.

The zigzag transformer is illustrated in Figure 7.16. Basically, this unit consists of three 1:1 ratio transformers interconnected to pass zero-sequence current only. With the transformer polarities shown and because $I_{a0} = I_{b0} = I_{c0} = I_0$, zero-sequence current can flow, but positive- and negative-sequence currents cannot because $I_{a1} \neq I_{c1} \neq I_{b1}$ and $I_{a2} \neq I_{b2} \neq I_{c2}$. The impedance of the zero-sequence path is the leakage impedance of the transformer X_T . With a line-to-neutral voltage of 1 pu, the voltage across each winding is 0.866 pu. The zigzag transformer grounding is reactance, as the transformer resistance is very low. If the zigzag X_T is too low for the desired fault limiting, a resistor (or reactor) can be added as shown.

7.7.1 EXAMPLE: TYPICAL LOW-RESISTANCE NEUTRAL REACTOR GROUNDING

The grounding reactor in the typical system of Figure 7.17 is to be applied to limit the maximum line-to-ground fault current to 400 A primary. For convenience a 20 MVA base is used for the calculations. From Equation A 4.1-4:

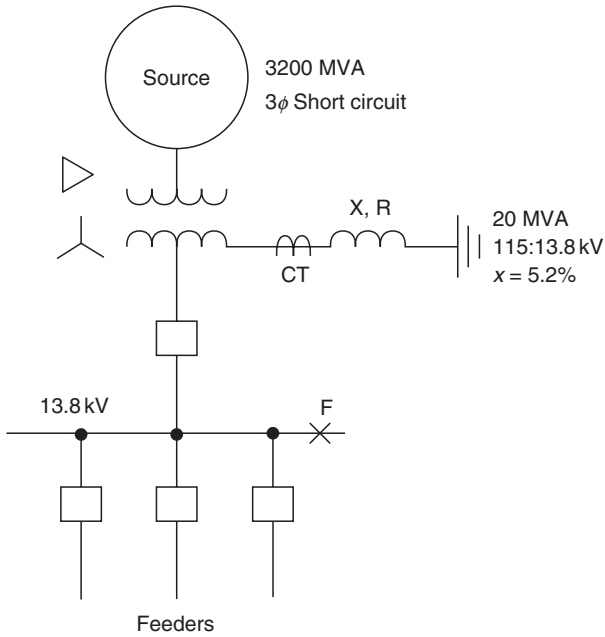

FIGURE 7.17 Typical example of low-impedance grounding.

$$\text{Source: } X_1 = X_2 = \frac{\text{MVA}_{\text{Base}}}{\text{MAV}_{\text{SC}}} = \frac{20}{3200} = j0.00625 \text{ pu.} \quad (7.36)$$

$$\text{Transformer: } X_T = j0.052 \text{ pu.} \quad (7.37)$$

$$\text{Total: } X_1 = X_2 = j(0.0063 + 0.052) = j0.0583 \text{ pu.} \quad (7.38)$$

$$\text{Total: } X_0 = j(0.052 + 3X) \text{ pu.} \quad (7.39)$$

For a 400 A primary fault:

$$I_1 = I_2 = I_0 = \frac{400}{3} = 133.33 \text{ A at 13.8 kV,} \quad (7.40)$$

$$I_{\text{Base}} = \frac{20,000}{\sqrt{3} \times 13.8} = 836.74 \text{ A,} \quad (7.41)$$

$$I_1 = I_2 = I_0 = \frac{133.33}{836.74} = 0.159 \text{ pu,} \quad (7.42)$$

$$X_1 + X_2 + X_0 = j(0.1685 + 3X), \quad (7.43)$$

$$0.159 = \frac{j1.0}{j(0.1685 + 3X)}, \quad (7.44)$$

$$\begin{aligned}
 X &= 2.036 \text{ pu} \\
 &= \frac{13.8^2(2.036)}{20} = 19.38 \Omega \text{ at } 13.8 \text{ kV (see Equation 2.17)}. \quad (7.45)
 \end{aligned}$$

7.7.2 EXAMPLE: TYPICAL LOW-RESISTANCE NEUTRAL RESISTANCE GROUNDING

The grounding resistor is to be applied in the typical system of Figure 7.17 to limit the maximum line-to-ground fault current to 400 A primary. As for the previous example, $X_1 = X_2 = j0.0583$, but with a resistor,

$$Z_0 = 3R + j0.052 \text{ pu.}$$

In addition, as before, 400 A for a line-to-ground fault represents an $I_1 = I_2 = I_0$ of 0.159 pu from Equation 7.42. Thus,

$$I_1 = I_2 = I_0 = 0.159 \angle ?^\circ = \frac{j1.0}{3R + j0.1685}. \quad (7.46)$$

This is best solved by the sum of the squares, so rearranging yields

$$\begin{aligned}
 3R + j0.1685 &= \frac{j1.0}{0.159 \angle ?^\circ}, \\
 (3R)^2 + (0.1685)^2 &= (6.29)^2, \\
 R = 2.09 \text{ pu} &= \frac{13.8^2(2.09)}{20} = 19.91 \Omega \text{ at } 13.8 \text{ kV}. \quad (7.47)
 \end{aligned}$$

Comparing the values 19.38 (see Equation 7.45) for a reactor and 19.91 (see Equation 7.47) for a resistor shows that in many cases with resistor grounding, the angle can be ignored and the resistor can be added arithmetically, rather than vectorally. This simplifies the calculations, generally with little error. Thus, from a practical standpoint, where the resistor value is large compared with the system reactance or impedance, its value can be calculated directly as

$$R = \frac{V_{LN}}{I} = \frac{13,800}{\sqrt{3} \times 400} = 19.92 \Omega. \quad (7.48)$$

7.8 SOLID (EFFECTIVE) GROUNDING

Effective grounding is defined by ANSI/IEEE standards (IEEE 100) when the power system constants are

$$\frac{X_0}{X_1} \%3.0 \quad \text{and} \quad \frac{R_0}{X_1} \%1.0, \quad (7.49)$$

where X_0 and R_0 are the zero-sequence reactance and resistance and X_1 the positive-sequence reactance of the power system. Practically, this indicates that there can be no impedance between system neutral and ground; hence, these systems are solidly grounded. Usually, this is accomplished by connecting the neutral of the wye windings of the power transformer(s) to the station ground mat and ground. In the diagrams this would be shown as in [Figure 7.15](#) or [Figure 7.17](#), with X, R omitted. As a result the ground-fault currents can vary considerably, from very small currents to currents greater than the three-phase-fault value. The magnitudes depend on the power system configuration and constants, location of the fault, and the fault resistance, which may or may not be significant. Because the current level can vary with the fault location, it becomes easier to locate the fault and selectively isolate the trouble area by protective relays. The various techniques used are covered in the various chapters on equipment protection. The CTs shown in the grounded neutral in [Figure 7.15](#) through [Figure 7.17](#) are used to operate time-overcurrent relays that are set sensitively and with time to coordinate with the various lines, feeders, and so on, relays that they “overreach.” Hence, this serves as backup—“last resort” protection for ground faults around the areas that are not properly cleared by their primary and associated backup protection.

7.8.1 EXAMPLE: SOLID GROUNDING

Assume that the transformer bank of the system of [Figure 7.17](#) is solidly grounded ($X, R = 0$). For a fault at F , $X_1 = X_2 = j0.0583$ pu (see [Equation 7.38](#)) and $X_0 = j0.052$ pu, which are all on a 20 MVA 13.8 kV base. Thus, $X_1 + X_2 + X_0 = j0.1685$ pu and

$$\begin{aligned} I_1 = I_2 = I_0 &= \frac{j1.0}{j0.1685} = 5.934 \text{ pu} \\ &= 4965.8 \text{ A at 13.8 kV}, \end{aligned} \quad (7.50)$$

$$I_a = 3I_0 = 17.8 \text{ pu}, = 14,897.8 \text{ A fault current at 13.8 kV.} \quad (7.51)$$

This is more than 37 times larger than the 400 A low-impedance grounded example.

For a three-phase fault at F:

$$\begin{aligned} I_1 &= \frac{j1.0}{j.0583} = 17.17 \text{ pu}, \\ &= 14,364.6 \text{ A at 13.8 kV.} \end{aligned} \quad (7.52)$$

Thus, the ground-fault current is larger than the current for a three-phase fault. The difference in this example is small because the source is quite large compared with the supply transformer. If the source impedance was larger, the two fault currents would be lower, but the ground fault would be at a larger percentage of the three-phase fault.

Figure 7.17 is a typical distribution transformer that is connected to a very large power system source. Thus, relatively the source impedance is very low compared to the distribution transformer. For a three-phase fault on the bus

$$I_{3\phi} = \frac{1}{X_1} \text{ pu}, \quad (7.53)$$

$$I_{\phi g} = \frac{1}{(2X_1 + X_0)} \text{ pu, where } X_1 = X_2. \quad (7.54)$$

If the source impedance is neglected, then $X_0 = X_1 = X_2$ and

$$I_{3\phi} = I_{\phi g} = \frac{1}{X_1} \text{ pu.}$$

If the source impedance is included, then X_1 and X_2 are greater than X_0 and $I_{\phi g}$ is greater than $I_{3\phi}$, as in the foregoing example (see Equation 7.51 and Equation 7.52).

If X_0 is greater than X_1 , X_2 as will occur for faults out on the feeders, because line X_0 is generally about 3–3.5 X_1 , then

$$I_{\phi g} = \text{is less than } I_{3\phi}.$$

With the possibility of very low ground fault currents out on long rural or urban feeders that are difficult or impossible to isolate, solid grounding of the distribution transformers is recommended to provide as much ground fault current as possible for detection by the relays.

7.8.2 GROUND DETECTION ON SOLID-GROUNDED SYSTEMS

Fault current at any given location on solidly grounded systems will vary with fault location, such that overcurrent protection generally can be applied. This is in contrast with ungrounded and high-impedance grounded systems for which the current level does not vary significantly over the network.

Thus, zero-sequence voltage is used as a reference for ground directional units and is obtained with wye-grounded–broken-delta voltage transformers in Figure 7.5, for a solid phase-*a*-ground fault where $V_{ag} = 0$, then from Equation 7.9

$$V_{pg} = 3V_0 = V_{bg} + V_{cg} = 1 - 30^\circ + 1 - 150^\circ = -j1 \text{ pu.} \quad (7.55)$$

Thus, the maximum $3V_0$ for a solid fault is V_{LN} , whereas for the ungrounded system it is $3V_{LN}$.

7.9 FERRORESONANCE IN THREE-PHASE POWER SYSTEMS

Ferroresonance now appears to be occurring more frequently in power systems, especially in distribution systems. Thus, a review is in order because it relates to power system grounding. This is a complex nonlinear phenomenon occasioned by the system capacitance resonating with the nonlinear magnetizing (exciting) reactance of connected transformer(s). It is characterized by sustained, but variable, overvoltages with very irregular wave-forms and appreciable harmonics. The magnitudes are sufficient to damage the equipment connected.

A detailed discussion of this phenomenon is beyond our scope; therefore, the intent is to present a brief overview of typical possibilities that can lead to potential hazards. The possibility of ferroresonance with voltage transformers in ungrounded power systems has been outlined in [Section 7.4](#).

In source-grounded distribution systems, it is generally practiced to connect the load transformers with their primaries ungrounded. A typical system is shown in [Figure 7.18a](#). Often, the distribution circuit is overhead, with fuse cutout or single-phase disconnect switches on the pole. From this point, cable is run underground to a pad-mounted transformer near the utilization point. Several possibilities exist in these circuits for ferroresonance at light load or no load on the secondary.

In [Figure 7.18b](#), energizing phase *a* before phases *b* and *c* provides a path for current flow, as indicated by the arrows. The nonlinear exciting reactance of the transformers is in series with the system capacitance to ground. With the common delta primary, transformers *ab* and *ac* are energized at 0.577-rated voltage, so that exciting current or, if energized at or near the zero point on the voltage wave, magnetizing inrush currents flow. With residual flux in the transformer core, this can result in a large current. At the end of the half-wave the transformer core drops out of saturation, but a trapped charge or voltage is left on the cable capacitance. During the following half-cycle the polarity of the source voltage and trapped charge of the cable capacitance are the same and can force the core into saturation in the opposite direction.

As the core goes in and out of saturation, in either a random or a periodic manner, high overvoltages appear between the phases and phase-to-ground. These can be on the order of 5 pu or higher. When a second phase is energized, the overvoltages can continue and may become larger. Energizing the third phase eliminates the single-phase condition and usually the ferroresonance.

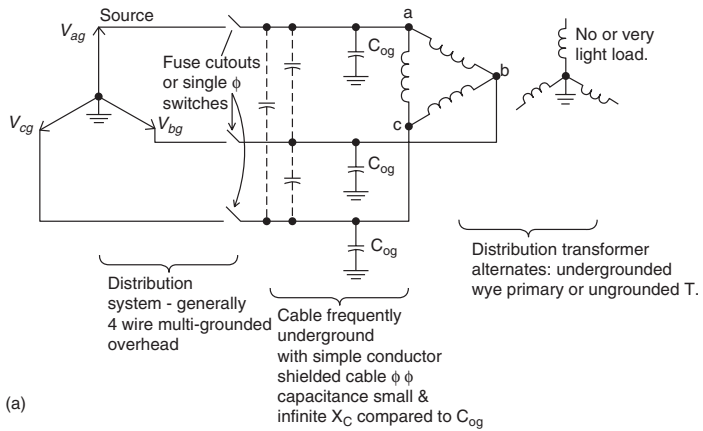

(a)

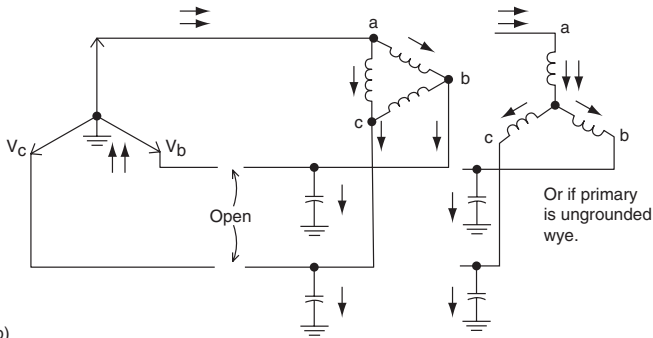

(b)

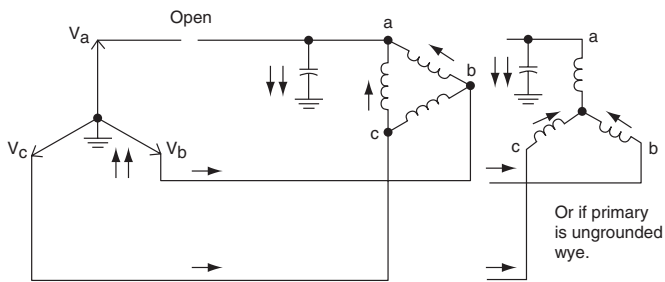

(c)

FIGURE 7.18 Ferroresonance possibilities with ungrounded transformers connected to grounded power system: (a) typical distribution system; (b) ferroresonance current paths when one phase (phase a) is energized before the other phases, or if two phases are opened by fuse, breaker, or switch operation; (c) ferroresonance current paths when one phase (phase a) opens by a blown fuse, broken conductor, defective breaker or switch.

Similarly, the capacitance-to-ground and exciting reactances have the possibility of being in resonance for a broken fuse, broken conductor, and so on, where one phase is open as illustrated in [Figure 7.18c](#).

To limit the voltage on the open phase to about 1.25 pu or less,

$$\frac{X_C}{X_e} \geq K, \quad (7.56)$$

where X_C is the equivalent capacitive reactance per phase and X_e is the equivalent exciting reactance. K has been indicated to be 40, although few others think that it should be in the range of 5–10. In terms of the system, Equation 7.56 can be expressed as

$$\frac{X_C \text{ kVA}}{10^5 \text{ kV}^2} (I_e)^K. \quad (7.57)$$

From this it can be observed that, in general, ferroresonance is more prone to occur

1. With smaller-sized transformers. Ferroresonance can occur in small transformers in 25 kV and 35 kV systems, resulting from the internal capacitance of the transformer and the transformer exciting reactance.
2. At higher voltages, of about 15 kV and above.
3. With long cable runs or circuits with high capacitance.

For single-conductor cables with shields, the typical capacitance values are about 0.25–0.75 (average 0.5) $\mu\text{F}/\text{mi}$, in comparison to the open-wire line values of 0.01 $\mu\text{F}/\text{mi}$. Thus, the capacitive reactance of underground cables is only about 2% of the capacitive reactance of an overhead circuit.

Whereas the probability of ferroresonance is low for systems operating at 15 kV or less, examples have been reported of ferroresonance in 15 kV systems with long cable runs. It is more probable in systems of 25 kV and 35 kV that are using cable. It is generally unlikely to occur if the primary windings are grounded-wye or grounded-tee, especially if the transformers are three, independent single-phase units or of the three-phase triplex type, where there is no magnetic coupling or negligible coupling between the phase windings, and with single-conductor shielded cable, where the interphase capacitances are very large. However, ferroresonance can occur with

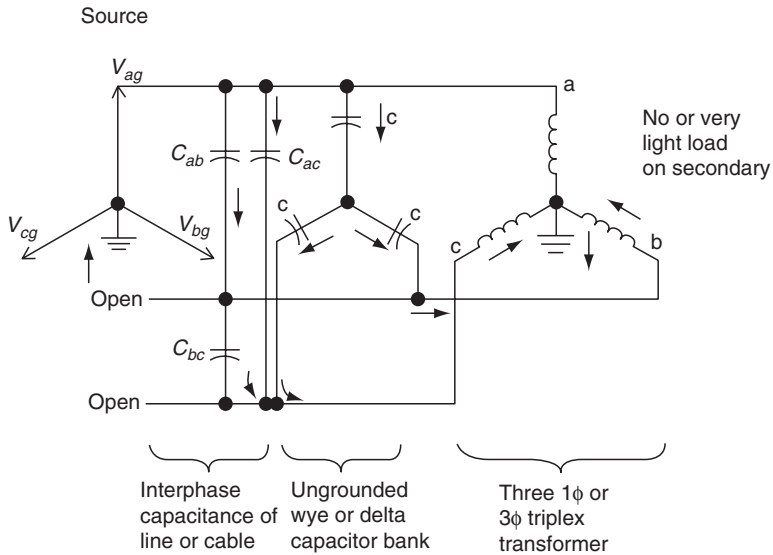

FIGURE 7.19 Ferroresonance possibilities with grounded transformers resulting from interphase capacitance on long circuits or with ungrounded shunt capacitor banks.

grounded-wye transformers, as shown in Figure 7.19, either through the interphase capacitance on a long line, or three-conductor cable, or through ungrounded shunt capacitor banks.

It can also occur when four- and five-legged core transformer banks (Figure 7.20) are used. There is magnetic and capacitive coupling between the three phases. This magnetic coupling between the phases with the phase-to-ground capacitive reactance on the open phases provides a series-parallel

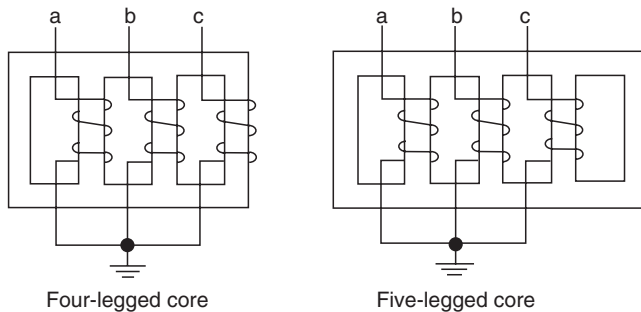

FIGURE 7.20 Three-phase transformer banks with four- and five-legged cores provide magnetic and capacitive coupling paths between the three phases that can contribute to ferroresonance.

circuit that can resonate in a nonlinear manner. The magnitude of the overvoltages reported for this type is <2.5 pu, in contrast with 5 pu; and higher for the ungrounded transformers.

7.9.1 GENERAL SUMMARY FOR FERRORESONANCE FOR DISTRIBUTION SYSTEMS

There is far from an exact science, so the foregoing discussion is very general. In practice, there are many circuits with very little capacitive reactance or extremely high-capacitive reactances, relative to the exciting reactances, that ferroresonance and high voltages will not occur when one or two conductors are open. Also, resistive load on the secondary of the transformers, on the order of 5%–15% of the transformer rating, should prevent ferroresonance.

Where ferroresonance may occur with ungrounded transformers that are supplied by cable, possible solutions are three-phase switching or switching closer or at the bank. Both of these can be expensive or impractical in many applications. Only switching with load can help, but, however, may not always be practical and does not prevent the blown-fuse or broken-conductor problems that could occur at light load. The application of transformers with grounded primaries and minimum interphase coupling generally should provide a solution.

7.9.2 FERRORESONANCE AT HIGH VOLTAGES

Ferroresonance is not limited to distribution, but can occur almost anywhere in the power system. As an example, sustained 60 and 20 Hz ferroresonance has been experienced in a parallel 13 km 500 kV line where one end of each line connects without a breaker to separate 750 MVA grounded wye–delta tertiary autotransformer banks. This randomly occurred in the line when it was de-energized by opening the 500 kV breaker at one end and the autotransformer secondary 230 kV breaker at the other end, with the parallel line still energized. The ferroresonance circuit is the 500 kV line capacitive reactance to ground and the exciting reactance of the 500 kV autotransformer winding to ground. The mutual couplings between the two lines, which are on the same tower, provide the voltages for this phenomenon. The tertiary was essentially unloaded, so the solution to avoid future problems was to load down the tertiary. Calculations indicated that about 590 kW was supplied to the ferroresonant circuit from the energized line and that about an additional 250 kW by the 28 kV tertiary was sufficient to damp the oscillations.

Ferroresonance can occur between line capacitance and line shunt reactors after a long line is de-energized. This is shown in [Figure 7.21](#) for a 500 kV line. Phase *b* has severe ferroresonance, whereas the other two phases “ring” as the trapped energy is dissipated.

Another case is shown in [Figure 7.22](#). This was ferroresonance that occurred between the voltage transformers inductance and the breaker-grading

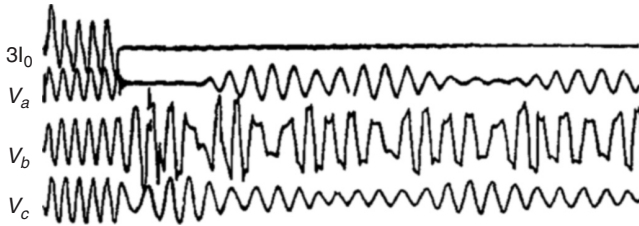

FIGURE 7.21 Ferroresonance on a de-energized 500 kV line between the line capacitance and line reactors.

capacitors when a section of a 345 kV ring bus was opened before the closing of line-sectionalizing switches to reconnect the line to the bus. Overvoltage on phase *c* lasted 15 min until the sectionalizing switches were closed. Some 4 months later this VT failed. Secondary resistance was added to the VT secondaries during switching operations to prevent this problem.

7.10 SAFETY GROUNDING

Power stations and substations for either utilities or industrial plants are built on ground mats. These are carefully designed to provide minimum voltage drops across mat in all directions (step and touch potentials) and minimum impedance between mat and true earth or remote ground (ground potential rise). The primary aim is to reduce and minimize electric shock potentials for personnel safety. These designs are a specialized field and are beyond our scope of discussion. Standard IEEE 80 is the basic guide for this area.

All equipment frames within the ground-mat area in these stations must be solidly bonded to the mat. This includes all exposed metallic parts of relays, relay switchboards, fences, secondary wiring, and so on. Thus, all secondary circuits from the CTs and VTs are grounded. There should be only *one* ground in the circuit, and the general practice favors grounding at the switchboard or relay house. Multiple grounds may short-out relay(s) and prevent proper clearing of a fault, and may cause secondary wiring damage. A ground in the yard and another in the switch-house place the secondary wiring in parallel with the ground mat, so that part of the heavy fault current can directly flow in the secondary winding to either damage related facilities or cause a misoperation. Only one ground in the circuit is sufficient to minimize any electrostatic potential.

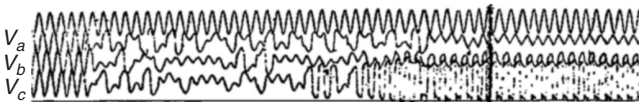

FIGURE 7.22 Ferroresonance on a de-energized section of a 345 kV ring bus between the voltage transformer inductances and the breaker-grading capacitors.

If any equipment cannot be properly grounded, it should be carefully isolated from all contact with the concerned personnel. Special care must be taken for equipment that is associated with both the station and the remote ground (transfer potential). Communication channels can fall into this category and are discussed in greater detail in [Chapter 13](#).

Electromagnetic induction should be minimized by design with the station. Two grounds are required to reduce this hazard; again, the technique is discussed in [Chapter 13](#). In areas involving electrical equipment where a ground mat is not possible or practical, safety must be carefully examined. The fundamentals of the problem are illustrated in [Figure 7.23](#). Although many diverse factors are involved, it appears that the average or reasonable resistance of a human being is from 1000 to 2000 Ω foot-to-foot and 500 to 1000 foot-to-arm, and these limits are general. R_F can be made small by a low-impedance ground wire (fourth wire or third wire in a single phase) that is effectively and adequately connected to ground with minimum impedance.

R_M can be made large by high insulation to ground (nonwet) and by avoiding moist earth or possible contact with metallic surfaces, such as water pipes that are connected to ground. In addition, sensitive and fast ground protection is helpful.

An application of this is in system grounding for mines (see [Section 7.6](#), [Figure 7.14](#)). In the home front, the ground wire system has been used, but the modern approach is now to make R_E approach infinity through double insulation and other techniques, thus making ground faults more improbable.

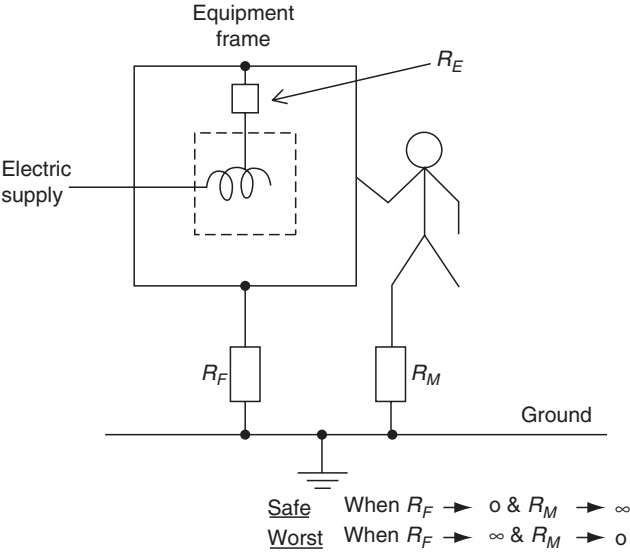

FIGURE 7.23 Basic fundamentals of safety grounding.

7.11 GROUNDING SUMMARY AND RECOMMENDATIONS

A summary of the various grounding methods with suggested recommendations is given in Table 7.2. One column is for industrial and station service electrical systems for large generators in utility power systems. The other column is for all other parts of utility systems. As indicated, there are always

TABLE 7.2
Types of System Grounding and General Recommendations

Types	Approximate Fault current Primary Amperes	Industrial and Utility Station Service Systems	Utility Transmission Subtransmission Distribution	General comments
Ungrounded	Very low	Not generally recommended but used for high-service continuity	Not recommended	<ol style="list-style-type: none"> 1. Faults easy to detect but difficult to selectively locate 2. Fault current low, minimum damage 3. High potential of transient overvoltages 4. Ferroresonance and neutral VT inversion possible 5. Fault maintenance important
High-resistance	1–10	Recommended for high-service continuity	Not recommended	<ol style="list-style-type: none"> 1. Same as above 2. Fault current low, low damage 3. Transient overvoltage limited to $2.5 V_{LN}$
Low-impedance	50–600	Recommended ^a	Not recommended	<ol style="list-style-type: none"> 1. Easier to detect and locate faults selectively
Effective-solid	Low to very high	Recommended ^a	Recommended	<ol style="list-style-type: none"> 1. Easy to detect and selectively locate faults.

^aUp to 1000 V, solid grounding; 1000 V–15 kV, low-impedance grounding; above 15 kV solid grounding.

many factors that influence the grounding choice, therefore, any recommendations can be changed with very valid logic. Thus, the recommendations in [Table 7.2](#) are a guide. Although they reflect the personal opinions of the author, they also generally reflect actual practice in the United States.

For utility systems, only solid grounding is recommended. The logic here is that many distribution circuits extend through public areas and can be fairly long, with taps, branches, and so on. Thus, although the line-to-ground fault at the substation bus will be greater than the three-phase fault, this reverses quickly, as the high-zero-sequence impedance soon becomes predominate. These lower fault currents for faults out on the feeders, along with the probability of high earth-contact resistance at the lower voltages, often makes ground-fault detection very difficult if not impossible. These currents are quite hazardous because of the involvement of presence of the public. Any fault-limiting by neutral impedance tends to increase significantly the difficulty of detecting light faults out on the feeders.

BIBLIOGRAPHY

See Bibliography at the end of [Chapter 1](#) for additional information.

- Cottrell, R.G. and Niebahn, W.D., An analysis of potential ferroresonance at 138 kV distribution substations, *McGraw-Edison's The Line*, 80/2 pp. 9–12, 17–18.
- Forster, R.S. and Beard, L.R., Solving the ferroresonance problem, *Transmission Distribution*, December 1984, pp. 44, 46, 48.
- Gleason, L.L., Neutral inversion of a single potential transformer connected to ground on an isolated delta system, *AIEE Trans.*, 70, P. 1, 1951, pp. 103–111.
- Hopkinson, R.H., Ferroresonant overvoltage control based on TNA tests on three-phase delta-wye transformer banks, *IEEE Trans.*, PAS-86, No. 10, October 1967, pp. 1258–1265.
- Hopkinson, R.H., Ferroresonant overvoltage control based on TNA tests on three-phase wye-delta transformer banks, *IEEE Trans.*, PAS-87, No. 2, February 1965, pp. 352–361.
- IEEE Green Book, Standard 142–1982, Recommended Practice for Grounding of Industrial and Commercial Power Systems, IEEE Service Center.
- IEEE Standard 80, Guide for Safety in AC Substation Grounding, IEEE Service Center.
- Locke, P., Check your ferroresonance concepts at 34 kV, *Transmission Distribution*, April 1978, pp. 32–34, 39.
- Price, E.D., Voltage transformer ferroresonance in transmission substations, Texas A&M University 30th Annual Protection Relay Engineers Conference, April 25–27, 1977.
- Rudenberg, R., *Transient Performance of Electric Power Systems*. MIT Press, Cambridge, MA, 1969.
- Smith, D.R., Swanson, S.R., and Bout, J.D., Overvoltages with remotely-switched cable fed grounded wye–wye transformer. *IEEE Trans.*, PAS-75, September–October 1975, pp. 1843–1853.

8 Generator Protection/Intertie Protection for Distributed Generation

8.1 INTRODUCTION

The nature of generation systems, the locations where they are connected to the power grid, generation ownership, and oversight of generation facilities have changed dramatically over the last 10 years. The evolution that has occurred in these areas was introduced in [Chapter 1](#). These changes have not altered the basic requirements needed to provide good protection for the generator units themselves. These changes, however, have had a significant effect on the range of the size of generators that are connected to and operated in parallel with power systems. Many small units are currently connected to power systems than in the past. Protection requirements need to relate to the value of the equipment protected. As such, protection requirements for large units differ from those for smaller units. Furthermore, the location in the power system at which a generator is connected can create site-specific hazards to the generator as well as to the power system to which it is connected. The information provided in this chapter covers protection requirements for generators in general and for special protection that may be required in some instances at the point of generator/power system inter-connection.

8.1.1 HISTORICAL PERSPECTIVES

When the electric power industry first developed at the turn of the twentieth century, it was characterized by small companies that operated small generators in municipal areas. As the industry quickly grew and evolved, it became clear that its nature was monopolistic in character. Consequently, states formed commissions to provide the required regulations. Subsequently, utilities combined to form large financial holding companies. Because of the large size of these holding companies and the broad geographical territory that was served by the utilities, which were controlled by individual

holding companies, the effectiveness of the state regulatory bodies began to break down. As a result, the federal government became involved in the electric power regulatory process. As a result of unfair manipulation of the electric power market, the large interstate holding companies were forced to divest their holdings. This resulted in the formation of small electric utility companies serving specific geographic areas. Around this time in the 1930s, what is now known as the Federal Energy Regulatory Commission (FERC) was formed for the purpose of regulating interstate electric markets. State commissions were given the responsibility of regulating the various utilities that operated within their borders. This basic structure remained in place until the 1970s. During this period, the power industry was made up mainly of investor-owned utility companies. These utilities sold power generation, transmission, and ancillary services as a bundled product at cost-based rates. States had jurisdiction over retail rates, rate design, and prudence reviews. Regulation for wholesale rates and interstate transmission existed at the federal level. Reliability compliance was voluntary and largely encouraged by peer pressure. The industry itself formed the National Electric Reliability Council (NERC) to perform reliability oversight. Not-for-profit utilities, such as municipal-owned power systems and cooperatives were usually regulated by city or local governmental agencies.

In the above environment, the nature of generating plants evolved into large base-load units designed to take advantage of economies of scale. Generator units installed in the 1960–1980 period typically ranged from 400 to 1200 MVA. Smaller units were usually installed throughout the systems, particularly connected to subtransmission systems, to help serve load during peak load conditions. It was customary to connect the larger units to the high-voltage bulk power transmission system through a high voltage switchyard located at the generating plant.

Since 1978, legislation to promote the deregulation of the power industry has been passed. The main force behind this movement was the desire to create greater efficiency in the industry through the forces of competition. Many felt that a cost-based rate system allowed utilities to expand in a manner that best served their self-interests rather than overall industry efficiency. Deregulation was also felt to be a means to promote the leveling of varying rates that were charged for electricity at different locations throughout the country and as a means to promote the use of technological advances. In 1978, Federal legislation was passed requiring the utilities to purchase power from entities owning cogenerators and generators that utilized renewable-type fuel as a source of energy. In 1992, legislation was passed that allowed generating companies to be exempted from regulation and opened up access to the nation's transmission and distribution systems to any such company. Since 1992, federal restructuring efforts, combined with actions taken at the state level, have completely changed the structure of the electric utility industry in many states. Restructuring has not been uniform across the

country as some states have been reluctant to embrace the new concepts promoted. This reluctance has been caused by a general apprehension about the working of competition in the electric power industry and by disadvantages that such restructuring may produce in states *that* enjoy relatively low electric rates. Problems that have been experienced by some of the states that have pioneered the competition movement, such as California, have reinforced such apprehension.

Currently, the restructuring effort of the electric utility industry is in a state of evolution. Changes are made on a trial-and-error basis with successful systems becoming models for other systems. A clear trend, however, has emerged for the creation of an industry in which generation is unregulated with oversight to help assure that all participants operate on a level playing field. Marketing of electricity is likewise becoming unregulated. Transmission and distribution remains regulated with a trend toward the formation of large-scale entities in the transmission area known as Regional Transmission Owners (RTOs). Oversight for the electric markets and the regulated utilities is provided by federal and state agencies, independent system operators, and independent reliability councils. There is little doubt that additional changes will evolve in the future. Assurance of the reliability of the power systems remains a significant issue at this moment. The changes that have occurred to date have impacted the types of generation placed in service and the manner in which they are connected to the power grid. This, in turn, has created some new hazards to both the generators and the supply system for which protective systems need to be applied. For the purpose of further discussion in this text, generators will be classified as bulk power generators (BPG) and distributed generators (DG).

8.1.2 BULK POWER GENERATORS

BPG are synchronous machines that interconnect into the bulk power transmission system. Such generators are typically above 20 MVA in size and usually range in the 100 to 1200 MVA size. These generators are often located in power plants that may house one or more generating units. The geographic locations of bulk power plants are selected on the basis of factors such as proximity to fuel supply and load centers, availability of a suitable cooling source, and restrictions related to environmental concerns and public acceptance. Most such generating plants are steam plants fueled by coal, oil, gas, and uranium. Bulk power hydro plants are limited to availability of large-scale hydropower. Typical hydro-driven generators are shown in [Figure 8.1](#). These hydrounits have vertical shafts. Steam turbine driven generators have horizontal shafts.

BPG are usually connected to the power system through a high-voltage switchyard located at the plant location. Some smaller bulk power units may tap into a bulk power transmission line, thus effectively creating a three-terminal line.



FIGURE 8.1 Four 100 MVA, 13.8 kV vertical-shaft hydrogenerators. The hydraulic turbines (not shown) are located on the floor below. (Courtesy of Seattle City Light.)

8.1.3 DISTRIBUTED GENERATORS

Distributed generators are made up of induction and synchronous machines. An induction generator is simply an induction motor driven above synchronous speed by a prime mover. Induction generators require a source of excitation, which is typically obtained from the power system to which it is connected. Loss of the power source to the circuit to which an induction generator is connected, therefore, will normally cause the generator to shut down, as its source of excitation is lost. Continued operation of an induction generator is possible after the source to its connected line is removed, however, only if a source of excitation, such as a capacitor bank, exists on the line to which the induction generator remains connected. To sustain operation in a self-excitation state, the amount of excitation, and load that remains isolated with the induction generator must fall within a suitable range.

There are many different types of distributed generation systems along with a variety of ways in which they are connected to the power system. Generators located at industrial plants may be connected to the plant's electrical system electrically at a distance from the point of electrical delivery to the associated industrial complex. Industrial generators may be cogenerators or

backup generators. Cogenerators operate off waste energy produced as part of the industrial process. Backup generators are installed for reliability purposes to maintain service to critical processes in the event of the loss of utility power source. Contractual agreement may allow the industry to operate the backup generator in parallel with the utility source and may in turn allow the industry to sell energy back to the utility.

Other types of distributed generation are powered from a variety of sources such as wind, solar, hydro, biomass, geothermal, urban waste, and conventional fossil fuel. The sizes of such units can also vary from very small single-phase units rated at several kVA to larger units exceeding 100 MVA. Larger distributed generators are usually connected to a subtransmission system. Distributed generators connected to distribution systems are usually limited to units of about 10–15 MVA in size.

8.1.4 POTENTIAL PROBLEMS

BPG and DG share many common hazards. Therefore, protection requirements are similar. Smaller generators, common among DG, warrant less sophisticated protection, however, as their cost is significantly less than large units.

Generator hazards and problems are as follows:

- A. Internal faults
 - 1. Primary and backup phase or ground faults in the stator and associated areas
 - 2. Ground faults in the rotor and loss-of-field excitation
- B. System disturbances and operational hazards
 - 1. Loss of prime-mover; generator motoring (32)
 - 2. Overexcitation: volts or hertz protection (24)
 - 3. Inadvertent energization: nonsynchronized connection (67)
 - 4. Unbalanced currents: negative sequence (46); breaker pole flash-over (61)
 - 5. Thermal overload (49)
 - 6. Off-frequency operation for large steam turbines
 - 7. Uncleared system faults: backup distance (21); voltage controlled time overcurrent (50V)
 - 8. Overvoltage (59)
 - 9. Loss of synchronism: out of step
 - 10. Subsynchronous oscillations
 - 11. Loss of voltage transformer signal to relaying or voltage regulator
 - 12. Generator breaker failure

In the case of DG, additional protection is required at the location where the generator is interconnected to the system. The interconnection location is

commonly referred to as the point of common coupling (PCC). In this text, this protection is referred to as the distributed generation intertie protection. The intertie protection protects the utility system, to which the generator is connected, from harm caused by the generating facility. This protection also serves to protect the generator from events that may originate on the utility power system. Facilities at the PCC will typically consist of protection to prevent islanded operation of the DG and part of the utility system, to assure that (1) the generator does not cause voltage and frequency on the utility system to be outside the acceptable limits, (2) the generator trips for required faults on the intertie line, and (3) faults on the distributed generator system are cleared by the PCC breaker rather than by interrupting devices located on the utility power system. The intertie protection is usually applied at the PCC location, however, in some cases, it may be located elsewhere within the facility of the owner of the DG. In either case, the intertie protection, along with the proposed settings, require the approval of the associated utility and probably of other oversight entities. The utility will also usually require test documentation to assure that the intertie protection is properly constructed, set, and maintained, as the reliability and safety of its system are at stake.

8.2 GENERATOR CONNECTIONS AND OVERVIEW OF TYPICAL PROTECTION

Some common connections for generators are as follows:

1. *Direct connected* (one or several), each through a circuit breaker to a common bus, as illustrated in Figure 8.2. Usually they are wye-grounded through impedance, but may be underground, or are delta-connected. They may be connected to a grounded power system or to the power system through a delta-connected transformer.

Typical protection for DG is shown in [Figure 8.3](#). For such generators under- and overvoltage as well as under- and overfrequency

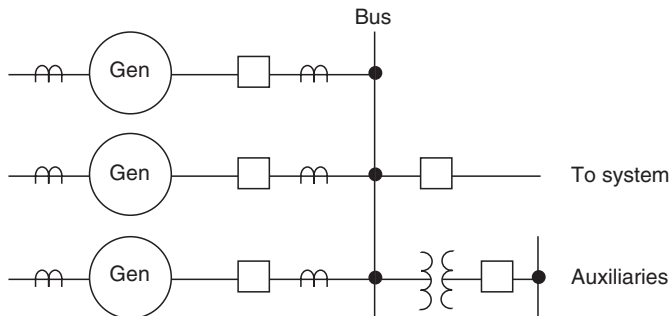

FIGURE 8.2 Direct-connected generator units (one or more) to a common system bus.

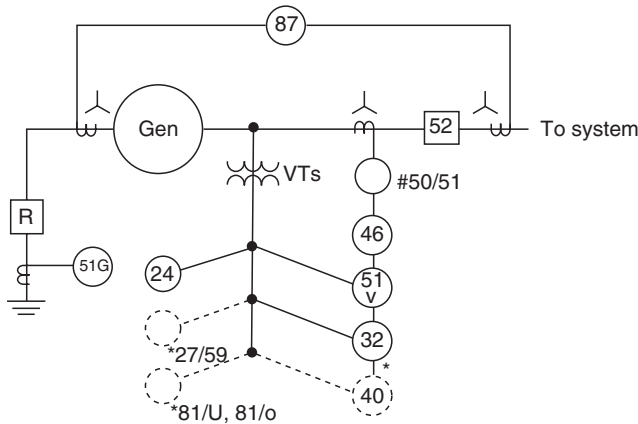

FIGURE 8.3 Typical protection for a direct-connected generator. (*) Dotted relays are optional except 29/57 under- or overvoltage and 81 under- or overvoltage mandatory for nonutility generators connected to a utility; (#50) not always applicable.

relays are applied for disconnecting the power sources from the utility. A separate transfer trip channel from the utility to the distributed unit may be required to assure that the unit is not connected when the utility recloses to restore service. This is important where the DG may be islanded and able to supply the utility loads in the island.

2. *Unit connected*, in which the generator is connected directly to an associated power transformer without a circuit breaker in between, as shown in Figure 8.4. This is the common connection for the large BPG in the utilities. Most generators are wye-connected, with a few delta-connected. These can either be a single generator or two separate generators (cross-compound) that are supplied by a common prime-mover system. Cross-compound generators may have the separate units directly connected together to a single transformer, or connected to separate secondary delta windings of a three-winding power transformer. Generators are also connected to the power system through autotransformers.

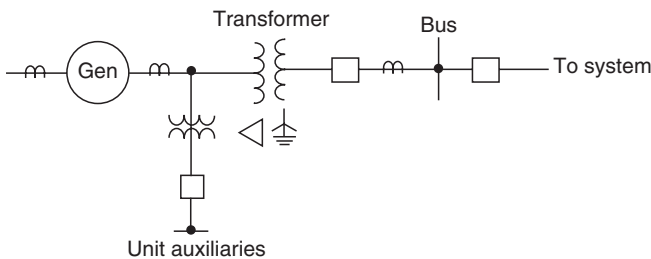

FIGURE 8.4 Unit-connected generator.

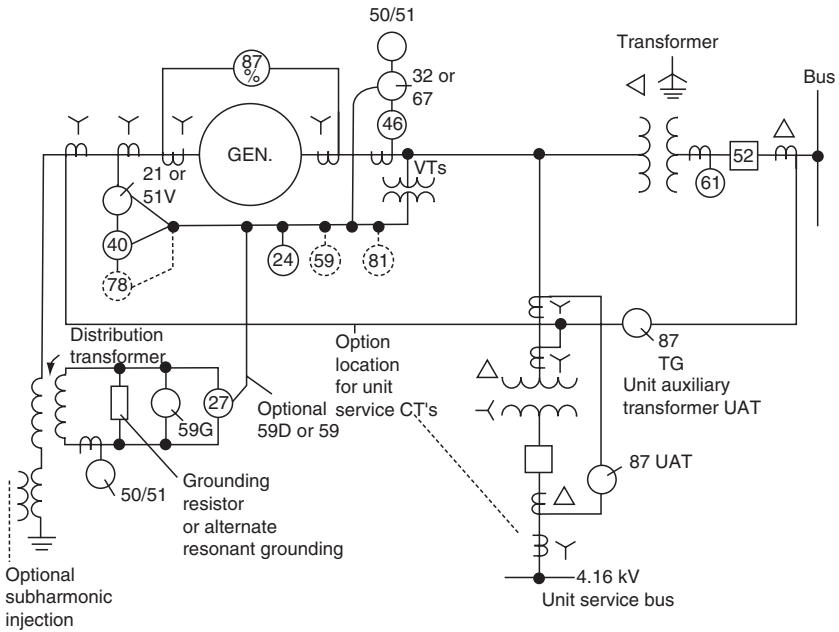

FIGURE 8.5 Typical protection for a unit generator and for large generators in utility systems.

A typical illustration of protection for the unit-connected generator is shown in Figure 8.5. The function and protection of these and other protective units that can be applied on generators are described in the following sections.

The individual protection units shown in Figure 8.3 and Figure 8.5 may be separate relays or may be combined in various combinations. The multifunction digital (microprocessor) relays provide many functions in a single package along with digital fault recording, self-checking, and so on.

8.3 STATOR PHASE-FAULT PROTECTION FOR ALL SIZE GENERATORS

Phase faults seldom occur, but when they do, large fault currents can flow. As indicated in Chapter 6, the best protection is differential (87); consequently, this type is recommended for all generators, except possibly for small units of 1 MVA and less. This provides sensitive protection to phase faults, but may not provide ground fault protection, depending on the type of grounding used, as covered in Chapter 7. The fundamentals of differential protection are outlined in Chapter 6.

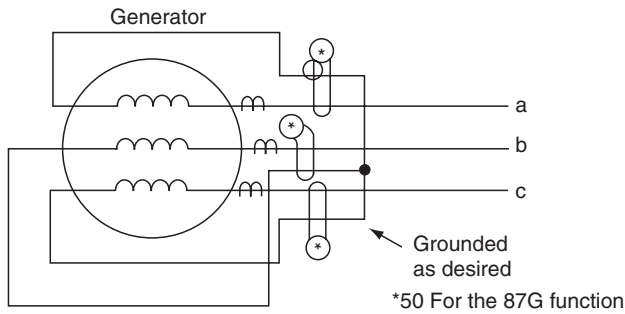

FIGURE 8.6 Differential protection for small generator units with flux summation current transformers and an instantaneous overcurrent (50 relay).

8.3.1 DIFFERENTIAL PROTECTION (87) FOR SMALL kVA (MVA) GENERATORS

The preferred method for small units is shown in Figure 8.6. The limitation is the ability to pass the two conductors through the window or opening of the CT. Typical opening diameters are about 4–8 in. However, where this is possible, high-sensitivity, high-speed protection is obtained, and CT performance does not have to be matched, for there is only one involved per phase. The flux summation CT ratio (commonly 50:5) is independent of generator load current. Typical sensitivities in the order of 5 A primary current can be obtained. This provides protection for both phase- and ground-fault currents as long as the fault level for faults within the differential zone is greater than the sensitivity.

This scheme does not provide protection to the connections from the flux summation CT to the generator breaker, unless the CT is on the bus side of the breaker and the generator neutral side leads are carried to that point. This is seldom practical, so other protection must be provided for this area between the flux summation CT and the breaker. In general, this scheme (see Figure 8.6) is more sensitive as long as the generator CT ratio is greater than 150:5 to 200:5. If the flux summation CT is not applicable and differential protection is desired, the scheme of Figure 8.7 can be used.

8.3.2 MULTI-CT DIFFERENTIAL PROTECTION (87) FOR ALL SIZE GENERATORS

The basic principles of this protection were covered in Section 6.2. It is widely used to provide fast and very sensitive protection to the generator and associated circuits. The 87 relays are connected to two sets of current transformers; one set in the neutral leads, the other in the line side. For

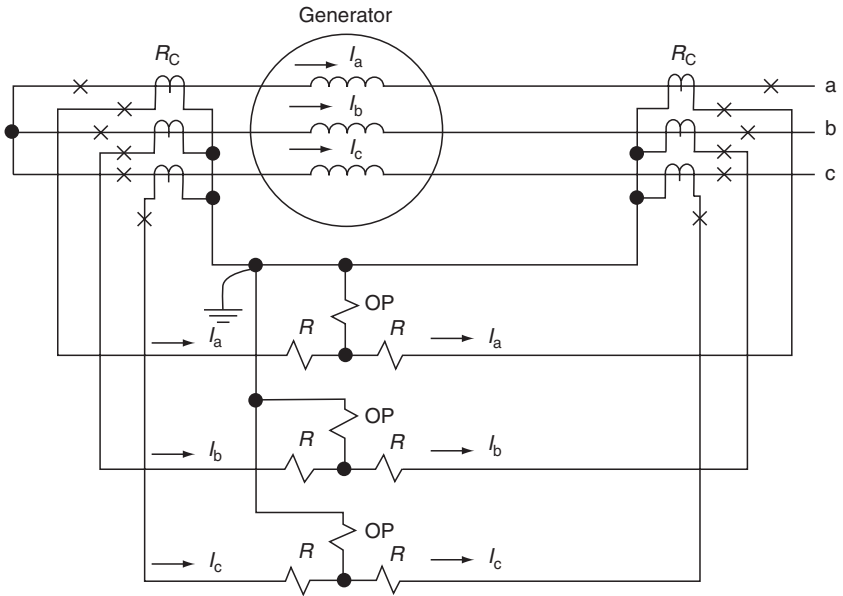

(a)

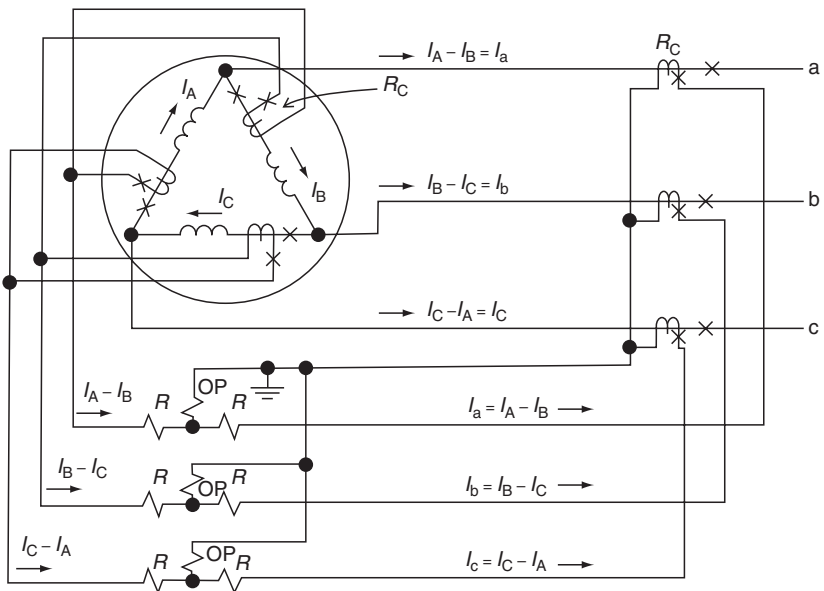

(b)

FIGURE 8.7 Typical differential (87) connections for the protection of wye- and delta-connected generators: (a) wye-connected generator; (b) delta-connected generator.

generators with associated breakers, the line-side CTs are usually associated with the breaker, as shown in [Figure 8.2](#) and [Figure 8.3](#).

For unit generators the line-side CTs are usually quite close to the generator, basically at the generator terminals. Typical connections for the three-phase units are shown in [Figure 8.7](#) for both wye- and delta-connected generators.

If current transformers are available at each end of the windings for the delta-connected generators of [Figure 8.7b](#), the differential relays can be applied for winding protection. The connections would be similar to those shown in [Figure 8.7a](#). However, this would not provide protection for the junction points or the phase circuits that are within the protection zone (see [Figure 8.7b](#)).

Usually, the differential CTs have the same ratio, and they should preferably be of the same type and manufacture to minimize mismatch errors for external faults. This is possible for the unit generators of [Figure 8.4](#) and [Figure 8.5](#), but difficult for those of [Figure 8.2](#) and [Figure 8.3](#), where the CTs in the neutral are one type and those associated with the breaker are another type. It is preferable not to connect any other equipment in the differential circuit and to keep the lead burden as low as possible. Generally, the impedance of the restraint winding of differential relays is low. All this contributes to a totally low-burden and increased performance margins for the CTs.

The application recommendations permit the use of sensitive generator differential relays with low percentage characteristics, typically 10%–25% for the fixed percentage types and the equivalent or lower for the variable types.

Relay sensitivities (pickup current) are near 0.14–0.18 A for the 10% and variable percentage types and about 0.50 A for the 25% types. The operating time should be fast to open the breaker(s), remove the field, and initiate reduction of the prime-mover input. Unfortunately, the flux in the machine continues to supply the fault for several seconds (about 8–16 sec), so instantaneous de-energization of generator faults is not possible.

Problems with magnetizing inrush generally are not severe because the voltage on the machine is developed gradually, and the generator is carefully synchronized to the power system. However, the differential relays should have good immunity to avoid incorrect operation on an external fault that significantly lowers the voltage, which recovers when the fault is cleared. This can cause a “recovery inrush.” This is not applicable to those units that are subject to energizing a transformer or power system at full voltage (black start).

Cross-compound generators have two units, generally connected to a common power transformer. For these units a separate differential relay is applied for each generator unit connected (see [Figure 8.7a](#)).

Split-winding generators, where the two winding halves are available with CTs in one of the halves ([Figure 8.8](#)), can be protected with two separate

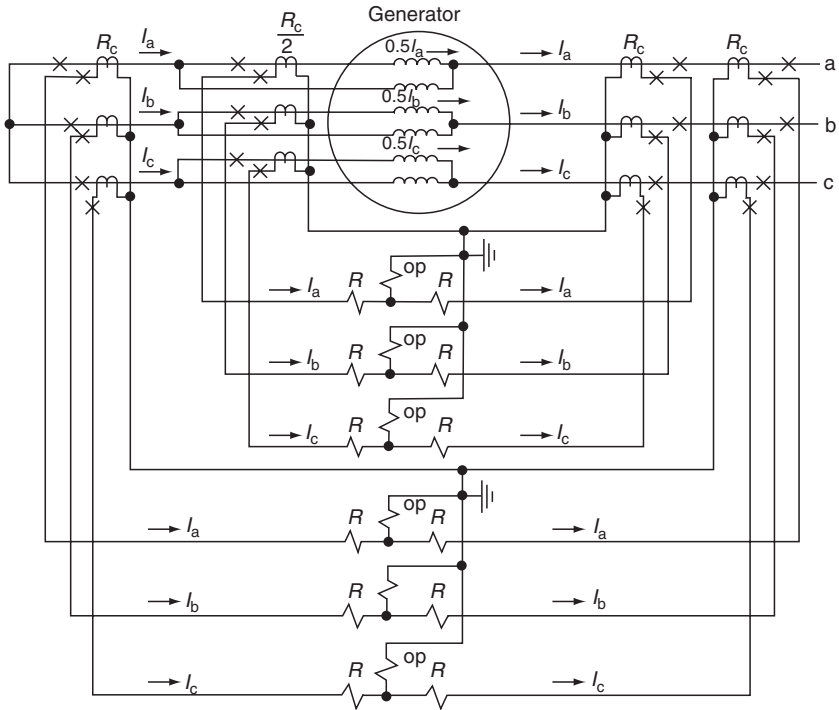

FIGURE 8.8 Typical differential (87) connections for the protection of a split-winding generator.

differentials. By comparing one winding half against the total, as shown, protection for shorted turns and open-circuited windings is possible. This is difficult or impossible for conventional relaying until the fault develops into the other phases or the ground. Where a 2:1 CT ratio is not available, auxiliary CTs can be used.

8.3.3 HIGH-IMPEDANCE VOLTAGE DIFFERENTIAL PROTECTION FOR GENERATORS

The high-impedance voltage type of differential protection scheme can be applied as an alternative to the current differential type described. The relays are connected between phase and neutral leads of the paralleled CTs. For external faults, the voltage across the relay will be low, because the current circulates between the two sets of CTs (see Figure 8.7). For internal faults, the fault currents must pass through the exciting branch and high-impedance relay of each CT, so that the CTs are saturated for most faults,

producing a high voltage to operate the relay. This protection scheme is widely used for bus protection and is described further in [Chapter 10](#). The CT requirements are more or less critical. They should have identical characteristics, negligible leakage reactance, and fully distributed secondary windings.

8.3.4 DIRECT-CONNECTED GENERATOR CURRENT DIFFERENTIAL EXAMPLE

A 20 MVA generator is connected to a 115 kV power system, as shown in Figure 8.9. The 87 differential relays are connected to the generator neutral and circuit breaker CTs. On a 20 MVA base, the equivalent system reactance is $20/100(0.2) = 0.04$ pu. For this, in an internal three-phase fault at F, the total reactance to the fault is

$$X_1 = \frac{0.32 \times 0.14}{0.46} = 0.097 \text{ pu}, \quad (8.1)$$

$$\begin{aligned} I_{30} &= \frac{1}{0.097} = 10.27 \text{ pu at 20 MVA,} \\ &= 10.27 \times \frac{20,000}{\sqrt{3} \times 13.8} = 8593.5 \text{ A at 13.8 kV,} \end{aligned} \quad (8.2)$$

$$I_{\max \text{ load}} = \frac{20,000}{\sqrt{3} \times 13.8} = 836.74 \text{ A at 13.8 kV.} \quad (8.3)$$

Selecting 1000:5 CTs ($R_c = 200$) $I_{\max \text{ load}} = 4.18$ A secondary. With this CT ratio, $I_{30} = 42.96$ A, in the 87 relay-operating coil. This is many multiples of the typical pickup of about 0.4 A for positive and fast operation.

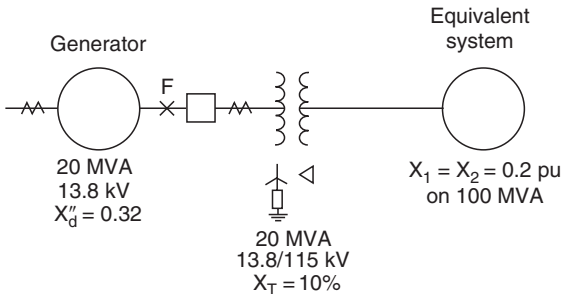

FIGURE 8.9 Example of an ungrounded generator connected to a utility through wye–delta transformer with a ground resistor to limit the ground fault to about 400 A at 13.8 kV.

If the three-phase fault occurred before the generator was synchronized to the power system,

$$\begin{aligned} I_{30} &= \frac{1}{0.32} = 3.13 \text{ pu} = 2614.8 \text{ A at } 13.8 \text{ kV,} \\ &= 13.1 \text{ A through the } 87 \text{ operating coil.} \end{aligned} \quad (8.4)$$

Once again, multiples of pickup are needed for good operation.

The transformer of [Figure 8.7](#) is grounded on the generator side through a 19Ω resistor. This limits the phase-to-ground faults to just over 400 A. For an internal ground fault at F,

$$I_{0g} = \frac{400}{200} = 2.0 \text{ A through the operating coil.} \quad (8.5)$$

With the 87 phase relays set to operate at 0.4 A, the solid ground fault of 2.0 A is five times the relay pickup. Thus, ground fault protection is provided, but should be supplemented with 50N/51N overcurrent relays connected in the grounded neutral.

8.3.5 PHASE PROTECTION FOR SMALL GENERATORS THAT DO NOT USE DIFFERENTIALS

Where small power sources are connected to a large system, protection for phase faults or reflection in the ac circuits of these small sources can be obtained from instantaneous overcurrent (50) or time-overcurrent (51) relays. These are connected in the interconnecting phases to operate on fault currents supplied by the large system. Because these relays are nondirectional, they must be coordinated with upstream devices for which the small generators can supply fault current. This contribution may not exist for some power sources: they usually exist only for a short time for induction generators (see next paragraph) or are relatively small for synchronous generators. In addition, the current supplied by synchronous generators will decrease with time, from subtransient, to transient, to synchronous, as illustrated in [Figure 4.6c](#).

Induction generators need external sources for excitation. When a fault occurs and reduces the voltage, they generally provide a very short-time contribution to faults, as do induction motors (see [Figure 4.6d](#)). If they are islanded with other induction and synchronous machines, it is possible that the system can supply necessary excitation for the induction generator to continue to supply a fault.

Ground relays may also be used if the large system can supply ground fault current. This is dealt with further under the section on ground protection. This protection is not possible to operate if the small generator is ungrounded and if it is not connected to the large system.

8.3.6 UNIT GENERATOR CURRENT DIFFERENTIAL (87) EXAMPLE FOR PHASE PROTECTION

Consider the unit-connected generator tied to a 345 kV power system as shown in Figure 8.10. For a three-phase fault on the 18 kV bus at F_1 , the positive-sequence network is shown and the total reactance to the fault is calculated as

$$X_{1F_1} = \frac{(0.515) (0.485)}{0.255} = 0.064 \text{ pu.} \quad (8.6)$$

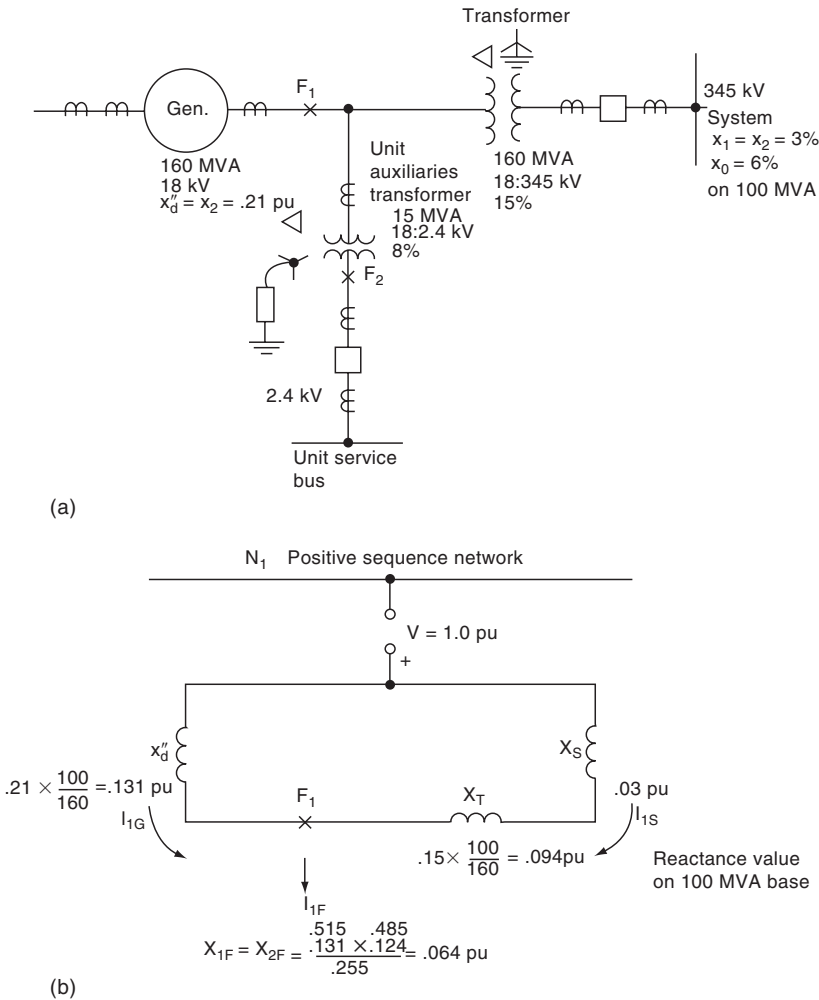

FIGURE 8.10 Typical example of a unit generator (same system as Figure 7.11).

These values are per unit on a 100 MVA base. The values in parentheses define current distribution on either side of the fault. For a solid three-phase fault,

$$I_{1F_1} = I_{aF_1} = \frac{1}{0.064} = 15.70 \text{ pu}, \quad (8.7)$$

$$I_{1 \text{ pu}} = \frac{100.000}{\sqrt{3} \times 18} = 3,207.5 \text{ A at 18 kV}, \quad (8.8)$$

$$I_{1F_1} = I_{aF_1} = 15.7 \times 3207.5 = 50,357.3 \text{ A at 18kV}. \quad (8.9)$$

The maximum load on the unit is

$$I_{\text{max load}} = \frac{160,000}{\sqrt{3} \times 10} = 5,132 \text{ A at 18 kV}. \quad (8.10)$$

From this maximum load, a current transformer ratio of either 5500:5 or 6000:5 could be used. The lowest ratio is preferred for increased sensitivity, so suppose that 5500:5 (1100:1) is used. This gives a full-load secondary current of 5132/1100 or 4.67 A.

The three-phase secondary fault current is

$$I_{1F} = I_{aF_1} = \frac{50,357}{1,100} = 45.78 \text{ A sec}. \quad (8.11)$$

If the fault F_1 is inside the 87 differential zone (see [Figure 8.5](#) and [Figure 8.10](#)) this 45.78 A would flow through the operating coil. This is many multiples of the differential relay pickup current for positive and fast operation.

For the external fault F_1 as shown, the currents through the restraining windings of the differential relay would only be the contribution from the generator, which is

$$I_{1F_1 \text{ gen}} = \frac{50,357.3 \times 0.485}{1,100} = 22.2 \text{ A sec}. \quad (8.12)$$

This would be the internal and total fault current if a three-phase fault occurred before the units were synchronized to the 345 kV system. For these cases the fault current can be calculated alternatively as

$$\begin{aligned}
 I_{1F_1\text{gen}} &= \frac{1.0}{0.131} = 7.62 \text{ pu}, \\
 &= 7.62 \times 3207.5 = 24,438.11 \text{ A at 18 kV}, \\
 &= \frac{24,438.1}{1,100} = 22.2 \text{ A sec.}
 \end{aligned}
 \tag{8.13}$$

8.4 UNIT TRANSFORMER PHASE-FAULT DIFFERENTIAL PROTECTION (87TG)

Furthermore, differential protection is recommended and is shown as 87TG in [Figure 8.5](#). Because there is no breaker between the generator and the transformer, this differential is connected to include the generator, for both the units must be tripped for either transformer or generator faults. This provides added generator protection. Thus, for generator phase faults, 87 and 87TG operate in parallel. In large generator units, an additional differential 87T is sometimes connected around the transformer. Thus, two primary protective systems are provided both for the generator, as shown, and for the transformer (only one 87TG shown). The connections and relays for transformers are discussed in [Chapter 9](#).

In [Figure 8.5](#), the high-side CTs on the unit auxiliary transformer should be included in the 87TG differential, so that faults in the unit auxiliary transformer (UAT) and 4.16 kV system are external. Alternatively, low-side unit auxiliary transformer CTs could be used so that the UAT is within the 87TG protection zone. The same alternatives exist at the location where an added (and recommended) 87UAT differential protection is applied.

It is important to recognize that including the UAT in either the 87TG or 87T zones usually does not provide good or adequate protection for the transformer. This can be demonstrated by considering a solid three-phase fault on the low 4.16 kV side of this bank or at F_2 in [Figure 8.10](#). For this fault the total positive-sequence reactance of the system and the transformer is

$$X_{1F_2} = 0.064 + 0.08 \times \frac{100}{15} = 0.064 + 0.533 = 0.597 \text{ pu}, \tag{8.14}$$

$$I_{1F_2} = I_{aF_2} = \frac{1.0}{0.597} = 1.675 \text{ pu}, = 1.675 \times 3207.5 = 5372.7 \text{ A at 18 kV}. \tag{8.15}$$

In the overall differential, the equivalent CT ratio will be basically close to 1100:1, therefore, with this ratio, the fault F_2 will be $5372.7/1,100 = 4.88 \text{ A}$ secondary. The transformer differential relays are less sensitive because they

must be applied to different types and ratio CTs, avoid operation of magnetizing inrush, and so on. For most relays, this 4.88 A is probably above its minimum pickup, but the low value of fault provides very low multiples of pickup and marginal sensitivity.

This illustrates and emphasizes that a separate transformer differential relay is recommended for the unit auxiliary transformer(s), as shown in [Figure 8.5](#). For this application, the maximum transformer current would be

$$I_{\text{UAT max load}} = \frac{15,000}{\sqrt{3} \times 18} = 481.13 \text{ A at } 18 \text{ kV.} \quad (8.16)$$

Thus, a CT ratio of 500:5 could be used for 87UAT, rather than the equivalent 1100:1 ratio required for 87TG. With an equivalent 500:5 (100:1), fault F_2 would provide an operating coil current of $5,372.7/100 = 53.73$, a good margin for fast and sensitive station transformer fault protection. The 87UAT relays must also shut down the generator and open the 345 kV breaker.

For generators connected as shown in [Figure 8.2](#), the unit auxiliary transformer(s) are connected to the generator bus, usually either with or without a breaker to the bus. A separate differential can be used for the transformer, or without a high-side breaker, include in a bus-transformer differential.

Pressure relays, discussed in [Chapter 9](#), are recommended for all transformers. These supplement differential protection, but can operate only for faults inside the transformer tank.

8.5 PHASE-FAULT BACKUP PROTECTION (51V) OR (21)

Backup protection for the generator and connected system can be provided by a voltage-controlled or voltage-restraint time-overcurrent relay (51V) or by phase distance relays (21). These two types are in wide use, with 51V generally applied to medium and smaller generators, and 21V for large-unit generators.

8.5.1 VOLTAGE-CONTROLLED OR VOLTAGE-RESTRAINT TIME-OVERCURRENT (51V) BACKUP PROTECTION

This is a nondirectional relay; therefore, it can be connected to CTs at the terminal as in [Figure 8.3](#) or at the neutral end as in [Figure 8.5](#). Voltage is from the generator voltage transformers (VTs) and is used to prevent the time-overcurrent unit from operating, until a fault decreases the voltage.

Generators are normally operated close to the knee of their saturation curve. The synchronous reactance-governing load, $X_{d(\text{sat})}$ is a lower value than $X_{d(\text{unsat})}$ for faults that reduce the voltage at the generator. Thus, the sustained three-phase fault current is less than the maximum-load current, as long as the voltage regulator does not increase the sustained fault-reduced voltage.

The voltage-controlled type prevents the overcurrent unit from operating until the fault reduces the voltage to a specific value, typically about 80% of normal. The voltage-restraint type changes the time–overcurrent pickup to decrease with decreasing voltage. Both allow the overcurrent unit to operate at currents below the normal voltage of maximum load. Thus, sustained three-phase current below full load can be detected.

The voltage-controlled type with an adjustable fixed pickup, typically 50% of rated current, is easier to set and coordinate with other relays. On the other hand, the voltage-restraint type is less susceptible to unwanted operations on motor-starting currents and system swings. However, the short-time voltage depression caused by these probably would not result in the time–overcurrent operation.

Generally, the 51V overcurrent unit is connected to one phase with a phase-to-phase voltage for three-phase fault protection. A negative-sequence (46) relay provides protection for unbalanced faults. The 51V must be time-coordinated with any system relays it can overreach.

8.5.2 PHASE-DISTANCE (21) BACKUP PROTECTION

On large generators, especially the unit types, phase-fault backup is usually provided by phase-distance units (21). When connected to CTs on the neutral side, as in [Figure 8.5](#), and set through the generator into the system, backup is provided for both the generator and the system. When using a three-phase type 21 relay, the phase shift of the transformer does not affect the reach, as it does for single-phase-type units. Voltage is obtained from the VTs at the generator terminals.

For distance relays, the location of the CTs determines the directional sensing, whereas distance is measured from the location of the VTs. Thus, if CTs at the generator leads were used, backup could be provided only for the system or for the generator, but not both, depending on the connections. When it is set such that it looks into the system, a fixed timer provides the necessary time delay to coordinate with all the relays its setting overreaches. If it is set such that it looks into the generator, no timer is required.

An alternative connection is to connect the distance relay to CTs and VTs at the generator system bus and set it such that it looks through the unit transformer into the generator. No time delay is required. This provides high-speed backup only for the unit transformer and generator, but not for the connected system.

8.6 NEGATIVE-SEQUENCE CURRENT BACKUP PROTECTION

Negative sequence in a generator crosses the air gap and appears in the rotor or field as a double-frequency current. This tends to flow in the surface of the rotor structure, the nonmagnetic wedges, and other lower-impedance areas.

Severe overheating and, ultimately, the melting of the wedges into the air gap can occur, causing severe damage.

Power systems are not completely symmetrical and loads can be unbalanced so that a small amount of negative sequence is present during normal operation. ANSI standards permit continuous I_2 currents of 5%–10% in generators and also short-time limits expressed as $I_2^2 t = K$, where I_2 is the integrated negative-sequence current flowing for time t in seconds; K is a constant established by the machine design. Typical values for synchronous condensers and older turbine generators were 30–40, but for the very large generators K may be as low as 5–10. Units subject to the specified limit and up to 200% of the limit may be damaged, and early inspection is recommended. For units more than 200%, damage can be expected.

Inverse-time–overcurrent units, operating from negative-sequence current and with a time characteristic adjustable to $I_2^2 t = K$, are recommended for all generators. This protection (46) is shown in [Figure 8.3](#) and [Figure 8.5](#). They are set to operate just before the specified machine $I_2^2 t = K$ limit is reached. A low-level I_2 auxiliary is available, operating typically at about 0.03–0.2 pu I_2 , for warning continued unbalance.

This protection is a backup primarily for unbalanced system faults that are not adequately cleared; it also backs up the protection for the generator unit and associated equipment.

8.7 STATOR GROUND-FAULT PROTECTION

Insulation failure is the major cause of most faults in a generator. They may start as turn-to-turn faults and develop into ground faults, or start as ground faults initially. Thus, ground-fault protection is very important, although fortunately, such faults are relatively rare.

Generator grounding may be one of the three general types.

1. Generator neutral grounded
 - a. Low-impedance (resistor or reactor), normally 50–600 A primary
 - b. High-resistance or resonant, generally 1–10 A primary
 - c. Solid for very small units
2. Generator low-impedance grounded by the connected system, nominally 50–600 A primary
3. Generator and the connected system ungrounded.

Operation of breakers or other disconnecting means can result in category 2 becoming category 3.

Type 1a is widely used for medium and small units and 1b for large bulk power units and critical process industrial generators. Distributed power producers may use all types. Smaller power sources frequently use 1a, 2, or 3, with 1c for some very small sources.

Except for some small generators, the zero-sequence reactance is smaller and more variable than the positive- and negative-sequence values. Thus, solid ground faults will be higher than phase faults. The general practice is to limit ground-fault current by resistance or reactance in the neutrals of the ground connections. The fundamentals of grounding have been covered in Chapter 7.

8.7.1 GROUND-FAULT PROTECTION FOR SINGLE MEDIUM OR SMALL WYE-CONNECTED GENERATORS (TYPE 1A: SEE FIGURE 8.3 AND FIGURE 8.11)

With low-resistance (or reactor) grounding, the 87-phase differential may provide some protection as was illustrated in the example in Section 8.3.4. In these cases, supplemental or backup protection is provided by a time-overcurrent relay 51G in the grounded neutral. Where the differential does not provide protection, the 51G is the primary ground-fault protection. The CT primary rating should be about one-half of the maximum ground-fault current with the 51G set at approximately 0.5 A. Time coordination is necessary with other ground relays that may be overreached. As an alternative, or supplement to 51G, a voltage relay (59G) can be applied. 59G is connected inside the delta of a wye (grounded)–delta auxiliary transformer supplied from VTs connected to the generator terminals. Sensitivity of 59G is similar to that which can be obtained with 51G.

Higher sensitivity and fast operation for ground faults may be obtained by an additional zero-sequence differential. One type that is relatively independent of the CT ratios and CT performance is shown in Figure 8.11. A product-type overcurrent relay, 87GD, operates on the product of the two currents. As

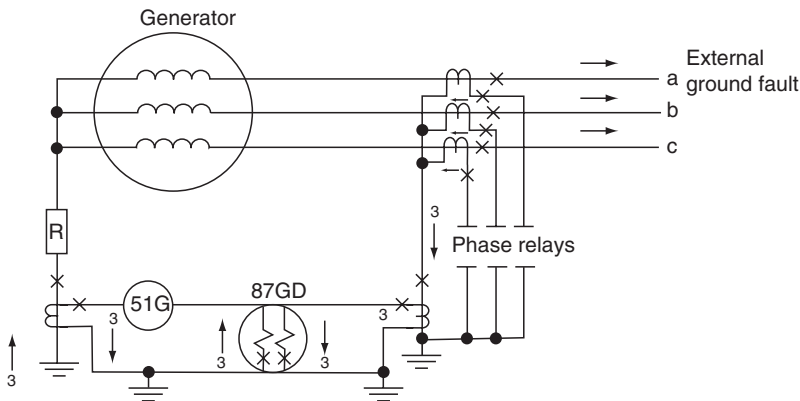

FIGURE 8.11 Ground (zero-sequence) differential protection for a generator using a directional ground-overcurrent relay.

can be seen from the figure, for an external fault the relay currents are in opposition, and the relay does not operate. For internal ground faults, zero-sequence from the system reverses to provide operation. One type of relay has a minimum pickup of 0.25 product or 0.5 A in each coil. With maximum-operating energy with the two currents in phase, the relay will operate with higher currents out of phase $\pm 90^\circ$ and with different magnitudes as long as the product times the cosine of the angle between the currents is greater than the tap product. If the system is not grounded, the scheme, as shown in [Figure 8.11](#), will not operate, because the system does not supply zero-sequence current to the internal fault. In this case, an auxiliary current transformer can be used to provide internal operating energy with only one zero-sequence source. This is discussed in detail in [Section 9.17](#).

8.7.2 GROUND-FAULT PROTECTION OF MULTIPLE MEDIUM OR SMALL WYE- OR DELTA-CONNECTED GENERATORS (TYPE 2; SEE [FIGURE 8.2](#) AND [FIGURE 8.12](#))

When several wye-connected generators are connected to a common bus, such as that indicated in [Figure 8.2](#), it becomes difficult to selectively isolate the fault for minimum system disruption. Whether one or all generator neutrals are grounded similarly, the fault current in the grounded neutrals is basically the same, independent of fault location in the area. That is, for faults in the generator-to-breaker area, on the bus, or in the system just beyond the bus, the fault level in the grounded materials is basically the same. This is true for any of the grounding systems.

With low-impedance grounding and sufficient current to operate the differential relays of the generator and bus, proper minimum isolation can be achieved. Then 51G in the grounded neutrals provides backup or “last resort” protection, which may be nonselective. Another possibility is to apply sensitive ground directional relays set such that it looks into the generator, at the terminals of the generators. These would operate only for ground faults within the machine and not respond to faults in the other machines, bus, or the system. Moreover, 51G in the grounded neutrals provides nonselective backup. This application may be impossible or difficult with high-impedance grounding.

Grounding only one of the generators with an ungrounded system provides the liability of operating as ungrounded when that unit is removed from service either manually or through its protection. Suppose only one unit is grounded, if a ground fault occurs in that grounded unit, a 51G relay (as shown in [Figure 8.3](#)) will provide protection. However, if the fault is in one of the other generators, the grounded generator 51G may operate, but the 51N of the faulted generator would not experience the fault if it is connected to CTs in the neutral side. Thus, multiple grounding of each unit should be used to

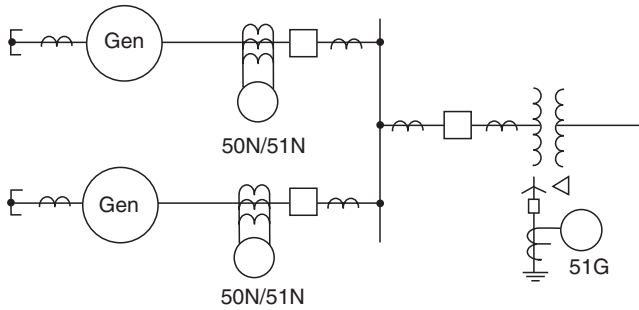

FIGURE 8.12 Ground-fault protection for ungrounded generators grounded by the connected system. Other types of protection, such as in [Figure 8.3](#), are not shown.

avoid ungrounding by fault tripping or a failure to transfer grounding on a planned shutdown of the only grounded unit.

A good method is to ground the main transformer as shown in [Figure 8.12](#), or if this transformer is delta on the generator side, to provide a separate grounding wye–delta transformer connected to the bus and used only for grounding. It would be sized for the fault-limiting as required. 51N/50N ground relays connected to the terminal-side CTs provide ground protection for each unit. 51G in the neutral provides ground protection for the transformer and bus with backup for the 50N/51N relays.

8.7.3 GROUND-FAULT PROTECTION FOR UNGROUNDED GENERATORS

Ground faults in an ungrounded system (type 3) are easy to detect, but are impossible to locate by relays. An overvoltage relay (59) connected across the broken delta of wye–grounded VTs provides $3V_0$ voltage for a ground fault (see [Figure 7.5](#), [Section 7.4.1](#)). This protection should be added wherever the possibility for an ungrounded condition exists by switching or islanding.

8.7.4 GROUND-FAULT PROTECTION FOR VERY SMALL, SOLIDLY GROUNDED GENERATORS

Ground-fault protection is the same as shown in [Figure 8.3](#).

8.7.5 GROUND-FAULT PROTECTION FOR UNIT-CONNECTED GENERATORS USING HIGH-IMPEDANCE NEUTRAL GROUNDING (TYPE 1B: SEE [FIGURE 8.5](#))

High-resistance grounding is widely used for unit-connected generators. The resistor, as discussed in [Section 7.5.2](#), limits ground faults to about 1 to 10 A primary. At these levels a ground fault in the generator will have minimum iron burning to avoid expensive repairs. An overvoltage relay (59G) is connected across the resistor to respond to the V_0 voltage for faults in the

generator and system, up to the delta windings of the unit and station service transformers. The example in Section 7.5.3 (see Figure 7.11) illustrates that, for a solid line-to-ground fault at the generator terminals, the voltage across the resistor will be 138 V, which is quite distinct. The 59G relay with pickup values from 1 to 16 V provides good sensitivity, protecting approximately 90%–95% of generator windings. These relays must be insensitive to third harmonics, which normally flow in the neutral in a manner similar to zero sequence. As indicated in Section 8.7.1, ground fault protection can also be obtained by supplying a 59G relay from the generator voltage transformers.

For resonant-grounding systems (see Section 7.5.1, Figure 7.8), used in a few cases for unit generators, a 59G relay should be applied across the grounding reactor and through a suitable voltage transformer if a primary reactor is used.

With these grounding systems, the sensitive (59G) relays should be coordinated with the voltage transformer's primary fuses. If this is not possible or practical, identify that the unit may be tripped for VT faults. Although these faults are quite possible, the probability is generally very low. Coordination is also important in some applications to avoid misoperation for ground faults on the high-voltage side of the power transformer. This is discussed in a later section.

Frequently, the voltage transformers are wye–wye, but open delta-connected VTs can also be used for three-phase voltage. With wye–wye VTs, the primary wye should be grounded. Unless the secondary is required for zero-sequence indications, the secondary wye should be ungrounded and isolated. Grounding one of the phases provides a safety ground. Otherwise, the 59G may operate for secondary VT circuit ground faults, and 59G should be coordinated with the secondary VT fuses.

Inverse-time instantaneous overcurrent (50/51) relays in the resistor secondary circuit (Figure 8.5) provide alternative or backup ground protection. The secondary CT ratio is selected to give approximately the same relay current as that flowing in the generator neutral for a ground fault. Thus, using Figure 7.11 as an example, a CT ratio of 400:5 (80:1) would offer

$$I_{50/51} = \frac{464.38}{80} = 5.80 \text{ A}, \quad (8.17)$$

where the primary fault current in the neutral would be 6.19 A, which would be reflected through the distribution transformer as 464.38 A.

These relays must be set higher than the maximum unbalance current that normally flows in the neutral circuit. The ideal values are usually less than 1 A in the generator neutral. Settings for 51 should be 1.5–2 times this unbalance. The 50 relay provides instantaneous protection, and it must be set above the normal neutral unbalance as well as above the maximum current resulting from primary system ground faults, whichever is greater. Section 8.7.2

discusses the latter type fault. Typical 51 settings should be two to three times the maximum.

In some applications two 51 relays are used, one to provide backup tripping of the unit, the other to initiate breaker failure relaying (when used) associated with the primary breaker, as shown in [Figure 8.5](#), or breakers if the primary is connected to a ring or breaker-and-half arrangement.

8.7.6 ADDED PROTECTION FOR 100% GENERATOR GROUND PROTECTION WITH HIGH-RESISTANCE GROUNDING

As indicated, the 59G overvoltage across the grounding resistor provides about 90%–95% ground protection for the generator windings. Additional protection is required for ground faults that may occur near the neutral end of the stator winding. Several methods exist and are of two basic types: (1) use of the third-harmonic voltage or (2) the injection of a subharmonic voltage.

1. Normal operation of generators produces harmonics with the third harmonic, the major one. This harmonic behaves similarly to zero-sequence. With the generator connected to delta or ungrounded-wye transformers, the third harmonic cannot pass through the transformer wye-grounded winding and circulate in the delta. Thus, it appears across the ground resistor or across the broken delta-connected VTs normally used for $3V_0$ indications. Typical third-harmonic voltages (V_{180}) are shown in [Figure 8.13](#).
 - a. One protection scheme connects an undervoltage relay (27) responsive to third harmonics in parallel with 59G as shown in [Figure 8.5](#). Its usual closed contact is in series with a voltage-sensing (59) relay connected to the generator VTs. Typical 59 relay settings are about 90% of normal voltage. In normal operation the 27 relay contacts are opened by the third-harmonic normal voltages, and the supervising voltage relay 59 contacts are closed. When a ground fault occurs near the generator neutral the third-harmonic voltage is shorted out, or is significantly reduced to dropout the 27 relay, thus closing its contacts. With the supervising 59 contacts closed an indication of generator 60 Hz voltage, a ground fault is indicated.
 - b. Another scheme applies an overvoltage 59 relay that is responsive to the third harmonics across the broken delta generator VTs. This must be set at a value above the maximum normal third-harmonic voltage. For the neutral-area ground faults, the third-harmonic voltages will be redistributed and increased at the generator terminals. This scheme may offer limited protection when the normal full-load third-harmonic voltage is high, and time coordination is used to avoid operation for higher third-harmonic voltage during external faults.

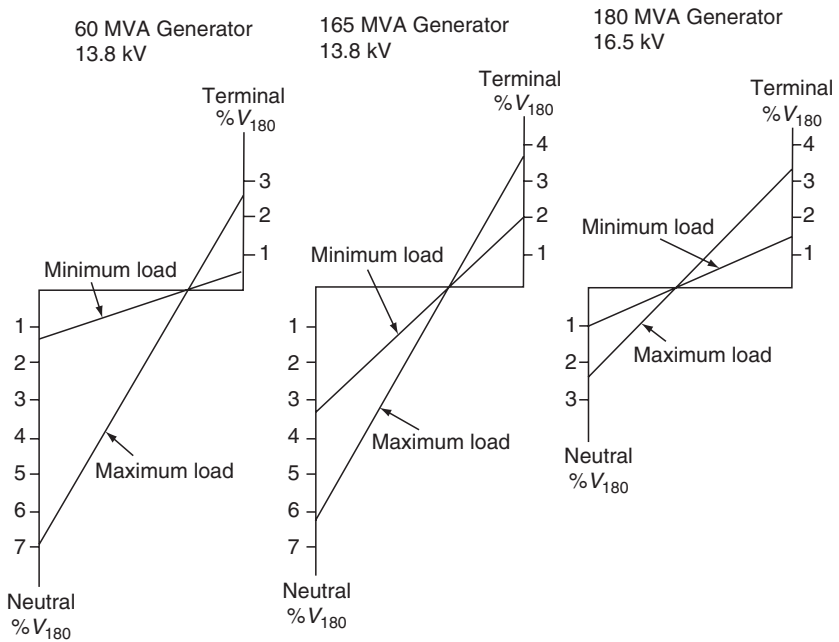

FIGURE 8.13 Third-harmonic phase-to-ground voltages measured on three large generators at maximum and minimum loads. Values in percentage of rated machine phase-to-ground voltage. The left and center generators were hydro and the right a thermal unit.

- c. The third-harmonic voltage at both the neutral and generator terminals can vary considerably from maximum to minimum load. Generally, the third-harmonic voltage at maximum load will be at least 50% greater than at minimum load, with variations of about 2:1 to 5:1. In many cases the ratio of the neutral-to-terminal third-harmonic voltage is reasonably constant with load changes. Therefore, another scheme operates on the differential voltage between the two ends of the winding. Ground faults near the neutral and near the terminals upset the balance, through the fault reducing the third-harmonic voltage at the faulted end. This provides operating overvoltage for relay 59D (see Figure 8.5).

All these schemes require specific data for the third-harmonic voltages over the operating ranges of the generator, for both the real and the reactive power, before the relays can be set properly. One scheme may be more sensitive for one generator, but less sensitive for other generators.

2. The injection of subharmonic frequency current can be by a separate neutral transformer or through the broken-delta VT connection. Some systems provide coding for increased security. A ground fault decreases the generator capacitance to cause an increase in current for detection. These schemes provide the possibility of 100% winding protection and monitoring capability. This neutral or 100% winding ground-fault protection is a relatively new area, so considerable investigation and study are still in progress.

8.7.7 HIGH-VOLTAGE GROUND-FAULT COUPLING CAN PRODUCE V_0 IN HIGH-IMPEDANCE-GROUNDING SYSTEMS

Ground faults in the primary system produce a voltage in the generator secondary circuit through the primary-to-secondary capacitance of the unit transformer bank. The circuit is shown in [Figure 8.14](#). With sensitive voltage relays (59G) applied in high-resistance systems, this voltage can cause operation. Thus, 59G relays should have a time delay to permit the primary ground relays to clear high-side faults if the coupling voltage is greater than the 59G relay pickup.

This can be illustrated with the example of [Figure 8.10](#). Assume that the transformer capacitance between the primary and secondary windings (X_{CT}) is $0.012 \mu\text{F}/\text{phase}$. Using the values of $3R = 5019 \Omega$ from [Figure 7.11](#), the voltage across the grounding resistor is calculated as shown in [Figure 8.15](#). Calculation of the currents for a phase-*a*-to-ground fault on the primary 345 kV bus is shown in [Figure 8.15a](#). [Figure 8.15b](#) shows the calculation for a primary V_0 fault voltage of 81,467 V, which reflects through the interwinding capacitance to produce 1,293 V across the grounding distribution transformer primary. With a ratio of 18:240 kV, relay 59G receives 17.24 V. This is above the pickup, so the relay would receive operating energy until the 345 kV fault is cleared. These high-voltage faults are usually cleared at high speed, but 59G should be coordinated with the maximum backup time.

If resonant grounding is used for the generator, the primary ground fault may also affect the protection system. For the lower-voltage system, this coupled voltage probably will not be significant, as the V_0 for primary-side faults will be lower than on the EHV systems.

8.7.8 GROUND-FAULT PROTECTION FOR MULTIDIRECT-CONNECTED GENERATORS USING HIGH-RESISTANCE GROUNDING

Where multiple operators are connected to a common bus, as in [Figure 8.2](#), or in industrial systems where faults can result in an expensive interruption of processes, the high-resistance grounding by three distribution transformers, as discussed in [Section 7.5.2](#), may be used. Grounding exists independently of the generators in service. In the example of [Section 7.5.4](#), [Figure 7.13](#), 208 V

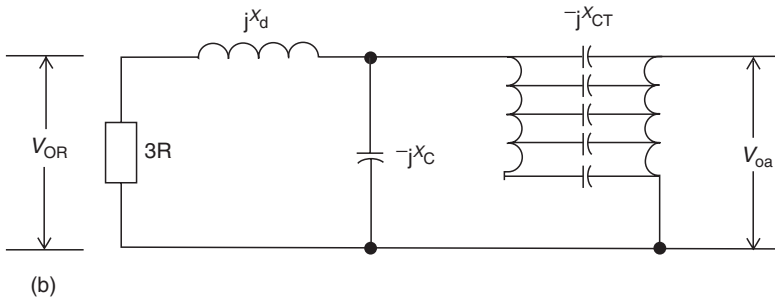
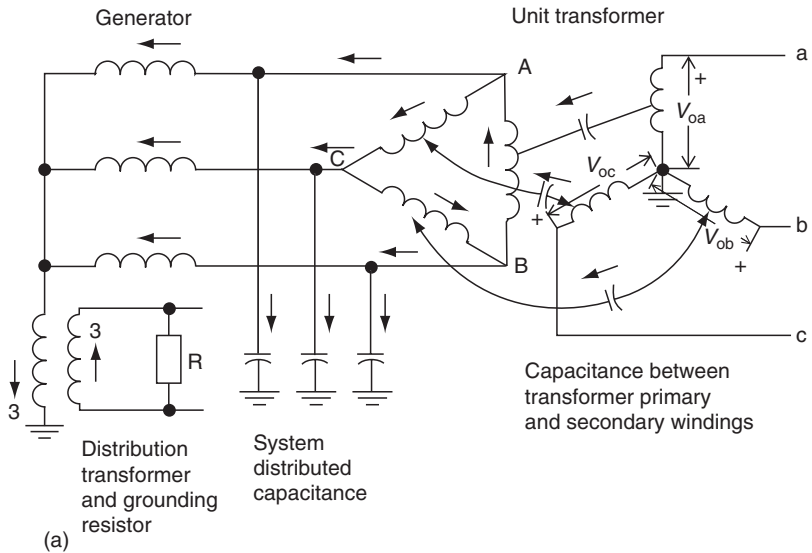
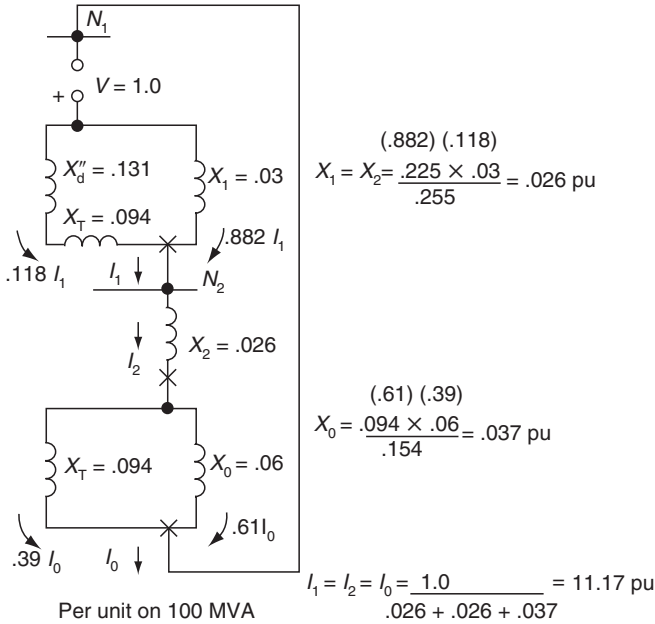

FIGURE 8.14 Capacitive coupling through transformer banks for primary-side ground faults: (a) three-phase system diagram; (b) equivalent circuit.

was available to operate relay 59G that was connected across the grounding resistor to provide good fault sensitivity. Because the system is otherwise ungrounded, sensitive $3I_0$ fault detectors in the various circuits connected to the bus can provide location of the fault.

8.8 MULTIPLE GENERATOR UNITS CONNECTED DIRECTLY TO A TRANSFORMER: GROUNDING AND PROTECTION

Most often, these are large tandem or cross-compound units operating from a common steam prime-mover source. The two units may be paralleled and connected to a common delta-unit transformer winding, or each generator



(a)

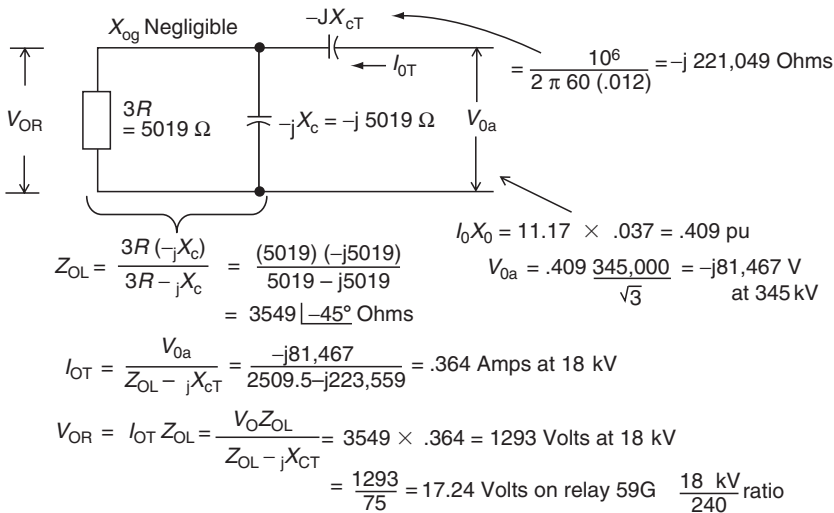

(b)

FIGURE 8.15 Example of a primary line-to-ground fault producing voltage across the high-impedance grounding system: (a) sequence networks and fault circulation; (b) grounding network and voltage calculation.

may be connected to separate delta windings on a three-winding-unit transformer. For the first or paralleled connection, only one of the generators is grounded, usually with high-impedance grounding. The other unit is left ungrounded. Ground faults in either unit will operate the ground protection as discussed earlier. The location of the fault will not be indicated, because the fault current level is practically the same for all fault locations. Both units must be shut down, as there is no breaker to isolate the two units.

With the generators connected to separate transformer windings, each unit must be grounded for ground protection. Separate generator protection should be applied to each generator unit. Without breakers between generators and transformer, the overall transformer differential protection must be of the multirestraint type and connected as discussed in [Section 9.8](#).

Each unit should have loss-of-field protection (40). Only one negative-sequence (46) and one distance (21) or three-phase (51V) relay for backup protection are necessary, and they can be connected to either unit. This is based on both units operating together all the time. If one unit can be operated with the other shut down, each unit should have complete protection, as outlined and summarized earlier in [Figure 8.5](#).

8.9 FIELD GROUND PROTECTION (64)

Ground detection for the exciter and field are important and usually supplied as part of that equipment, rather than applied by the user. However, if they are not supplied, or if additional protection is desired, protective relays are available.

For units with brushes, a relay (64) with a voltage-divider circuit can be connected across the field and the exciter with a sensitive DC-type relay that is connected between bridge network and ground. When a ground occurs in the field of exciter circuits, a voltage appears across the relay to produce operation. To avoid no-operation for a ground fault at a null point, one branch of the bridge includes a nonlinear resistor that changes this blind spot with voltage variations of the field.

Generators with brushless exciters are supplied with a way to drop pilot brushes on slip rings to measure the insulation level of the field on a periodic basis. The insulation of the exciter field is checked continuously. Both these normally provide an alarm for operator action, but can still be used to trip, if desired.

8.10 GENERATOR OFF-LINE PROTECTION

All the protection should be examined to see if it is possible to operate during the process of bringing the unit up to the rated speed and voltage to synchronize with the power system. For some units, such as steam turbines, this process can include operation at reduced frequencies for several hours. Thus,

the protection should be active from about one-fourth to one-half rated frequency and higher. When the relay's or instrument transformer's performance is impaired at these low frequencies, supplemental temporary protection should be provided.

8.11 REDUCED OR LOST EXCITATION PROTECTION (40)

8.11.1 LOSS OF EXCITATION PROTECTION WITH DISTANCE (21) RELAYS

Protection to avoid unstable operation, potential loss of synchronism, and possible damage is important and is applied for all synchronous machines. Such protection is included in the excitation system supplied with the machine, but additional protection is recommended to operate independently, as both supplemental and backup protection. Distance relays, as outlined in Chapter 6, are applied for this purpose.

Normally, the generator field is adjusted so that slightly lagging power is shipped into the system. Figure 8.16 provides an overview of synchronous

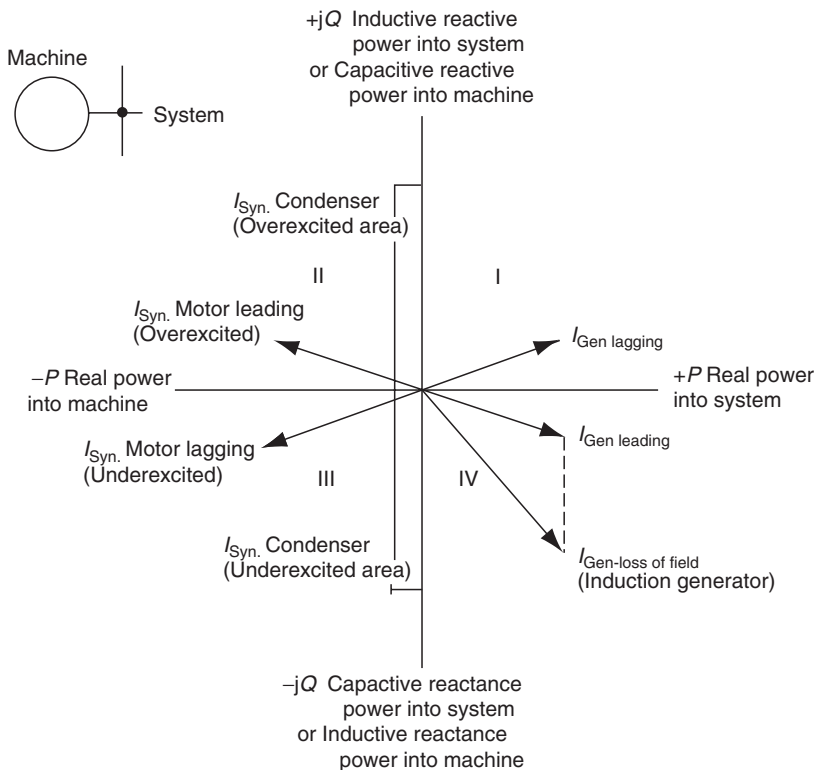

FIGURE 8.16 Power and related current diagram for synchronous machines.

machine operation. Lagging power shown in the first quadrant is the normal operating area. When the excitation (field) is reduced or lost, the current moves into the fourth quadrant. In this quadrant, the system must supply the missing reactive power. Synchronous generators have low or reduced stability in this area. If the system can supply sufficient inductive reactive power without a large voltage drop, the unit may run as an induction operator. Otherwise, synchronism is lost. This change is not instantaneous, but occurs over a period, depending on the unit and connected system. If the field was accidentally tripped, early alarm may permit the operator to restore it and to avoid a valuable and time-consuming shutdown and restart. If the field is not promptly restorable, the unit should be shut down.

Generators have characteristics known as capability curves. Typical curves are shown in [Figure 8.17a](#). Temperature limits are primarily zones, so these curves are the designer's thermal limit. As overheating varies with operation, three arcs of circles define the limits. In one area of operation, the limit is the overheating in the rotor windings; in another, in the stator windings; and in the third, in the stator iron.

As indicated earlier, generators should be operated cautiously in the leading or negative reactive zone. The added limit here is the steady-state stability limit (SSSL). This is defined as a circle arc where the offset (center) and radius are

$$\text{Center offset} = \frac{1}{2} V^2 \left(\frac{1}{X_d} - \frac{1}{X_s} \right) \text{ VA}, \quad (8.18)$$

$$\text{Radius} = \frac{1}{2} V^2 \left(\frac{1}{X_s} + \frac{1}{X_d} \right) \text{ VA}, \quad (8.19)$$

where V is the generator line-to-neutral terminal voltage, X the total equivalent impedance of the connected system, and X_d is the synchronous unsaturated reactance. These are power limits usually expressed in per unit, with X_s and X_d on the generator base.

This steady-state stability curve is typically as shown in [Figure 8.17a](#). It will vary with the generator and the system connected, as well as with the voltage. Although the system and voltage will vary during operation, these are usually relatively small for a given system.

The generator excitation system has a minimum excitation limiter (known as the underexcited reactive ampere limit) to prevent the exciter regulator from reducing the field below its set point. This is characteristically set just above the steady-state stability (see [Figure 8.17b](#)).

For application of a distance relay, these power curves must be converted to impedances for plotting on the R - X axes. This conversion of [Equation 2.17](#) and [Equation 6.7](#) is

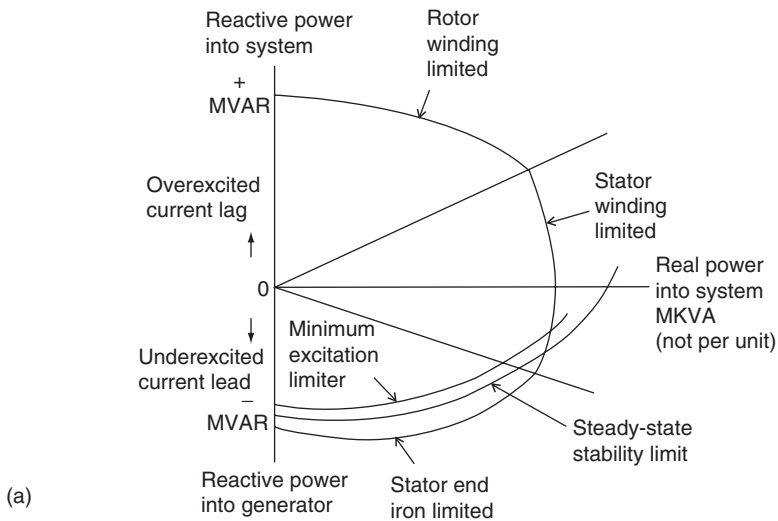

(a)

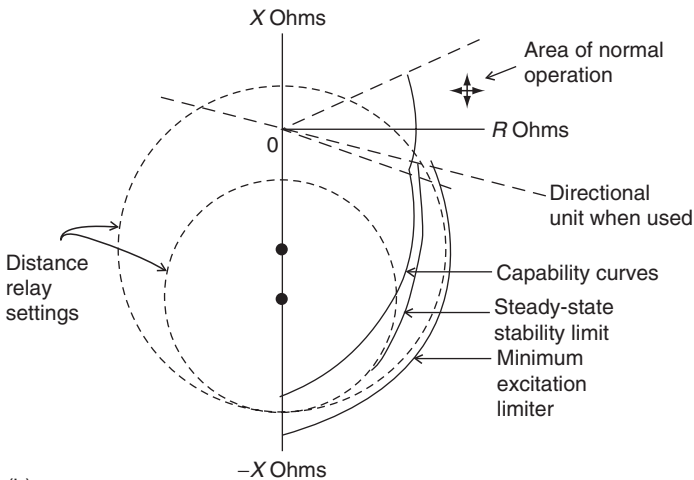

(b)

FIGURE 8.17 Typical power capability and stability curves for a generator and their conversion to an R - X diagram for (40) relay protection application; (a) capability and stability curves on power axes; (b) power curves transferred to R - X axes with distance-type relay protection.

$$Z_{\text{relay}} = \frac{kV^2 R_c}{\text{MVA } R_v} Z_{\text{pu secondary } \Omega}. \quad (8.20)$$

R_c and R_v are the current and voltage transformer ratios used for the distance relay, respectively. If the plot is made in primary ohms, the R_c/R_v factor

would not be used. From a value of MVA at the angle indicated from the capability curve, Equation 8.20 converts this to ohms. This converted value is plotted on the R - X diagram at that angle. This conversion is shown in Figure 8.17b for both the underexcited capability curves and the stability curve. For the stability curve, the conversion can be made easier if the value of X_s and X_d are known. Then, the stability circle center (offset) from the origin is $1/2(X_d - X_s)$ and the radius is $1/2(X_d + X_s)$. If the plot is in secondary ohms, X_d and X_s must be in secondary ohms as per Equation 8.20.

In the R - X diagram of Figure 8.17b, the origin is at the generator terminals, with X_d plotted below the origin and X_s plotted above; also, that particular increasing or higher power is indicated by a longer distance from the origin in Figure 8.17a, but by the shorter impedance vector in Figure 8.17b. Thus, in the power diagram (Figure 8.17a), safe-operating power is within the capability and stability curves, but outside the curves in Figure 8.17b. The minimum excitation limiter operates on a power level lesser than the stability limit.

The normal-operating area is as shown in Figure 8.17b. With reduced excitation or loss of excitation, the impedance phasor moves slowly as the flux decreases into the fourth quadrant. A distance relay (40) enclosing this area provides a good means of detecting this condition. Several setting modes are available.

1. For complete loss of field, the distance relay is set as illustrated by the smaller circle in Figure 8.17b. The diameter is the order of X_d , with the upper part of the circle 50%–75% of X'_d below the origin. X'_d is the transient reactance of the generator. The relay operates when the impedance vector moves into this circle. Operating times of about 0.2–0.3 sec are used with a complete shutdown of the generator.
2. To detect low excitation, partial loss, or complete loss, the diameter is set preferably inside the minimum excitation limiter setting, but outside the generator capability and stability limit curves. This is shown by the larger-diameter dotted circle. It is not always easy to make this setting as suggested; good judgment and compromise may be necessary. A directional unit is required to avoid operation of nearby faults and stable transient swings. Relay (40) operation is below the dashed directional line and within the larger dashed operating circle. Wherever applicable, an undervoltage unit set to drop out between 87% and 80% of normal voltage is used to supervise the relay operation. If the power system can supply reactive power to the generator without a significant drop in voltage, an alarm is set off for possible corrective action, followed by a shutdown trip after a particular time delay. Typical delays used vary with machine and system, but are 10 sec to 1 min.

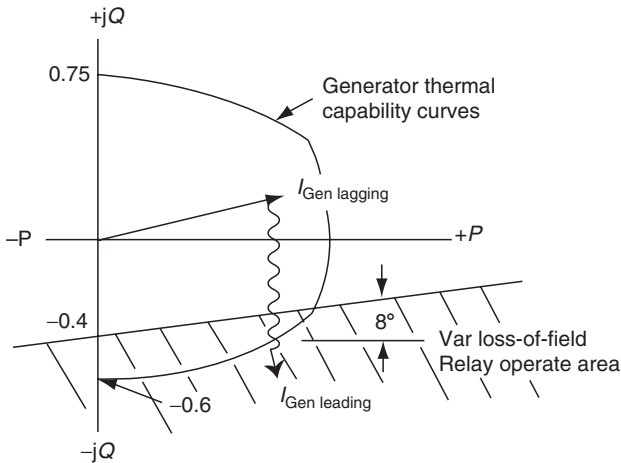

FIGURE 8.18 Loss of excitation protection with a var-type relay.

If the voltage drops below the voltage unit setting, tripping is initiated with operating times about 0.2–0.3 sec.

3. For large, important generator units, a combination of (1) and (2) is used by applying two (40) loss-of-field relays.

8.11.2 LOSS OF EXCITATION PROTECTION WITH A VAR-TYPE RELAY

A directional power relay connected to operate on inductive vars from the connected system can be applied to detect loss of excitation. An application is shown in Figure 8.18, where the relay has an 8° characteristic.

Normal synchronous generator operation is kilowatt (kW; MW) power with inductive vars flowing into the connected system. When the generator field is reduced or lost, the system will attempt to supply inductive vars to continue operation as an induction generator. Thus, the generator current will move into the leading area (vars from system) to operate the var relay as shown. A 0.2 sec time delay is recommended to prevent operation on transient conditions.

8.12 GENERATOR PROTECTION FOR SYSTEM DISTURBANCES AND OPERATIONAL HAZARDS

In the previous sections the discussion has covered primary protection for faults in the generators and backup protection for uncleared or delayed faults using relays 21, 46, and 51V. Loss of excitation (40) may be caused by a rotor field fault or by inadvertent tripping of the field. In this section problems and protection for other hazards that may be encountered as a result of system disturbances or operator errors are discussed.

8.12.1 LOSS OF PRIME-MOVER: GENERATOR MOTORING (32)

If the prime-mover supply is removed while the generator is connected to the power system and the field excited, the power system will drive the unit as a synchronous motor. This is particularly critical for steam and hydrounits. For steam turbines it causes overheating and potential damage to the turbine and turbine blades. Low water flow for the hydrounits can cause cavitation of the blades of the turbine. This can also occur by closing the steam or water flow valves very rapidly during a load-reduction phase or by tripping the turbine, while not correspondingly tripping the generator breaker.

Typical values of reverse power that are required to spin a generator at synchronous speed with no power input in percentage of the nameplate kilowatts are

- Steam turbines, condensing types 1%–3%
- Steam turbines, noncondensing types 3+%
- Hydro turbines 0.2%–2+%
- Diesel engines $\pm 25\%$
- Gas turbine 50+%

Various detection means are provided as part of the generator and its control, but a supplementary reverse power relay (32) is recommended and is shown in [Figure 8.3](#) and [Figure 8.5](#). The power directional relay is connected to operate when real power flows into the generator. Typical relay sensitivities with microprocessor relays are as low as 1 mA, which may be required when a generator can operate with partial prime-mover input. The operating time can be approximately 2 sec.

8.12.2 OVEREXCITATION: VOLTS PER HERTZ PROTECTION (24)

Generators as well as transformers must not be subject to overvoltage except for short or transient excursions. With normal operation near the knee of the iron saturation curve, small overvoltages result in significant exciting currents in transformers, and excessive flux densities and abnormal flux patterns in generators. These can cause severe and extensive damage.

The field excitation current, at rated output, is greater than that required at no-load, so it is important to reduce the excitation correspondingly as load is reduced. Normally, this is accomplished by the regulating system, but incorrect voltage signals, loss of VT fuses, or other failures in these systems, can result in high overvoltage.

A particularly dangerous period is during the time when the generator is disconnected from the system and the speed is changed. The generator voltage is proportional to frequency and the magnetic flux, so overvoltage protection should have a constant pickup as a function of the ratio of voltage to frequency, a volts/hertz (24) type. Protection supplementary to that in

the generator controls is suggested by using two-level volts/hertz units. One setting should be about 110% rated voltage to the alarm with a subsequent trip within approximately 1 min, the other set at near 120% rated voltage to trip on the order of 6 sec. A separate VT supply is preferable. The 24 unit is shown in Figure 8.3 and Figure 8.5.

Overvoltage (or undervoltage) can also occur when a generator that is connected to a distribution system is islanded with other loads. This is discussed further in Section 8.13.

8.12.3 INADVERTENT ENERGIZATION: NONSYNCHRONIZED CONNECTION (67)

In recent years, several cases of severe damage of generators have resulted from the unit inadvertently connected improperly to the power system. This can occur by incorrect closing of the circuit breaker while the unit is on turning gear, coasting to a stop, at standstill, or by improper synchronization. The normal protection may operate in many cases, but not necessarily for all possibilities. This is an increased danger if some of the protection is not available or useful at low frequencies of start-up or shut down. Because the unit or generator breaker(s) may be the problem, it is important that the adjacent breakers be opened promptly by local breaker failure or by remote tripping. Additional protection for this is provided by three-directional, inverse-time-overcurrent units (67), one in each phase, connected to operate for reverse power into the generator. On the basis of current normally flowing out of the generator into the power system, the relay characteristics and connections should provide an operating zone from about 30°–60° through 180° (reverse power into the generator) to 210°–240° lead. Typical pickup should be about 0.5 pu current with 2.0 pu current-operating times of near 0.25 sec. This application replaces motoring protection (32) and is more responsive to the conditions just outlined. The 67 units are shown in Figure 8.5.

8.12.4 BREAKER POLE FLASHOVER (61)

Where there is the potential for a pole flashover before synchronizing or after separation from the power system, additional pole disagreement protection is recommended. This condition is likely to occur with no-fault and light-load, so the current can be very low. In one case, a flashover of a 500 kV breaker pole of a 150 mi line, which was open at the remote end, resulted in sufficient charging current to maintain 70% rated voltage at rated speed on the generator. I_2 was 12% above the generator's rated current. This can be cleared only by prompt reduction of the excitation. Local backup and remote tripping of the far end of the line remove the system, but not the generator. Negative-sequence protection may respond, but with long response time, or it may not respond at all.

Sensitive protection (61) breaker pole failure (see Figure 8.5) compares the magnitude levels in the three phases. It operates if one phase current is below a set value, while either of the other two is above its set value. Typical sensitivities provide operation if one phase current is less than 20–60 mA and the other above 40–200 mA. These are in the primary or high-voltage side of the unit transformer. A 3:1 level difference with operating times of about 1/2 sec is suggested.

Where two high-side generator breakers are used, as in a ring or breaker and half buses, there can be enough normal unbalance circulating in the bus to operate this sensitive protection. For these applications, the unbalance operation should be supervised by a zero-sequence voltage level detector, or a higher setting used.

8.12.5 THERMAL OVERLOAD (49)

The generator control system usually provides protection from overloads. Where the generator has resistance temperature detectors (RTDs) within the windings, additional protection can be provided by a bridge network relay. High temperature in the unit unbalances the network and the relay operates.

If RTDs are not available, a replica-type relay may be applied. Stator current through the relay produces replica temperatures to operate when they are in excess.

8.12.6 OFF-FREQUENCY OPERATION

Steam turbine blades are designed and tuned for efficient operation at a rated frequency rotation. Operation with load at different frequencies can result in blade resonance and fatigue damage in the long blades (18–14 in.) in the turbine low-pressure unit. Typical limits for 50 Hz machines with 18–25 in. low-pressure unit blades are about 58.8–61.5 Hz for continuous operation, but, between 56 and 58.5 Hz, only 10 min of operation is permitted, that is accumulated over the entire lifetime of the machine. For turbines with 25–44 in. blades, the typical continuous range is between 59.5 and 60.5 Hz, 60 min accumulated lifetime between 58.5 and 59.5, and 10 min accumulated lifetime between 56 and 58.5 Hz. For these units underfrequency relays are suggested. One application uses a three-step unit, one set without time delay at 56 Hz, another at 58.4 Hz with a 2 min delay, and the third at 59.4 Hz with a 6 min delay. IEEE C37.106 (see Bibliography) addresses abnormal frequency operation and provides details on frequency operating limits as specified by various generator manufacturers. Hydrounits are not subject to damage because of underfrequency as other types of generating systems.

Under normal operation, frequency is held within very tight limits by generator controls. Off-frequency operation can occur upon failure of the generator controls. Under- and overfrequency relaying is applied to provide backup for these controls. A common cause of off-frequency operation is

widespread system disturbances during which multiple line trippouts occur and islands are formed within the power system network. Within such islands, a significant mismatch between load and generation is expected to occur. When load in the island exceeds available generation, frequency will decay at a rate that is related to the amount of mismatch. Load shedding schemes are usually applied on power systems as a means to attempt to balance the load and generation within such islands. During such events, it is possible for the frequency to stabilize at low values that fall within areas that can be damaging as described earlier. It is very important that the settings on underfrequency relaying be coordinated with load shedding schemes. Underfrequency relays should be constantly coordinated for the load shedding schemes to function such that the island can be stabilized. If generation is tripped before complete operation of the load shedding systems, collapse of the island is possible. The recommended settings will characteristically coordinate with most load shedding schemes but this should be analyzed on a case-by-case basis. Overfrequency is usually the result of a sudden loss of load. Overfrequency can also occur due to failure of generator controls or as a result of islanding. Overfrequency operation due to excess power in an island will not cause overheating unless rated power and about 105% voltage are exceeded. Application of overfrequency relaying for turbine blade protection is not critical as generator controls can be usually relied on to run back generator output to achieve the required reduction in frequency. Overfrequency relaying is sometimes applied as a means to backup generator controls, to prevent damage caused by overspeed (as a supplement to mechanical overspeed devices), or as a means to try to balance load and generation in an island when excessive generation exists. Hydrounits are especially inclined to overspeed due to the relatively extended time required to close water inlet gates. Speeds up to 150% of normal are possible on loss of load. Governor action should bring speed back to normal within a few seconds; however, should these controls fail, speeds up to 200% are possible. Overfrequency relaying can be applied to hydrounits to protect against such possible runaway speeds. The settings should be such that they do not interfere with normal governor action. The required settings need to be analyzed on a unit-specific basis.

Applications of over- and underfrequency relaying for distributed generation inertia protection is discussed later in this chapter.

8.12.7 OVERVOLTAGE

A major cause of overvoltage is the sudden loss of load. Power equipment involving iron (rotating generators, transformers, and such) operate close to the knee of their saturation curves. Thus, small overvoltages result in large increases in exciting current and cause major damage. Typical permissible overvoltage at no-load are

Instantaneous overvoltage settings should be about 106%–110% of rated voltage to ensure prompt removal.

Generators	Transformer
105% continuous	110% continuous
110% 30 min	115% 30 min
115% 5 min	120% 5 min
125% 2 min	130% 3 min

8.12.8 LOSS OF SYNCHRONISM: OUT-OF-STEP

For many generators, being out-of-step is a system problem with the electrical center out in the transmission area. Once the voltages of the separate generation sources swing 180° apart, recovery is not possible, and therefore, separation must be made. Out-of-step detection and tripping is covered in [Chapter 14](#). No relaying is normally applied at the generator in these cases.

With larger generators and higher-voltage transmission, the system electrical center can move into the unit transformer and also into the generator. For these systems, out-of-step protection at the generator must be added, for none of the other protection can respond adequately. The large circle setting of the loss-of-field unit (40) will operate for swings passing near and at the bus, and within the unit transformer and generator, but can pass out before the (40) relay times out. A sustained out-of-step condition can result in high currents that cause forces in the generator windings and undesired transient shaft torques. It is possible for these torques to be of sufficient magnitude so that they cause the shaft to snap. Pole slipping can also cause excessive overheating and shorting at the ends of the stator core. In addition, out-of-step operation can cause damaging transient forces in the windings of the unit transformer. On account of these reasons, it is essential that whenever it is possible for an out-of-step swing trajectory to travel through the impedance of the unit transformer or the generator itself, that dedicated relaying to detect such a condition, and initiate an immediate trip of the generator be applied. It is difficult to predict the possibility of such a condition with a high level of confidence. Due to this reason, it is recommended that out-of-step relaying be applied to all larger generators. System stability studies should be used as an aid in predicting impedance trajectory that would be expected during an out-of-step event. Data from such studies can also serve as a guide for setting the respective out-of-step relaying. Additional specifics regarding this separate protection are discussed in [Chapter 14](#).

8.12.9 SUBSYNCHRONOUS OSCILLATIONS

The application of series compensation in long EHV transmission lines provides increased power transmission and stability but may result in

subsynchronous oscillations. This may also occur for a generator connected to a HVDC transmission line.

The natural frequency of a system (f_n) with X_c capacitive reactance and X_l inductive reactance

$$f_n = f_s \frac{X_c}{X_l}, \quad (8.21)$$

where f_s is the synchronous or normal system frequency. As X_c is less than X_l , f_n is subsynchronous. This results in problems in the system, particularly in the generators. The rotor rotating at synchronous frequency turns faster than the magnetic field produced by the subharmonic frequency. This results in a negative-slip and negative-resistance effect, with the generator tending to operate as an induction generator. When f_n is close to f_s , the slip is small, and the negative resistance is large. If this resistance is greater than the system resistance, the circuit becomes self-excited, and the subsynchronous current magnitudes grow. This can cause overheating in the system. One solution is to use low-resistance pole-face damper windings to reduce the rotor resistance.

Another effect of the subfrequency is to produce oscillating torques in the generator, with additional transient torques occasioned by switching and faults in the system network. There is a danger that these torques may produce rotor damage.

Various measures can be taken to mitigate this, and protective relays have been developed to detect subsynchronous resonance. One type measures torsional motion, and another senses the level of subsynchronous currents in the armature. This is a complex phenomenon and beyond the scope of this book, particularly as it occurs only in a few systems with series capacitance.

8.13 LOSS OF VOLTAGE TRANSFORMER SIGNAL

Signals from VTs connected to the output terminals of generators are used to supply associated protective relays and voltage regulating equipment. Two VTs are often used, one supplying the relaying and the other supplying the regulator. Loss or distortion of these voltage signals can cause problems as follows:

1. Incorrect operation of the related relaying resulting in an unnecessary tripping of the generator
2. Failure of the related protective relaying to operate when required resulting in possible extensive damage to the generator or associated facilities
3. Improper operation of the voltage regulator, which can result in over excitation and related damage

Loss or degradation of the voltage signal can be caused by the opening of a primary or secondary VT fuse, control wiring problems, or poor contact at a VT stab.

Protection against the undesired results of a loss of a VT signal should be provided by applying a voltage balance relay (60). The voltage balance relay is supplied with three-phase voltage from each of the VTs that are connected to the generator terminals and compares the “balance” between the three-phase voltages supplied from each of the voltage transformers. The relay will operate when the unbalance exceeds a value determined by the setting applied to the relay. Operation of the voltage balance relay should set off an alarm to alert personnel of the problem. Other recommended actions that an operation of the voltage balance relay should initiate are as follows:

1. If the problem lies in the signal supplying the voltage regulator, trip the regulator from automatic to manual. This action will prevent the regulator from increasing the excitation to dangerous levels.
2. If the signal from the relaying VT is in trouble, action should be taken to block operation of the related relaying. This can include loss-of-field, reverse power, backup distance, and voltage restraint overcurrent relays. Such action should not be taken if it is possible that the alarm might not be promptly detected.

The voltage-balance relay should be set as sensitive as possible while minimizing the risk of operation for normal errors and voltage fluctuations. A setting of around 15% unbalance will usually satisfy this requirement. Providing a setting with maximum possible sensitivity promotes desired performance when the voltage unbalance is problematic but not severe. Such smaller unbalances can occur as a result of such conditions as poor contacts in the wiring of the voltage circuitry or feedback voltage from wye (grounded)-delta auxiliary transformers that are connected in the VT secondary circuits. Such feedback can act to support voltage on a phase of the voltage circuitry beyond a blown fuse and therefore significantly reduce the degree of unbalance expected from the blown fuse condition.

8.14 GENERATOR BREAKER FAILURE

Protection should be provided for larger generators such that the generator is isolated in the event when its breakers fail to open subsequent to receiving a signal to trip. Due to the nature of generator faults and problems, it is not possible to rely on remote relaying to operate in order to provide such isolation. Therefore, a local breaker failure scheme is required for the generator breaker(s).

Local breaker failure is discussed with regard to transmission line breakers in [Chapter 12](#). The design of local breaker failure schemes for generator breakers is similar to that for line breakers with some additional considerations required. Line breaker failure schemes are typically supervised by overcurrent fault detectors to enhance security of the scheme. In the case

of generator faults and problems, sufficient current may not exist to assure that such fault detectors may operate. Trips initiated by ground fault relaying, overexcitation, and underfrequency fall into this category. Consequently, the design of breaker failure schemes for generator breakers needs to include breaker auxiliary “a” contacts in parallel with the fault detector contacts. If sufficient current does not exist to operate the fault detectors, the “a” contacts will provide the required indication for the scheme so that the breaker remains in the closed position. If the generator breaker is an independent pole breaker, “a” contacts from each phase may need to be connected in parallel.

Considerations for the settings for the local breaker failure timer and fault detectors are similar to those for line breakers. The dropout time for the fault detectors should be immune to the effects of DC offset and current transformer saturation as these effects are highly possible for faults near large generators.

8.15 EXCITATION SYSTEM PROTECTION AND LIMITERS

Exciters provide the energy to supply generator field excitation. Earlier designs used rotating exciters that provided a DC output for supply to the generator field. Modern units usually utilize static exciters to provide this function. Many older units are retrofitted with static excitation systems when their existing rotating exciters require replacement. The strength of generator field excitation controls the var output of the machine. A weak field results in output vars to be leading, whereas a strong field results in lagging var output. When operating with the voltage regulator in the automatic mode, the strength of the field is automatically and constantly changed, based on a feedback signal that reflects a system voltage level. With the voltage regulator in manual mode, the excitation level is controlled by a manual set point. Voltage regulators for smaller generators are very diverse and are capable of providing a constant output power factor, voltage level, or var output level.

Generator fields are designed with short-term overload capability. This is important so that the field can be overexcited (forced) for short periods of time to provide high levels of var output to support the power system during disturbances that cause voltage to decay. Field forcing can help the power system to ride through such disturbances. Standards require that generator fields be capable of withstanding 125% of normal field voltage for at least 1 min.

8.15.1 FIELD GROUNDS

The field of an AC synchronous generator operates as an ungrounded DC system. A single ground on the field does not cause any problem. A second ground, however, causes a portion of the field winding to be shorted, which can result in unbalanced temperatures and damaging vibration.

Protective systems are applied to detect field grounds and deteriorating field insulation. Field ground detection systems are often supplied by the

generator manufacturer. Various types of schemes are employed to provide this function. One such scheme connects a separate DC source to the field through a voltage relay. The voltage relay detects any field leakage current to ground. Another scheme employs a voltage divider and a sensitive over-voltage relay between ground and divider midpoint.

As the first ground on the field does not cause a problem, many generator owners elect to alarm, rather than trip, upon operation of the field ground detection system. Upon receipt of the alarm, the generator owner can take the unit out of service at the first convenient opportunity. There is some risk associated with this practice, since, as indicated, damage may occur if a second ground develops before taking the generator out of service. The decision to trip or alarm on operation of the field ground sensing scheme depends on operating considerations and risk tolerance of the owner of the generator. If tripping of the unit can degrade system reliability and operators are available to promptly recognize and respond to alarms, alarm setting may be the best option. For smaller units that are less critical to system reliability and where responses to alarms may be delayed, tripping by field ground protection may be better.

8.15.2 FIELD OVEREXCITATION

Overexcitation for the field is provided by the application of a field overexcitation limiter and field overexcitation protection. It should be understood that field overexcitation protection is different from overexcitation protection provided on the generator. Generator overexcitation schemes protect the generator and unit transformer when the volts–hertz ratio is excessively high when generator output voltage is high or during startup, when frequency is below normal. Overexcitation of the field may occur when low system voltages cause the voltage regulator to boost the output level of exciter voltage to high values.

The field maximum excitation limiter and overexcitation protection are basically built into the exciter by the manufacturer. These systems may be designed with inverse or fixed time characteristics. Settings for these devices should protect the field from damage while allowing for full use of desired field capability. Overexcitation protection should be set to operate before field damage can occur. It should be coordinated with the specific overload characteristic of the field or, if this characteristic is not available, with requirements as specified in related generator standards. The overexcitation limiter setting should be set to coordinate with the overexcitation protection setting such that the limiter action will always occur before the tripping action of the protection unit is initiated. When limiter action is initiated, further boosting of the output exciter voltage by the voltage regulator is prevented. The limiter setting should provide leverage for desired field forcing. Field overload protection is also provided by an overcurrent relay that monitors field current.

8.15.3 FIELD UNDEREXCITATION

During periods of high system voltages, the action of voltage regulators may reduce field voltage to an extent that may cause the generator loss-of-field relay to operate or the generator to lose synchronism with the system. A minimum excitation limiter is applied to prevent such occurrences. Limiter action prevents any further reduction of the exciter output voltage by action of the voltage regulator. The minimum excitation limiter should be set such that limiting action occurs before operation of the associated loss-of-field relaying. Correspondingly, loss-of-field relaying is set to operate before the loss of steady-state stability. The minimum excitation limiter, however, should allow for maximum leading power factor generator operation to provide support for the power system during operating conditions when high system voltages need to be constrained.

8.15.4 PRACTICAL CONSIDERATIONS

Applications and settings for protection and controls associated with generator excitation systems play an important role in obtaining optimal operation of the generator and the associated power system to which it is connected. In the past, the utility protection engineer was often called upon to provide input into this area, because the utility desired to optimize the var and voltage support, those generators were capable of providing to enhance the operation of the power system. Issues also exist that require coordination between generator protection, and certain protective and limiter devices utilized on the excitation system. The deregulation and separation of ownership of generation from the delivery portion of the industry promote a less coordinated effort in this area. As separate entities, generator owners are inclined to place a high emphasis on self-interests with a focus on the safety of the generator itself and its profitability. Support for the power system can become secondary in this environment. For this reason, it is important that entities responsible for the reliability and proper operation of power systems and related markets address these issues in associated documents related to standards, inertia requirements, and market structures. It is important that requirements exist such that larger generators be normally operated with its voltage regulator in the automatic mode. This requirement helps assure prompt var and voltage support for the power system during system disturbances. Such support can act to prevent collapse of the power system due to angular or voltage instability. Assurance that settings that are applied to exciter controls are properly coordinated with other protection and control devices is also an important requirement to promote safe and reliable operation of power systems.

8.16 SYNCHRONOUS CONDENSER PROTECTION

Synchronous condensers usually operate as unloaded motors to supply capacitive reactance to the system. Protection for these units is as shown in [Figure 8.3](#), with the addition shown in [Figure 8.5](#), as indicated by the system

and operation requirements. The loss-of-field protection (40) should be set with its operating circle to enclose an impedance seen at the terminals with zero-excitation, or

$$Z = \frac{1}{I_{\text{short circuit}}} \text{ pu.} \quad (8.22)$$

Operation to supply capacity will operate the distance unit, but tripping is supervised by the voltage unit. No protection exists for inductive reactance into the system (overexcited), because the directional-sensing unit is open and the distance unit may or may not be operated.

8.17 GENERATOR-TRIPPING SYSTEMS

In general, immediate tripping is recommended for all faults in the generator and associated areas. This means opening the main and field breakers and closing the turbine stop valves or gates. Such action results in sudden and complete shedding of load that, particularly at full load, can be a severe shock to the mechanical systems. For phase and ground faults, except possibly with high-impedance or resonant-grounding systems, immediate tripping is mandatory. With very limited ground fault current, supervised or delayed tripping is sometimes used. The problem is often that any fault indicates damage and may develop to other phases, or a second fault may occur, all with the potential of a high increase in damage and danger. Even with immediate tripping, the stored energy in the rotating mass continues the fault and damage for a considerable period.

The alternatives preferred for complete immediate trips are (1) permissive shutdown where the main field breakers are tripped after the turbine stop valves or gates are closed, (2) alarm with fixed time-delay trip to permit operator action, and (3) alarm only. However, these are applicable only for ground faults when using high-impedance grounding, and as an individual system preference.

8.18 STATION AUXILIARY SERVICE SYSTEM

Power sources require auxiliary power for their operation, especially synchronous generators. This is supplied by a station service transformer as shown in [Figure 8.2](#), [Figure 8.4](#), and [Figure 8.5](#) to operate various pumps, fans, and such appliances required in the operation of the generator. The secondary power supply system is equivalent to a critical continuous process industrial plant. Protection of the transformers, motors, and feeders is discussed in later chapters.

An alternative power supply is provided. Continuous paralleling of the two sources is not recommended. Thus, a transfer from one source to another

should be preferably fast when an emergency occurs, to avoid decay of frequency and voltage during the dead period of transfer. An “open” transfer disconnects one source before the second is connected. In a “closed” transfer both sources are in service for a brief interval. An example of an open transfer is energizing the trip coil of one and the close coil of the other, jointly. Because breaker closing is slightly longer than breaker tripping, a short period exists when both are open.

Closed transfer is required where the auxiliary motors do not have sufficient inertia to ride through a brief open period. If a fast transfer is not used and motors are involved, the emergency source should not be applied until the voltage on the motors has declined to about 25% of rated. A synchronism check (25) relay may be required and is recommended to assure that the two sources are in synchronism.

8.19 DISTRIBUTED GENERATOR INERTIE PROTECTION

BPGs are characteristically interconnected to the power system through switchyards or are tapped into lines that are protected with pilot relaying. Bulk power lines are utilized for transmitting power, and customers normally do not tap directly into bulk power lines for a source of power. Most BPGs are large in size and employ differential relaying to protect its facilities. The zones of protection of these differential relays normally overlap the intertie breaker(s). Breakers at the intertie switchyard or the generator intertie breaker that taps a bulk power line become terminals of bulk power lines and are equipped with appropriate pilot and backup relaying as utilized at remote terminals. Faults within the generator facility are covered by, and will be cleared with high speed, through differential relaying. When the customers are not tapped directly to bulk power lines, there is a low probability that a BPG, on its own, will become isolated with other utility load. For these reasons, special relaying at the intertie location of BPGs is not required. These generalities may not hold true in some special cases for which case-specific protection analysis is required.

Different conditions exist in the case of distributed generation. Such generation can be highly variable in size with different types of connections at locations that are scattered throughout the subtransmission and distribution systems. Such generators are often tapped into the power system with a single breaker that may be located on the high or low side of a connecting transformer. Distribution lines and many subtransmission lines are not protected by pilot relaying but utilize independently operating protective systems that are made up of relaying, such as overcurrent and distance elements. As the lines to which the DGs are connected will also supply load to many other utility customers, there is a good chance for the DG to become isolated, on its own, with other utility loads. DGs can be small in size, and, as such,

sophisticated protection for the generation facilities is not justified or applied. These conditions dictate that special protection be applied at the inertia location. Such inertia relaying is required to protect the utility power system to which the generator is connected. By nature, however, such relaying will also provide a degree of protection for the DG.

Objectives of distributed generation inertia protection are as follows:

1. Assure that the quality of power supplied to other utility customers remains within standards when the DG is connected and operating normally in parallel with the utility system, when the DG is connected or disconnected from the power system, or when it becomes isolated as an island with a portion of the utility load.
2. To assure that faults on the power system are isolated in a timely manner when conditions dictate that the DG is disconnected from the system for the fault to be de-energized.
3. Promote power system reliability by assuring that faults on facilities owned by the distributed generator are cleared by the inertia or other breaker at the generation facility rather than by other interrupting devices located on the utility system.

Requirements for DG inertia protection are provided in IEEE Standard 1547, "Interconnecting Distributed Resources with Electric Power Systems." It should be recognized that overall industry standards, such as this, need to cover a wide range of varying types of power systems. As such, such standards tend to be more general, rather than detailed, in nature, prevent over restriction in specific applications. For this reason, it is critical that utility protection engineers provide input to assure that the specific standards and requirements for interconnecting distributed generation to their system, adequately recognize and address all specific and pertinent hazards. It would be prudent for such standards, which may be developed by, or by a combination of, entities such as the utility, the associated independent system operator, or the state in which the utility operates, to utilize industry standards such as IEEE Standard 1547 as a base, with allowances for variances or additions, as required to meet specific utility needs.

8.19.1 POWER QUALITY PROTECTION

Utilities are obligated to deliver power with voltage and frequency levels maintained within limits as established by regulatory bodies. Operations outside of these limits can cause damage to customer equipment. Voltage flicker, voltage dips, and power outage time are also measures of the quality of power supplied. Excessive flicker, voltage dips, and outage time can have negative effects on the operation of electrical and electronic equipment and can result in customer complaints, lawsuits, and punishment from regulators.

With respect to distributed generation, an operating condition that causes power quality concerns is when the DG operates in isolation with a portion of the utility system and continues to supply power to other utility customers, which are connected to the isolated system. Such operation is referred to as “islanding.” There are various conditions that can cause islanding to occur. When a DG is connected to a radial line, a bus fault at the station from which the line originates will cause the line breaker to open without requiring fault relays at the generator to operate. Inadvertent opening of the line breaker, faults on the connected line that are cleared immediately on the opening of the line’s source breaker, and fuse saving protection practices are some other causes for islanding. When islanding occurs, a mismatch will undoubtedly exist between the output of the DG and the load that exists within the island. If the amount of island load is considerably higher than the generator, continued operation of the island will not be sustainable. If the island load is lesser than, or in the proximity of, the generator rating, the generator may continue to supply power to the isolated load. It is probable that such supply will be at voltages or frequencies that are outside established limits. Reconnecting the island to the power system is not possible without synchronizing facilities at the power system interrupting device that was opened to create the island. It is desirable, therefore, to provide protection to automatically disconnect the isolated generator from the power system when an island is formed. The load in the island that is lost can then be reestablished by the utility from its normal or alternate sources as per the availability of the sources. The DG must be isolated from the island even if sustained operation of the island was not possible due to the load in the island exceeding the generator rating so that the load can be restored from the utility system.

Anti-islanding protection should be provided by overvoltage (59), undervoltage (27), overfrequency (81O), and underfrequency (81U) relaying. Operation of these relays should initiate the isolation of the DG from the power system. Settings for these relays should be such that the under-/overvoltage and frequency bandwidth is as narrow as possible while providing reasonable assurance that operation will not occur on normal voltage and frequency variations, or for transient variations that may occur during system disturbances or motor starting. Narrow bandwidth settings will promote a high assurance that the DG is tripped when an island is created unless a close match exists between the island load and the generator capability, with the available controls that are capable of maintaining voltage and frequency within narrow limits. Settings in the area of 95% and 105% of nominal voltage would be reasonable for the under- and overvoltage relays, respectively. Settings of about 59.5 Hz for the underfrequency relay and 60.5 Hz for the overfrequency relay would be appropriate. A time delay is required on the undervoltage relay to also faults on the power system for which it is not necessary for the DG to trip, to clear. A time delay between 0.5 and 1.0 in.

should be adequate. Limited time delays of 0.1–0.2 in. for the overvoltage, underfrequency, and overfrequency relays are to override transients. An additional low-set voltage relay may be applied with a lower time delay to facilitate the speed at which load can be restored when the island voltage collapses suddenly due to island overload. Care must be taken when applying such an undervoltage relay, however, to assure that its setting will not allow operation on power system faults for which tripping of the generator is not required.

In some cases, a power directional relay can be applied to provide anti-islanding protection. Such application is practical when the amount of load that the DG is allowed to export to the power system is lesser than its rating. A setting of about 10% above the maximum permitted export power can be applied. A time delay should be applied to override the time required to clear faults on the power system for which generator tripping is not desired as power flows in excess of the setting can exist during such fault conditions. In cases where the DG is not allowed to export any power to the utility, a sensitive power directional relay can be applied on the generator side of the interconnecting transformer and set to operate on the power losses of the transformer. This will require a very sensitive setting. However, power relays are available that can be set with such sensitivity. Power directional relaying cannot be relied on to operate when voltage in the island collapses suddenly on account of overload.

In the case of larger generators for which the impact of islanding could affect a large number of customers, the application of transfer trip operating over a suitable communication medium is recommended. The transfer trip signal is initiated whenever breakers on the power system that indicate the generator are isolated with a portion of the system kept open. For example, the transfer trip signal would be initiated upon opening of a line breaker on a radial line to which a DG is connected. Receipt of the transfer trip signal at the generation location initiates tripping action so that it can isolate the generator from the power system. When transfer trip is applied, the above voltage and frequency bandwidth relays should be applied to provide backup to the transfer trip system.

It should be noted that unacceptable system voltage conditions can be created by a DG when operating normally in parallel with the power system. This type of problem can be particularly troublesome when large generators are connected near the end of relatively long radial subtransmission lines. The voltage rise that is caused by the current associated with the megawatts and megavars that are sent out by the generator as it flows across the impedance of the line can result in voltages that are excessively high. For example, consider a 60 MW generator connected at the end of a 20 mile, 69 kV line (Figure 8.19). The typical positive sequence line impedance for such a line equipped with 556 ACSR conductor would be about $3.8 + j14.4 \Omega$. Considering the generator capable of outputting 60 MW at a leading or lagging 95% power factor at the high side of its unit transformer, the voltage

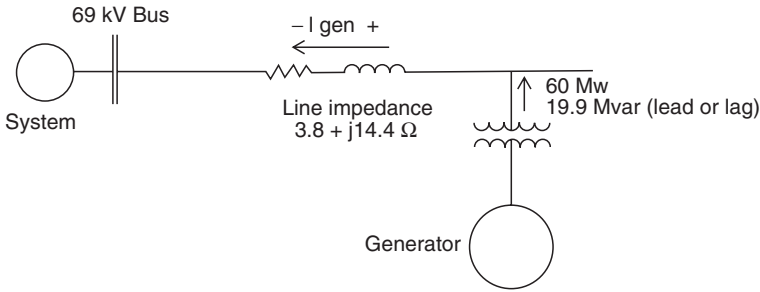

FIGURE 8.19 60 MW distributed generator connected to 20 mi radial 69 kV line.

rise on the 69 kV line at the generator location relative to the 69 kV bus voltage would be as follows:

- Generator output at transformer high side = 60 MW 19.9 mvar lagging
- Voltage rise across line impedance = 6.6%
- Generator output at transformer high side = 60 MW 19.9 mvar leading
- Voltage rise across line impedance = approximately 0%.

As indicated, depending on the power factor at which the 60 MW generator is operating, the voltage that exists on the utility line at the generator location can increase from 0% to 6.6%. Such magnitudes of voltage rise could be detrimental to power system operation. It could cause system voltages to exceed equipment ratings and can cause problems to the utility's voltage control program.

The influence that a DG can have on system voltages can be determined by conducting load flow studies. For the case of a DG connected to a radial line, a simple hand calculation can provide a good estimate of this impact. For example, following is the calculation that would be applicable for the above 60 MW generator.

- A 95% power factor equates to an 18.2° circuit angle ($\text{Cos } 18.2^\circ = 0.95$).
- Mvars = 60 MW ($\tan 18.2^\circ$) = 19.7 mvar
- Approximate current at transformer high side

$$I = \frac{60,000 \text{ kw} - j19,700 \text{ k var}}{69 \text{ kv}\sqrt{3}} = 502 - j165 \text{ A,}$$

$$V_g = 69,000 + (3.8 + j14.4 \Omega)(502 - j165 \text{ A}) = 73,580 \text{ V.}$$

As a means to avoid the potential problem stated here, the utility can provide the generator with a var output schedule designed to maintain system voltages within desired limits. The schedule would indicate the amount of vars the unit

should put out at a given megawatt output. To limit voltage rise, the generator would need to operate in the leading position when operating almost full load.

When a DG is capable of causing significant change to power system voltages, the utility may require additional voltage relaying at the inertia location to warn of an impending voltage problem. Such relaying should consist of high-accuracy voltage relays with a high pickup/dropout ratio set to alarm at voltage levels that can potentially cause operating problems to the utility systems. It is recommended that both over- and undervoltage relays be applied as the generator can cause low voltage if operating in the lead at low megawatt output. If such relays are connected to trip the generator, a very long time delay should be applied to allow operators to adjust generator output to suitable levels before allowing the relaying to initiate a trip. Such relaying is sometimes referred to as “narrow band over/under voltage relaying.”

Another potential power quality problem can be created if the DG is improperly synchronized to the system. This could result in severe voltage fluctuations at the time when the generator is connected to the system and later, if proper synchronization does not occur. Although this is undesirable from a power quality standpoint, the greater danger is to the generator itself. Improper synchronization can cause damaging transient torques in the generation system. To protect against improper synchronization of a DG, a synch-check relay is recommended to be included as part of the inertia relaying. This relay should be connected to supervise closing of all breakers that can be used to synchronize the DG to the system. Synch-check relays monitor the difference in phase angle, voltage, and frequency across the synchronizing breaker. The relay will close only if these values are within limits as established by the settings applied to the relay. Typical setting considerations:

Angle difference—10–20°

Voltage difference—5%

Slip frequency cutoff—0.1–0.15 Hz

The synch-check relay carries more value for the owner of the generator than for the utility. The owner of the generator, however, should not consider this relaying as a substitute for good synchronizing practices and controls. Modern generator controls come equipped with precise synchronizing facilities. It is important that these facilities be properly installed and calibrated, and always used, when available, in lieu of manual synchronizing.

Power system overhead lines typically employ schemes to initiate automatic reclosing subsequent to a line trip. As the majority of faults on such lines are transient in nature, automatic reclosing promotes prompt restoration of the line after the fault is cleared. When a DG is connected to a line, automatic reclosing facilities pose a hazard to the power system and to the

generator. If automatic reclosing is initiated when the generator continues to be connected to the line, consequences similar to synchronizing out-of-phase as described earlier will result. To eliminate this hazard, such schemes should be supervised with voltage relaying to assure that the line is completely de-energized before reclosing is allowed. The voltage relay should be set low (i.e., 20% normal voltage) to assure the line is de-energized and closing is safe. It should be noted that automatic reclosing supervising relays are not part of the intertie relaying package, as they must be installed at the utility substation(s) where the line breaker(s) is located. It is important for the owner of the generator to verify that such supervision is provided as it facilitates protection that is more important to the DG than to the power system itself.

8.19.2 POWER SYSTEM FAULT PROTECTION

Faults on the power system line to which a DG is connected require that tripping be initiated to isolate the generator from the power system if such isolation is required to de-energize the fault. This requirement will exist when other power system interrupting devices do not exist between the fault and the location at which the generator is interconnected to the line. Such tripping should be initiated as rapidly as possible with coordination requirements considered. Fault protection relaying is installed as part of the intertie protection package.

Phase fault protection can be obtained with the application of voltage controlled time-overcurrent relaying (51V) or time delayed distance relaying (21). A time delayed negative sequence relay (46) can be applied to enhance sensitivity for detecting multiphase faults that do not involve all three phases. Instantaneous elements of such relaying can be added as a supplement to decrease the time required for clearing some faults. Directional control can also be applied to allow increased setting sensitivity. Setting for the phase fault protective relays will depend on the characteristics of the power system and the line to which the DG is connected. It is important that the time delayed units are set with adequate sensitivity, considering infeeds from other sources of fault current that may be connected to the line, to adequately detect faults on all portions of the line for which isolation of the generator is required. Setting requirements for line fault relaying are discussed in [Chapter 12](#). It should be noted that three-phase undervoltage relaying contains the capability of detecting phase faults and can also be used for this function. The undervoltage relaying utilized for islanding protection will therefore provide some standard for phase fault protection. Application of undervoltage phase fault relaying by itself, however, is recommended only for smaller-sized DG as fault detecting capability for such relays are less precise and may require longer time delays to obtain coordination with other relaying on the power or generation system.

Intertie protection requirements for ground faults on the intertie line will depend on the connection of the transformer that connects the generator to the

power system. If the transformer connection allows for zero-sequence current flow on the power system side of the transformer, a time-overcurrent ground relay, connected to the transformer high side neutral connection or to the current transformer circuitry on a breaker connected on the power system side of the transformer, can be utilized for ground fault protection. This relaying can be made directional, if advantageous, and supplemented with an instantaneous ground unit if such application results in increased speed for clearing some faults. Transformers with both sides connected wye (grounded) will provide for the zero-sequence current flow, mentioned earlier. Wye (grounded)-delta connected transformers (delta connection on generator side) will also provide for such current flow as a transformer connected in this manner acts as a zero-sequence current source for ground faults on the power system side of the transformer. If the transformer is ungrounded on the power system side (i.e., delta-wye, delta-delta), the distributed generation facility will not provide a source of ground fault current for ground faults on the power system. When such an ungrounded source becomes isolated with a ground fault on the power system, voltage on the faulted phase will reduce to ground potential; however, the voltage to ground on the unfaulted phases will increase to as high as 173% of nominal. If the power system insulation is not rated for full phase-to-phase voltage, the increased phase-to-ground voltage can cause rapid failure of surge arresters and can cause damage to other system equipment. In such cases, the condition must be detected and removed with high speed as damage can occur in a very short period. Protection for this condition should be provided by a three-phase overvoltage relay or a voltage relay connected to sense $3V_o$ on the power system side of the transformer. A voltage relay connected inside the delta of a wye (grounded)-delta voltage transformer would effectively measure $3V_o$. A voltage relay connected within the delta of such a transformer effectively measures $V_a + V_b + V_c$. Recalling that $V_o = (V_a + V_b + V_c)/3$, the relay senses $3V_o$. The V_o during normal balanced conditions is equal to zero, therefore the $3V_o$ relay can be set at a relatively low value and provide for positive detection of a system ground fault. Ground fault overvoltage relaying needs to be set without any intentional time delay so that high-speed isolation of the generator from the fault is provided to prevent equipment damage on the power system. A high setting of around 120%–130% of nominal voltage is recommended for the overvoltage relays to prevent incorrect tripping on transient overvoltages. Care must be taken when setting overvoltage relays that are applied to detect ground faults on ungrounded systems. The load that exists on the unfaulted phases may cause the phase-to-ground voltage to be reduced considerably below the expected 173% of nominal. From this standpoint, the $3V_o$ method for detecting such faults is more reliable. If the power system equipment is rated for full phase-to-phase voltage, a high-speed scheme is not required and a time delay can be added to the voltage relays to enhance security. With time delay applied, a lower-voltage setting can be applied to the voltage relays, if

desired. In such cases, the over/under voltage relaying used for islanding protection may also be enough for providing ground fault protection.

Power directional relaying applied for anti-islanding may also operate during fault conditions. Such operation is unpredictable, however, as voltage may drop significantly during fault conditions.

8.19.3 SYSTEM PROTECTION FOR FAULTS ON DISTRIBUTED GENERATOR FACILITIES

The owner of the DG should provide protection for faults on the generation facilities, based on guidelines for generators, as they relate to the specifics of the facility that is protected. This protection should be specified to meet all related standards and requirements and should be under the control of the owner of the generator. Faults on the generation facilities should not cause any interrupting devices on the utility power system to operate other than the intertie breaker at the generator location, as tripping of power system interrupting devices would probably cause an unnecessary interruption to other utility customers. Protective relaying is applied in the intertie protection package to allow for this required coordination. This relaying will typically consist of time–overcurrent phase (51), instantaneous overcurrent phase (50), time–overcurrent ground (51N), and instantaneous overcurrent ground (50N) relays. These relays can be made directional if such action allows for setting benefits. Settings for these relays will be dictated by coordination and loading conditions at the generator facility. Once setting requirements are determined, the utility sets related protection on the intertie line to coordinate with settings on these intertie relays. For smaller units, for which a breaker on the high side of the transformer is not provided, a fuse may serve the purpose of this intertie protection. It should be noted that some utilities accept the exposure between the intertie interrupting device and the transformer high side for tripping the backup interrupting device on the power system. This exposure may be acceptable when the exposure is low and such acceptance allows for significant improvement on the protective settings required on the utility backup interrupting device. The utility backup interrupting device, however, should not be allowed to operate for faults on the generator side of the interconnecting transformer.

8.19.4 OTHER INTERTIE PROTECTION CONSIDERATIONS

Utility planning studies will assure that the power system is capable of operating within thermal limits with the DG exporting power to the system up to the contract value. Exports exceeding this value may cause thermal overloads on the power system. To protect against such overloads, power directional relays may be applied to measure power flow from the DG into the power system. A setting of about 10% above the export power limit should be applied. Such relaying will also provide a degree of anti-islanding protection as discussed earlier.

In the case of larger DG, for which angular transient stability is an issue, out-of-step relaying may be applied as part of the inertia relaying. Out-of-step relaying is discussed earlier in this chapter.

An energy source, independent of power system voltage, is required to trip breakers during fault conditions. A stored energy source such as batteries is often used for this function. Monitoring devices that assure availability of the energy source required to trip the breaker used for isolating the DG from the utility power system may be included as part of the inertia protection package.

8.19.5 INDUCTION GENERATORS

Induction generators are induction motors that are driven above synchronous speed to generate electric power. Induction generators basically do not have separate excitation systems and require that their output terminals be energized with an ac voltage and supplied with reactive power to develop the magnetic flux that is required within the machine. Induction generators are thus not capable of supplying sustained fault current for faults on the power system, to which it connects. Induction generators are generally not capable of supply isolated load when separated from the power system. It is possible for an induction generator to become self-excited if capacitors exist within the isolated system to provide a source of excitation and the isolated load is within the proximity of its rating. In many cases, when self-excitation occurs, it is accompanied by a sudden increase in terminal voltage. This increase in voltage can be quite substantial and cause damage to electrical equipment to which the induction generator is connected.

Induction generators are usually small in size and, in most cases, the amount of minimum load with which they can become isolated will not permit operation in a self-excited mode. For such installations, application of an undervoltage relay would be adequate for inertia protection. This relay would serve to disconnect the generator from the system if the inertia line trips. In cases where self-excited operation is possible, anti-islanding relaying, as provided for synchronous generators, should be provided at the inertia location. In such cases, it is important that the overvoltage relay operate instantaneously to prevent possible damage from the high voltages, which is possible when operation in a self-excited mode occurs.

8.19.6 PRACTICAL CONSIDERATIONS OF DISTRIBUTED GENERATION

Proliferation of distributed generation on power systems is changing the manner in which power systems have been traditionally configured, operated, and protected. These changes have resulted in the need for new standards to be developed so that:

1. Owners of generators are provided a fair and equal opportunity for obtaining access to power systems for transporting their generated power to prospective customers.

2. Adequate safeguards exist at the generation facility and on the associated utility power system such that the safety of personnel working at the generation site, on the power system facilities, and of the general public is uncompromised.
3. The quality of power delivered by the power system and overall power system reliability is not degraded below satisfactory levels.

Complete and technically sound standards and intertie requirements for interconnecting DG to power systems are crucial for achieving the objectives mentioned here. Various entities are involved in this process including technical societies, reliability councils, state regulatory bodies, regional transmission organizations, generation owners, and power utilities. Each of the entities involved naturally brings certain bias and self-interest into the process. It is important that the protection specialists who represent the various entities take an active role in this process and provide input to assure all pertinent protection issues identified and considered. Every power system and generation facility has some of its own unique characteristics. Engineers working directly with these systems on a continual basis are in the best position to identify hazards, concerns, and challenges as they relate to the specific system characteristics.

The discussion of this subject in this book covers common types of connections and related issues that need to be considered when designing the associated intertie protection. It is obvious that intertie protection requirements can vary considerably depending on the size and type of generator involved, the location in the power system to which it connects, and the arrangement of electrical facilities at the interconnection. Interconnection protection requirements can vary from a very simple protective system as illustrated in [Figure 8.20](#) to a much more complex system as shown in [Figure 8.21](#). Many types of generation facilities, intertie arrangements, and protection concerns that exist have not been discussed as it is beyond the scope of this book to consider all such possibilities. Power generating facilities made up of windmills, solar panels, and fuel cells undoubtedly have peculiarities that require special consideration and unique requirements. Connecting distributed generation into low tension networks causes special concerns. New types of systems are continually developed based on technological advances. The protection requirements for interconnecting distributed generation will probably need to change over time as more experience is obtained and new types of technologies are applied. Standards and requirements for interconnecting DG will require periodic review and a flexible process must be established such that changes can be made on a timely basis, as required.

8.20 PROTECTION SUMMARY

Generators, particularly very large units, are extremely critical to system operation and integrity. Thus, protection is very important for both dependability

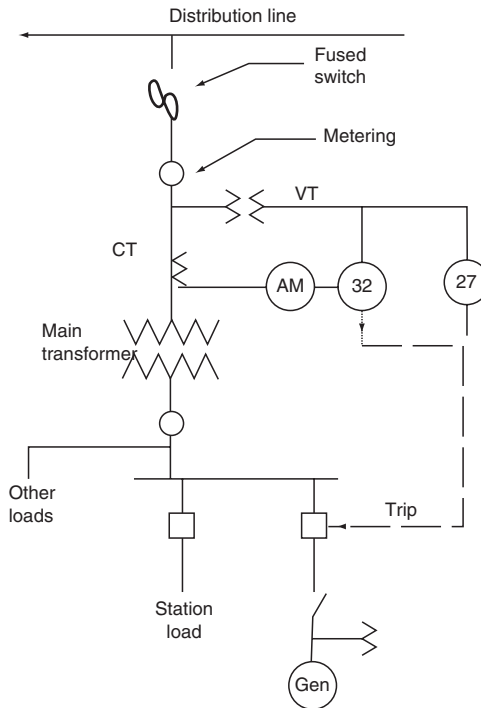

FIGURE 8.20 Possible intertie protection requirements for a small generator connected to a distribution line.

and security. Although, fortunately, fault incident is quite low, complete protection with reasonable duplication is well justified. This is the option of the particular system and individual circumstances, so any installation can show variations from others.

As has been indicated, the protection devices of [Figure 8.3](#) and [Figure 8.5](#) discussed are those applied by the user, in contrast with the protection supplied by the generator and prime-mover manufacturer. They are in common use and represent the general practices of the industry. [Figure 8.5](#) illustrates the maximum protection that would normally be applied to large and major units. [Figure 8.3](#) shows the minimum protection recommended for smaller units, especially those in industrial plants and by independent power producers. These are often relatively isolated from the large system problems.

Connections of DG to power systems have created the need for special protective systems to be applied at the intertie location. As illustrated in [Figure 8.20](#) and [Figure 8.21](#), the intertie protection requirements can vary considerably based on the characteristics of the generation facility, the

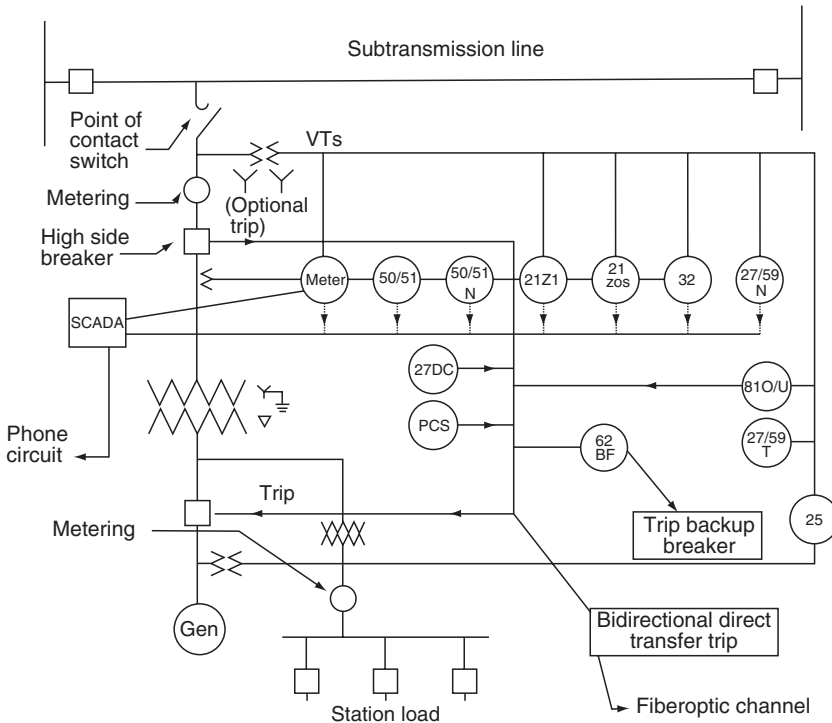

FIGURE 8.21 Intertie protection requirements for a generator connected to a subtransmission line.

interconnection, and the utility power system. Good standards covering interconnection requirements are needed to assure that safety and reliability are maintained and that a fair playing field exists for all participants in the new competitive power market.

BIBLIOGRAPHY

See Bibliography at the end of [Chapter 1](#) for additional information.

ANSI/IEEE Standard C37.102, Guide for AC Generator Protection, IEEE Service Center.

ANSI/IEEE Standard C37.106, Guide for Abnormal Frequency Protection of Power Generating Plants, IEEE Service Center.

ANSI/IEEE Standard C37.101, Generator Ground Protection Guide, IEEE Service Center.

ANSI/IEEE Standard C37.95, Guide for Protective Relaying of Utility–Consumer Interconnections, IEEE Service Center.

ANSI/IEEE Standard 1001.0, IEEE Guide for Interfacing Dispersed Storage and Generation Facilities with Electric Utility Systems.

- Ayoub, A.H., Coping with dispersed generation. *Transmission and Distribution*, January 1987, pp. 40–46.
- Cost/Risk Trade-offs of Alternate Protection Schemes for Small Power Sources Connected to an Electric Distribution System, Oak Ridge National Laboratory /Martin Marietta Energy Systems, Inc. for U.S. Department of Energy, ORNL/Sub/81-16957/1, January 1986.
- DePugh, K.S. and Apostolov, A.P., Nonutility generation interconnection guidelines of the New York State Electric & Gas Corp., Pennsylvania Electric Association Fall Conference, September 21, 1993.
- Ferro, W. and Gish, W., Overvoltages caused by DSG operation: Synchronous and induction generators, *IEEE Trans. PWRD-1*, No. 1, January 1986, pp. 258–264.
- Griffin, C.H., Relay protection of generator station service transformers, *IEEE Trans. Power Appar. Syst.*, PAS 101, 1982, pp. 2780–2789.
- Griffin, C.H. and Pope, J.W., Generator ground fault protection using overcurrent, overvoltage and undervoltage relays, *IEEE Trans. Power Appar. Syst.*, PAS 101, 1982, pp. 4490–4501.
- Gross, E.T.B. and Gulachenski, E.M., Experience on the New England system with generator protection by resonant neutral ground, *IEEE Trans. Power Appar. Syst.*, PAS 92, 1973, pp. 1186–1194.
- IEEE Intertie Protection of Consumer-Owned Sources of Generation, 3 MVA or Less, 88th 0224-6-PWR.
- IEEE Committee Report, A survey of generator back-up protection practices, *IEEE Trans. Power Deliv.*, Vol. 5, No. 2, April 1990.
- IEEE Power System Relaying Committee, Loss-of-field relay operation during system disturbances, *IEEE Trans. Power Appar. Syst.*, PAS 94, 1975, pp. 1464–1472.
- IEEE Power System Relaying Committee, Out-of-step relaying for generators, *IEEE Trans. Power Appar. Syst.*, PAS 96, 1977, pp. 1556–1564.
- IEEE Power System Relaying Committee, Potential transformer application on unit-connected generators, *IEEE Trans. Power Appar. Syst.*, PAS 91, 1972, pp. 24–28.
- IEEE Power System Relaying Committee, Protective relaying for pumped storage hydro units, *IEEE Trans. Power Appar. Syst.*, PAS 94, 1975, pp. 899–907.
- Patton, J. and Curtice, D., Analysis of utility problems associated with small wind turbine interconnections, *IEEE Trans. Vol. PAS 101*, No. 10, October 1982, pp. 3957–3966.
- Pope, J.W., A comparison of 100% stator ground fault protection schemes for generator stator windings, *IEEE Trans. Power Appar. Syst.*, PAS 103, 1984, pp. 832–840.
- Schlake, R.L., Buckley, G.W., and McPherson, G., Performance of third harmonic ground fault protection schemes for generator stator windings, *IEEE Trans. Power Appar. Syst.*, PAS 100, 1981, pp. 3195–3202.
- Wagner, C.L., et al., Relay performance in DSG islands, *IEEE Trans. Power Deliv.*, January 1989, Vol. 4, No. 1, pp. 122–131.

9 Transformer, Reactor, and Shunt Capacitor Protection

9.1 TRANSFORMERS

Transformers are everywhere—in all parts of the power system, among all voltage levels, and existing in many different sizes, types, and connections. Small transformers of about 3 to 200 kVA can be observed mounted on power distribution poles in many areas. A 325 MVA, 230–115 kV autotransformer with a 13.8 kV tertiary is shown in [Figure 9.1](#).

Usually, circuit breakers or other means of disconnection are available at or near the winding terminals of the transformer banks. However, economics sometimes dictates omission of a breaker. Thus, transformer banks can be connected directly to a bus, line, or a power source. Typical connections are illustrated in [Figure 9.2](#).

The main objective of transformer protection is to provide the ability to detect internal transformer faults with high sensitivity, along with a high degree of immunity to operation on system faults for which tripping of the transformer is not required. Sensitive detection and de-energization of internal faults will limit the internal damage caused by the fault to the transformer and the amount of subsequent repair that will be required. Various system conditions will also indirectly affect the health of transformers and need to be considered within the scope of developing comprehensive transformer protection practices. Transformer loadings that exceed transformer nameplate ratings can cause the temperature of the windings and coil to rise beyond limits. Overcurrents caused by external faults, referred to as through-fault current, can also cause excessive heating to occur within the transformer as a function of the current magnitude and duration. Such heating deteriorates insulation, which can lead to premature or immediate failure of the transformer. Overexcitation of a transformer causes eddy currents in parts of the windings to exceed design limits, which will also result in overheating. Through-fault current can also result in impact forces within the transformer,

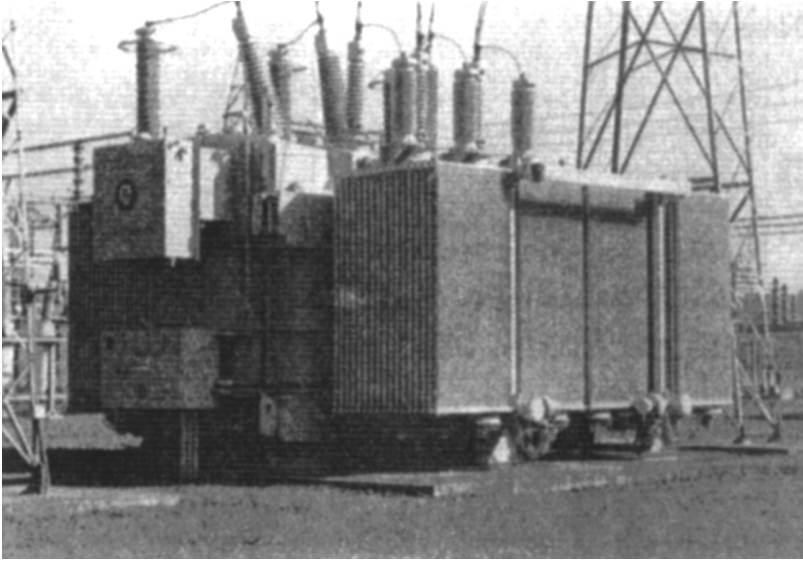

FIGURE 9.1 Three-phase 325 MVA, 230:115 kV autotransformer bank with a 13.8 kV tertiary. (Courtesy of Puget Sound Power & Light Company.)

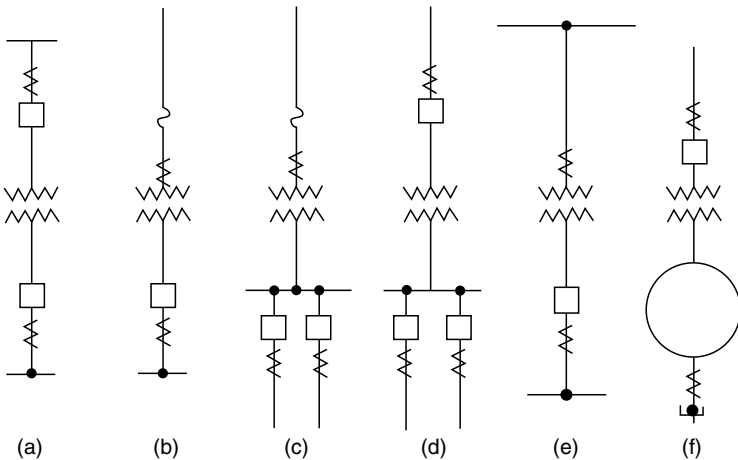

FIGURE 9.2 Typical connections of transformers in power systems: (a) used for most applications, especially at medium through EHV; (b–d) for some distribution stations; (e) for distribution circuits connected directly to a high-voltage line; and (f) for unit generators or independent power producer sources. The CTs shown are for possible applications of differential protection.

which could eventually weaken the integrity of the winding. As such, in addition to providing protection for faults, design of transformer protection also needs to consider issues related to overloads, overexcitation, and through faults.

Differential protection, wherever applicable, provides the best overall protection for both these phase and ground faults, except in ungrounded systems or in conditions where the fault current is limited by high-impedance grounding. In these latter low-ground-fault current systems, differential provides only phase-fault protection.

Generally, differential protection is applied to transformer banks of 10 MVA and above. The key is the importance of the transformer in the system, so differential may be desirable for smaller units to limit damages in critical interconnections.

In [Figure 9.2](#), the differential protective zone is between the CTs shown. Case (a) is preferred, because it provides protection for the transformer and associated breakers. Case (d) is similar, but includes the distribution bus. Paralleling the CTs in cases (c) and (d) may not be practical and can cause problems, as discussed in [Chapter 5](#).

Where fuses are used, as in cases (b) and (c), or where there is no breaker, as in case (e), differential operation must have a means of opening the fused circuit where the fault does not “blow” the fuse (b), (c), or operate remote relays (e). Several methods are used.

1. *Fault switch*: Operation of the differential closes the switch, thereby producing a fault to operate remote relays and clear the fault. Usually this is a single-line-to-ground switch, although multiphase switches have been used.
2. *Transfer trip*: The differential initiates a trip signal over a communication channel to trip the necessary remote breakers and clear the fault.
3. *Limited fault-interrupting device*: This can be used when the interrupter is unable to clear heavy faults within the differential zone and where remote-phase and ground instantaneous relays can be set into, but never through the transformer.

The differential initiates the interrupter on the basis that the remote relays will operate before the interrupter for heavy faults that would damage the interrupter. Thus, this is a race between the remote relays and the interrupter, during which the remote relays clear heavy faults first, leaving the interrupter to clear light faults. Case (f) has been discussed in [Chapter 8](#).

Overexcitation protection can be provided for by application of volts/hertz relaying or other relays connected to measure transformer excitation current. Thermal devices can be applied to provide overload protection. Overcurrent and through-fault stress protection are provided by overcurrent relaying connected to measure transformer current.

9.2 FACTORS AFFECTING DIFFERENTIAL PROTECTION

In applying differential protection, several factors must be considered:

1. Magnetizing inrush current, overexcitation, and CT saturation. These conditions can result in an unbalance to the currents applied to the relay, compared with the expected currents when power flow into the transformer is equal to the power flow out of the transformer.
2. Different voltage levels; hence, the current transformers are of different types, ratios, and performance characteristics.
3. Phase shifts in wye–delta-connected banks.
4. Transformer taps for voltage control.
5. Phase shift or voltage taps in regulating transformers.

9.3 FALSE DIFFERENTIAL CURRENT

9.3.1 MAGNETIZATION INRUSH

When system voltage is applied to a transformer at a time when normal steady-state flux should be at a different value from that existing in the transformer, a current transient occurs, known as magnetizing inrush current. This phenomenon is illustrated in [Figure 9.3](#) for a transformer with no residual flux. In the figure, the transformer is energized when the system voltage is zero. With the highly reactive circuit involved, the flux ϕ should be at or very near negative maximum, but the transformer has no flux. Thus, the flux must start at zero and reach a value of 2ϕ in the first cycle period. To provide this flux, excursion requires a large exciting current, as shown. Transformers are normally operated near saturation for best efficiency, so values of flux greater than normal ϕ result in severe saturation and a large exciting current.

If a transformer has been energized previously, there is a high possibility that on de-energization some flux ϕ_R was left in the iron. This could be positive or negative. If in [Figure 9.3](#), a residual flux of $+\phi_R$ had existed from an earlier energization, the flux maximum required would have been $2\phi + \phi_R$, resulting in a higher maximum magnetizing inrush current. If ϕ_R had been negative, the maximum required flux would be $2\phi - \phi_R$ with less inrush current.

This is a random phenomenon. If the transformer had been energized at or near maximum positive voltage (see point d in [Figure 9.3](#)), the flux requirement at that time is zero. Thus, normal exciting current would flow with negligible or no transient inrush. Normal exciting currents for power transformers are on the order of 2%–5% of full-load current.

The maximum initial-magnetizing current may be as high as 8–30 times the full-load current. Resistance in the supply circuit and transformer and the

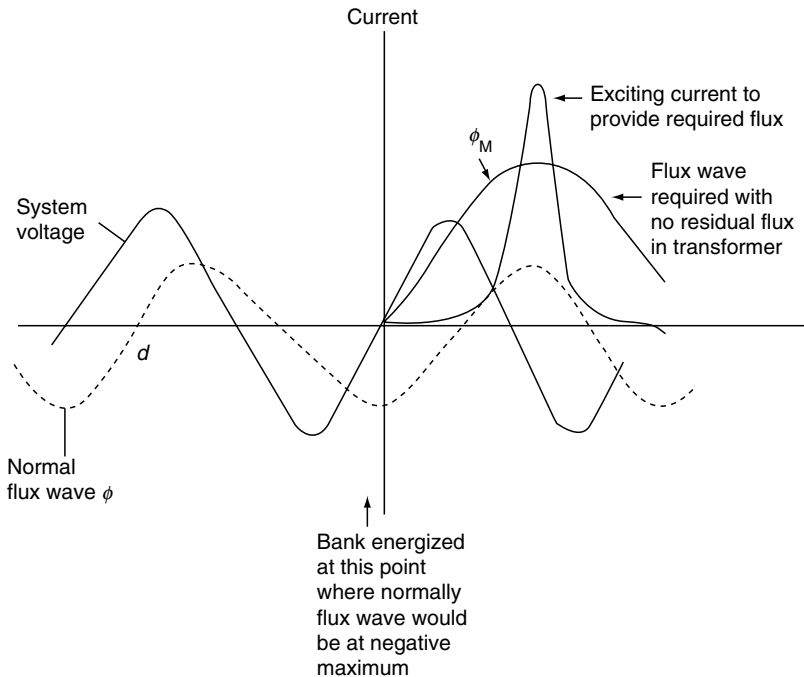

FIGURE 9.3 Magnetizing inrush current phenomenon (no residual flux initially in transformer).

stray losses in the transformer reduce the peaks of the inrush current such that, eventually, it decays to the normal exciting current value. The time constant varies from about 10 cycles to as long as 1 min in very high-inductive circuits.

The factors involved in the inrush, in addition to the time point of energization with relation to the flux requirements, are the size of the transformer, the size and nature of the power system source, the type of iron in the transformer, previous history, and the L/R ratio of the transformer and system.

In a three-phase circuit, some inrush will always occur in one or two and generally all three phases, with the voltages at 120° apart, although it may or may not be maximum or zero in one of the phases. Figure 9.4 shows a typical magnetizing inrush current trace when a transformer bank is energized from either the wye- or delta-connected terminals. Some years ago, studies indicated that the second-harmonic component of the inrush wave was 15% or more of the fundamental current. In recent years, improvements in core steel and design are resulting in transformers for which all inrush current harmonics are less, with possibilities of the second harmonic being as low as 7%.

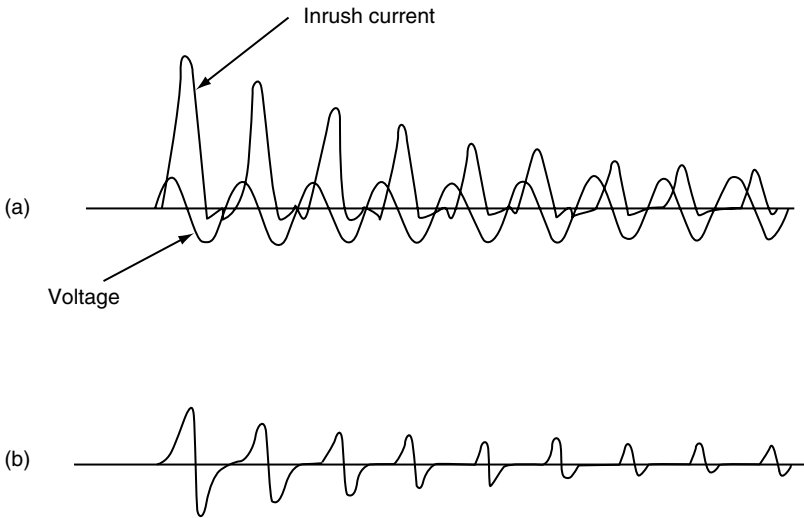

FIGURE 9.4 Typical magnetizing inrush current to transformers: (a) A-phase current to wye-connected windings; (b) A-phase current to delta-connected windings.

Magnetizing inrush can occur under three conditions and are described as (1) initial, (2) recover, and (3) sympathetic.

1. The initial-magnetizing inrush may occur when energizing the transformer after a previous period of de-energization. This was described earlier and has the potential of producing the maximum value.
2. During a fault or momentary dip in voltage, an inrush may occur when the voltage returns to normal. This is called the recovery inrush. The worst case is a solid three-phase external fault near the transformer bank. During the fault, the voltage is reduced to nearly zero on the bank; then, when the fault is cleared, the voltage suddenly returns to a normal value. This may produce a magnetizing inrush, but its maximum will not be as high as the initial inrush because the transformer is partially energized.
3. A magnetizing inrush can occur in an energized transformer when a nearby transformer is energized. A common case is paralleling a second transformer bank with one already in operation. The DC component of the inrush current can also saturate the energized transformers, resulting in an apparent inrush current. This transient current, when added to the inrush current of the bank that is energized, provides an offset symmetrical total current that is very low in harmonics. This would be the current flowing in the supply circuit to both transformer banks.

9.3.2 OVEREXCITATION

The flux level within a transformer is proportional to the voltage applied to the transformer and inversely proportional to the frequency of the applied voltage. When overexcitation conditions that are above transformer design limits occur, the transformer core becomes saturated resulting in a buildup of heat with eventual damage to the transformer.

Generator transformers are especially subject to overexcitation as such transformers are connected directly to the generator terminals. Voltage and frequency conditions at the generator terminals are subject to voltage and frequency variations, especially during startup of the generator. Overexcitation protection for generator unit transformers was discussed in [Chapter 8](#). Transformer overexcitation concerns, however, are not limited to generator transformers. Overvoltage and underfrequency conditions can occur anywhere on the power system, especially when disturbances cause portions of the system to operate as isolated islands. Bulk transmission systems are also subject to high-voltage conditions during light load periods. This is because such systems often contain long transmission lines, which contain significant capacitance. During light load periods, the effect of line capacitance predominates voltage drops caused by load flowing through the inductive reactance of the line, resulting in increased voltage levels on the system. Voltage levels can increase to the point where the ratings of system facilities, including transformers, are exceeded.

Harmonic content of transformer excitation current is predominantly odd harmonic. Typical transformer excitation current will contain a fundamental component, which is 52% of nominal, a third harmonic component equal to 26% of nominal, a fifth harmonic component equal to 11% of nominal, a seventh harmonic component equal to 4% of nominal, and so on.

Overexcitation protection should be considered for all large transformers utilized as generator unit transformers or those that are connected to portions of the power system conducive to causing transformers to become overexcited. Such protection should consist of relaying that is capable of directly responding to the level of excitation that exists such as volts/hertz relaying as discussed in [Chapter 8](#). Transformer differential relays are subjected to operation on high transformer excitation current. However, the operating characteristic of the relay on such current does not correlate well with transformer overexcitation limit characteristics. As such, it is not practical to use differential relaying as a means to protect transformers against overexcitation. On the downside, transformer differential relays are subject to operating on overexcitation current at levels below that which may cause damage to the transformer. Moreover, operation of differential relaying caused by overexcitation could cause confusion to postdisturbance investigations. Larger transformers, for which overexcitation is a concern, should be equipped with dedicated overexcitation protection and associated differential

relaying should be blocked from operating on excitation current for reasons cited earlier.

9.3.3 CURRENT TRANSFORMER SATURATION

Saturation of current transformers associated with transformer differential relaying causes several concerns with regard to such relaying:

1. CT saturation on external faults can cause incorrect operation of differential relaying due to operating current that can result from the distorted secondary current waveforms that exist during such conditions.
2. The harmonics contained in secondary currents of a saturated current transformer may delay operation of transformer differential relaying on internal transformer faults.

Proper selection of current transformers, as discussed later in this chapter, will minimize exposure to the problems listed earlier. Design features of transformer differential relays also address these concerns.

9.4 TRANSFORMER DIFFERENTIAL RELAY CHARACTERISTICS

The basic principles of differential relays and protection were outlined in [Chapter 6](#). For applications to transformers, the differential relays are less sensitive and with typical percentage characteristics between 15% and 60%. This provides accommodation for the different CT ratios, types, and characteristics, different primary current energization levels, and for transformer taps, wherever they exist.

This applies to both electromechanical and modern microprocessor based relays. The latter, although operating on the fundamental differential principle, may not have restrained and operating “coils,” but may make the comparison through numerical manipulation within the microprocessor. Solid-state and microprocessor based transformer differential relays provide harmonic restraint, whereas electromechanical relays may or may not have this feature.

For smaller transformers, particularly in the lower-voltage subtransmission and distribution systems, induction-disk electromechanical transformer relays were often applied in the past. Many of these relays remain in service in recent times. With a 50% characteristic and operating time of about 0.08–0.10 sec (five to six cycles in 60 Hz systems), good immunity to magnetizing inrush was provided. Generally, in these areas, the inrush is not too severe and there is sufficient resistance in the system to rapidly dampen the transient. The induction-disk unit does not operate very efficiently on this high, distorted offset wave, and does not operate on DC. The advantage was a

relatively simple rugged design and low cost. However, it is not possible to assure that the relay will never operate on inrush, although experience can show it to be immune. It has been observed that this type of relay “has a long and enviable record” of good performance, which accounts for the reluctance to replace such relaying. Typical pickup current is 2.5–3.0 A.

As time progressed, more advanced designs of transformer differential relays emerged to meet industry needs for protecting larger, more expensive, transformers that were purchased to serve as generator unit transformers and for transformation needs on high-voltage bulk power systems. Various features were incorporated into the design of transformer differential relays to allow for greater setting sensitivity and for faster operating times:

1. Harmonic restraint was added to make the transformer differential relay less likely to operate on transformer inrush current. Typical designs use second harmonic for restraining operation, as it is the major harmonic component of transformer inrush current. Utilization of restraint on fourth harmonic in addition to second will result in additional security against operation on inrush current.
2. A “blocking” feature is provided upon detection of fifth harmonic content in the differential current. This design feature blocks a trip output from the transformer differential relay and is intended to prevent operation of this relay on transformer excitation current. Fifth harmonic is used for this blocking function rather than the third harmonic because the presence of delta-connected current transformers in the differential scheme will filter the third harmonic content. This feature is often made optional to the user as it may not be desired if other forms of overexcitation protection are not being applied on the transformer.
3. Transformer differential relays are designed with “variable” percentage differential characteristics to lower the probability for operation when current transformer saturation occurs during faults that are external to the zone protected by the differential relay. In such designs, the slope of the differential characteristic increases as current to the relay increases. The increase in slope may be continual or in steps. Current transformer saturation is most likely to occur during high fault current conditions. This design allows for a larger percentage-of-error current as the current magnitude for external faults increases. An instantaneous operating unit is added to allow unrestrained high-speed operation on internal faults that cause high current flows.

Modern microprocessor based transformer differential relays provide a high degree of flexibility for incorporating a multitude of design features that were not formerly possible with electromechanical or solid-state designs. In addition, such relays provide for a wide range of settings along with a variety of setting options. Calculations to account for different current transformer

connections can be made internally with the microprocessor eliminating the need for making such connections external to the relay. Modern microprocessor based transformer differential relays will normally incorporate design features as described earlier along with other enhancements designed to provide additional operational improvements. Such designs are capable of providing secure operation with sensitivities down to 0.75 A or less and with operating times as fast as one cycle or less.

9.5 APPLICATION AND CONNECTION OF TRANSFORMER DIFFERENTIAL RELAYS

The differential protective zone must always account for all circuits into or out of the zone, with one unit per phase for the zone. For two-winding transformers with a single set of CTs associated with the windings, a two-restraint relay (see Figure 6.2) is applicable. For multiwinding transformers, such as three-winding banks, autotransformers with tertiary winding connected to external circuits, or where double breakers and CTs supply a single winding (as in a ring bus or breaker-and-a-half arrangement), a multiple restraint winding relay should be used. Differential relays are available with two, three, four, and up to six restraint windings, with a single-operating winding. The characteristics are similar to those described in the foregoing.

The important fundamentals of application are

1. Use a restraint winding for each fault source circuit.
2. Avoid paralleling the CTs of a feeder (no-fault source) with CTs of a fault source.
3. Parallel feeder CTs carefully.

The reasons for and the logic of these will be apparent later.

The currents through the differential relay-restraint windings should be in phase, and there should be a minimum difference (operating) current for load and external faults. Ideally, this difference should be zero, but with different CT ratios on the different voltage levels; practically, this is usually impossible. This suggests two steps for correctly connecting and setting transformer differential relays:

1. *Phasing*: By using wye–delta units, to assure that the secondary currents to the differential relay are in phase.
2. *Ratio adjustment*: By selecting CT ratios or relay taps, or both, to minimize the difference current that will flow in the operating circuit.

The recommendations and criteria just given are best explained by typical examples.

9.6 EXAMPLE: DIFFERENTIAL PROTECTION CONNECTIONS FOR A TWO-WINDING WYE-DELTA TRANSFORMER BANK

Consider a delta-*abc*-connected transformer bank (Figure 9.5). The ABC delta leads the *abc* wye by 30°; thus, following the ANSI standard, ABC represents the high-voltage 138 kV side, and *abc* is the low-voltage 69 kV side.

Secondary currents in phase on the differential relay could be provided by connecting the *abc* set of CTs in wye or in delta with the ABC set of CTs in delta or wye, respectively. However, connecting the *abc* CTs in wye would result in incorrect operation for external ground faults. Zero-sequence current supplied by the transformer-grounded wye to external faults in the *abc* system can flow through the wye-connected *abc* CTs to the relay-restraint coil returning through the operating coil. This is because the zero-sequence current circulates in the transformer delta and does not flow in the ABC system to provide proper external fault-balancing restraint. Therefore, the CTs on wye transformer windings should be connected in delta. This provides a zero-sequence circulating path within the CT connection so that it cannot flow in the relays.

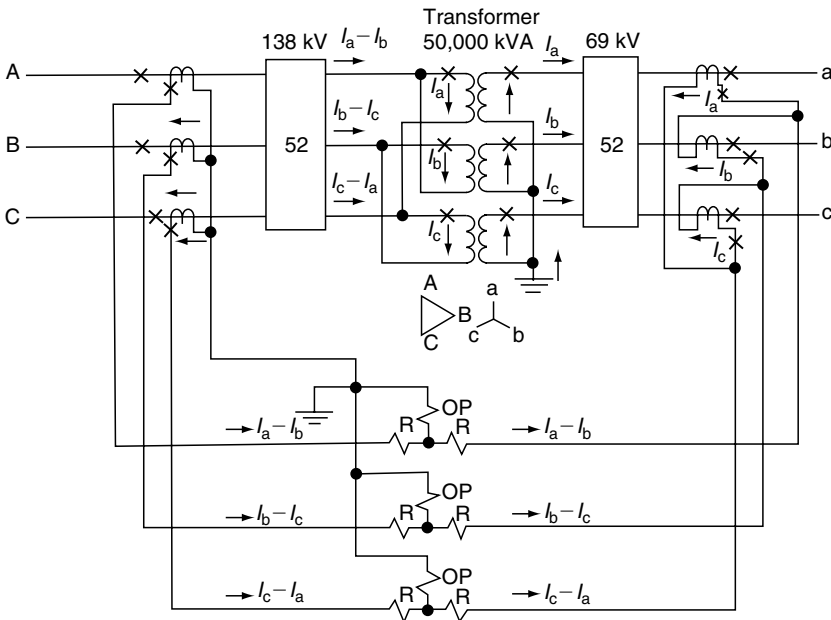

FIGURE 9.5 Differential relay connections for the protection of a two-winding transformer bank.

9.6.1 FIRST STEP: PHASING

The two sets of CTs must be connected so that the secondary currents to the relay-restraint windings are in phase for through load or any external fault. Assume balanced three-phase currents flowing through the transformer. The direction is not important as long as the currents flow through the bank. It is desirable and easiest to start on the transformer wye side, so in Figure 9.5, assume that I_a , I_b , and I_c flow in the wye and to the right into the abc system as shown. With transformer polarity as shown, these currents appear in the high-voltage windings, and with the delta connected as shown appear in the high-voltage ABC system as $I_a - I_b$, $I_b - I_c$, and $I_c - I_a$, flowing consistently to the right in the A, B, and C phases, respectively.

With the abc, CTs to be connected in delta as explained in the foregoing, the ABC CTs will be connected in wye. With the CT polarity as shown, secondary $I_a - I_b$, $I_b - I_c$, and $I_c - I_a$ flow to the differential relay-restraint coils. For the external condition, these currents should flow out of the other restraint coils and to the right. Back to the wye abc side, I_a , I_b , and I_c currents flow to the left in the CT secondaries. The last part is to connect these abc CTs in delta to provide the proper restraint secondary currents. This completes the first and phasing step.

In summary, this phasing was done by assuming balanced current flow in the transformer wye circuit, transferring these currents through the transformer to the delta side, connecting the delta-side CTs in wye and to the relay-restraint coil, carrying these currents through the relays to the other restraint coils, and connecting the wye transformer-side CTs in delta to provide these restraint coil currents.

If the transformer bank had been connected in delta on both sides, the CTs on both sides could be connected in wye to the differential relays.

For wye-grounded–wye-grounded transformer banks without a tertiary, or with a tertiary not brought out to terminals, delta-connected CTs on both sides must be used. It would be possible to use wye-connected CTs if the bank consisted of three independent two-winding transformers connected wye-grounded–wye-grounded. However, if this type of bank was a three-phase type (all three phases in a common tank), then the delta-connected CTs are recommended. In these three-phase units, there is always the possibility of a phantom tertiary resulting from the interaction of the fluxes because of the construction. The key is always that if wye CT connections are used, the per-unit zero-sequence current must be equal on both sides of the bank for all external faults. The delta CT connection is safer, as it eliminates zero sequence from the relays.

At this point, the question might arise: do the transformer differential relays provide protection for ground faults with delta-connected CTs? The answer is that, for ground faults, the relays can operate on the positive- and negative-sequence currents involved in these faults. The differential relays

operate on the total fault components for internal faults. Thus, for a single-line-to-ground fault the total fault current is $I_1 + I_2 + I_0$ and $I_1 = I_2 = I_0$, so the differential relay with delta CTs will receive $I_1 + I_2$ or $2I_1$ for the internal fault.

With reference to [Figure 9.5](#), an internal single-line-to-ground fault on the 69 kV side would be fed by positive- and negative-sequence currents from the 138 kV source, and positive-, negative-, and zero-sequence currents from the 69 kV source. The delta-connected 69 kV CTs eliminate the 69 kV zero-sequence current, but the sum of the positive and negative sequence from the 138 kV and 69 kV sources both add to flow through the relay-operating windings.

For an internal phase-to-ground fault on the 138 kV side, positive- and negative-sequence currents are supplied from the 69 kV source, and all three sequence components from the 138 kV source. In this case, the differential relays receive the total $I_1 + I_2 + I_0$ fault current with the 138 kV wye-connected CTs.

9.6.2 SECOND STEP: CT RATIO AND TAP SELECTIONS

It is important to minimize the unbalanced current flowing through the operating coils for loads and external faults. Most transformer differential relays have taps available to assist in the process. These provide for differences in the restraint current in the order of 2:1 or 3:1. The percentage mismatch (M) can be expressed as

$$M = 10 \times \frac{\frac{I_H}{I_L} - \frac{T_H}{T_L}}{S}, \quad (9.1)$$

where I_H and T_H are secondary current and relay tap associated with the high-voltage (H) winding; I_L and T_L the secondary current and relay tap associated with the low-voltage (L) winding; and S the smaller of the current or tap ratios in the formula. The sign of the subtraction is not significant, so if T_H/T_L is greater than I_H/I_L , the subtraction can be made to give a positive number.

The rated currents in the 50 MVA transformer are

$$I_H = \frac{50,000}{\sqrt{3} \times 138} = 209.18 \text{ primary amperes at 138 kV.} \quad (9.2)$$

Choose a 250:5 CT ratio, which gives

$$I_H = \frac{209.18}{50} = 4.18 \text{ secondary amperes in the left-hand} \\ \text{restraint winding of Figure 9.5,} \quad (9.3)$$

$$I_L = \frac{50,000}{\sqrt{3} \times 69} = 418.37 \text{ primary amperes at 69 kV.} \quad (9.4)$$

Choose a 500:5 CT ratio, which gives

$$\begin{aligned} I_L &= \frac{418.37}{100} = 4.18 \text{ secondary amperes in the 69 kV CT secondaries,} \\ &= 4.18\sqrt{3} = 7.25 \text{ secondary amperes in the right-hand} \\ &\quad \text{restraint windings of Figure 9.5,} \end{aligned} \quad (9.5)$$

$$\frac{I_H}{I_L} = \frac{4.18}{7.25} = 0.577. \quad (9.6)$$

Suppose that the particular relay used has the possibility of $T_H = 5$ and $T_L = 9$, which provides

$$\frac{T_H}{T_L} = \frac{5}{9} = 0.556. \quad (9.7)$$

Then for this application the percentage mismatch (see Equation 9.1) is

$$M = 100 \frac{0.577 - 0.556}{0.556} = 3.78\%. \quad (9.8)$$

This is a good match. With transformer differential relays having percentage characteristics between 20% and 60%, 3.78% provides ample safety margin for unanticipated CT and relay differences and performance errors. Theoretically, this mismatch could closely approach the specified percentage of the differential relay, which would then reduce the safety margin correspondingly.

In selecting these CT ratios, it is desirable to keep the ratio as low as possible for higher sensitivity, but (1) not to have the maximum load exceed the CT or relay continuous current ratings, as provided by the manufacturers, and (2) the maximum symmetrical external fault should not cause a current transformer ratio error of more than 10%.

For (1), the maximum load should be the highest current, including short-time emergency operation. Transformers often have several ratings: normal, with fans, with forced circulation, and so on. For most transformer differential relays, the restraint coils have continuous ratings of 10 A or more.

For (2), the performance of current transformers is covered in Chapter 5 and is applicable here. In general, the burdens of differential relays for external fault conditions are very low. It is an accepted practice to use a

separate set of CTs for differential protection and not connect, or at least minimize, any other relays or equipment in these circuits. This provides a minimum and low total burden to aid the current transformer performance.

In addition, the current through the differential for the external fault is only that part of the total fault current that flows through the transformer bank to the fault. Thus, it is limited by the transformer bank impedance. In contrast, the internal fault is the total fault current, but in this situation, not all of the total flows through any set of CTs, except for a single fault source. Some saturation of the CTs may occur for the internal fault. Although this is not desirable, probably there will not be relay-operating problems unless the saturation is very severe, because the fault-operating current is usually many times greater than the relay pickup current.

9.7 LOAD TAP-CHANGING TRANSFORMERS

Usually, these taps provide the possibility of modifying the voltage ratio 10% for voltage or var control. Differential relays can be applied as discussed earlier. The CT ratio and relay tap selection should be made at the midpoint of the tap-changing range and with a low value of M . The sum of M and one-half of the tap range must be within the relay percentage characteristics. Thus, in the example of [Figure 9.5](#), assuming that this bank has 10% taps for changing the 69 kV voltages to a maximum of +10% or a minimum of -10%, with the ratios and taps selected at the 69 kV midpoint of the tap range, an M value of 3.78% was determined (see [Equation 9.8](#)). With the transformer taps, the maximum mismatch is 13.78%, which would occur on the maximum or minimum voltage tap. This value is still within the percentage differential characteristics of applicable relays.

9.8 EXAMPLE: DIFFERENTIAL PROTECTION CONNECTIONS FOR MULTI-WINDING TRANSFORMER BANK

[Figure 9.6](#) shows a three-winding wye-delta-wye transformer bank. This discussion also applies to an autotransformer with a delta tertiary. With three windings connected to external circuits, three restraint transformer differential relays are required. There should be a set of CTs in each circuit, connected to a separate restraint winding. Thus, the protective zone is the area among these several CTs.

The two-winding-type differential relay may be applied to multiwinding transformers if

1. The third winding is a tertiary and not brought out to external circuits.
2. The circuits connected to the third or tertiary winding are considered as part of the protective zone. This might be where there is no adequate breaker, or the winding feeds the transformer's auxiliaries, and so on.

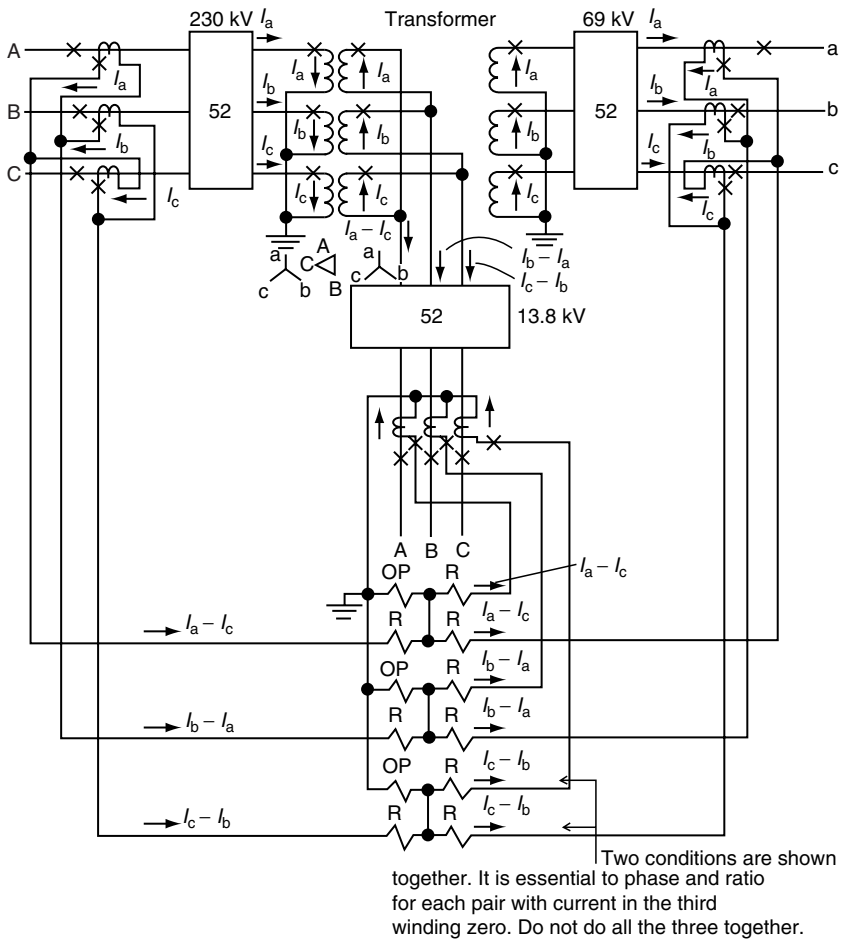

FIGURE 9.6 Differential relay connections for the protection of a three-winding transformer bank. Some connections applicable for an autotransformer with delta tertiary.

3. The tertiary winding has a very high reactance, such that faults on the associated system would not be large enough in magnitude to operate the transformer differential relays.

The two steps (1) phasing and (2) CT ratio and tap selection are applicable to the multiwinding applications. It is very important, indeed essential, that these, particularly the second, be done in pairs, that is, connect and set the

CTs and relays of any two transformer windings, ignoring and assuming zero current in the other windings. Then repeat for another winding pair. An example will amplify this.

In Figure 9.6, there are two grounded wye windings and one delta winding. From previous discussions, the CTs in the wye-connected winding should be connected in delta to avoid operation on external ground faults. The CTs in the delta-connected winding circuit would be connected in a star configuration to accommodate the 30° phase shift. The first-step phasing is to choose a pair. Although this is arbitrary, for this example, the pair should include the delta and one of the wye windings.

Start with the left-hand wye winding and assume that balanced currents I_a , I_b , and I_c flow to the right. They pass through the wye–delta-winding pair and into the ABC system as $I_a - I_c$, $I_b - I_a$, and $I_c - I_b$. The current in the right-hand wye winding is assumed to be zero. The wye-connected CTs on the ABC system provide the same currents on a secondary basis in the differential relay-restraint windings. These secondary currents must be supplied through the left-hand restraint windings. This is accomplished by connecting the CTs in delta as shown.

With this phasing complete, the second pair could be the left-hand star winding just connected and the right-hand wye winding with zero in the delta circuit. Next, the $I_z - I_c$ in the left-hand winding restraint coil must flow out of the right-hand and wye-winding restraint coil; correspondingly, for $I_b - I_a$ and $I_c - I_b$. With I_a , I_b , and I_c flowing to the right out of the right-hand wye winding, the CTs can be connected as required in delta. This completes the first step.

Multiwinding transformer banks usually have different MVA ratings for the several windings, and these are used to determine the CT ratios. Suppose that Figure 9.6 bank ratings are 60, 40, and 25 MVA for the 230, 69, and 13.8 kV windings, respectively, then the rated current for the windings would be

$$I_H = \frac{60,000}{\sqrt{3} \times 230} = 150.61 \text{ A at } 239 \text{ kV.} \quad (9.9)$$

Choosing a 150:5 CT ratio, the secondary currents are

$$\begin{aligned} I_H &= \frac{150.61}{30} = 5.02 \text{ A secondary} \\ &= 5.02 \times \sqrt{3} = 8.70 \text{ A in the restraint winding,} \end{aligned} \quad (9.10)$$

$$I_M = \frac{40,000}{\sqrt{3} \times 69} = 334.70 \text{ A at } 69 \text{ kV.} \quad (9.11)$$

Choosing a 400:5 CT ratio, the secondary currents are

$$\begin{aligned} I_M &= \frac{334.70}{80} = 4.18 \text{ A secondary} \\ &= 4.18 \times \sqrt{3} = 7.25 \text{ relay amperes,} \end{aligned} \quad (9.12)$$

$$I_L = \frac{25,000}{\sqrt{3} \times 13.8} = 1045.92 \text{ A at 13.8 kV.} \quad (9.13)$$

Choosing a 1200:5 CT ratio, the secondary currents are

$$I_L = \frac{1045.92}{240} = 4.36 \text{ A in CT and relay.} \quad (9.14)$$

These rated currents are useful in selecting the CT ratios, but are not usable as such in selecting relay taps and calculating mismatch. It is essential for these to select any value of MVA and pass it through the pairs with zero MVA in the other winding (s). Only if this is done will the differential relay balance correctly for any combination of current division during loads and faults, including one winding out of service. The value chosen is not important for this part; therefore, for example, assume that 40 MVA first flows from the 230 to 69 V systems with zero in the 13.8 kV system. This is convenient and Equation 9.12 gives the current in the left restraint coil. In the 230 kV right restraint coil, the current to be balanced is

$$I_{230} = \frac{40,000}{\sqrt{3} \times 230(30)} \sqrt{3} = 5.80 \text{ A secondary.} \quad (9.15)$$

Suppose the particular relay has taps, including 5 and 6. Using these, the percentage mismatch (see Equation 9.1) is

$$M = \frac{(5.8/7.25) - (5/6)}{0.8} \times 100 = \frac{0.80 - 0.83}{0.80} \times 100 = 4.17\%. \quad (9.16)$$

This is well within transformer differential relay characteristics. With tap 5 for the 230 kV restraint winding, and tap 6 for the 69 kV restraint winding established, pass equal MVA through another pair, arbitrarily select 25 MVA from the 230 to 13.8 kV system, which gives 4.36 A (see Equation 9.14) in the 13.8 kV restraint. Correspondingly, in the 230 kV restraint,

$$I_{230} = \frac{25,000}{\sqrt{3} \times 230(30)} \sqrt{3} = 3.62 \text{ A secondary.} \quad (9.17)$$

Choose tap 6 for the 13.8 kV restraint; then the mismatch from Equation 9.1 is

$$M = \frac{\left(\frac{3.62}{4.36}\right) - \left(\frac{5}{6}\right)}{0.83} \times 100 = \frac{0.83 - 0.83}{0.83} \times 100 = 0\%, \quad (9.18)$$

where the CTs are matched. In selecting taps as available on the particular transformer differential relay, a check should be made that the maximum load currents (see Equation 9.10, Equation 9.12, and Equation 9.14) do not exceed the continuous current ratings of the manufacturer.

This completes the second step. However, selecting the settings in pairs as described will give proper operation (no trip) for any mix of load or fault currents among the several windings. The final step is to assure current transformers performance for external as well as internal faults, as outlined in Section 9.6.2.

9.9 APPLICATION OF AUXILIARIES FOR CURRENT BALANCING

At times, it may not be possible to obtain an acceptable value of mismatch with the available CTs or differential relay taps. These cases require the use of auxiliary CTs or current-balance transformers. It is preferable in applying these to reduce the current to the relays if possible. Reducing the secondary current to the relays reduces the relay burden by the square of the current ratio. When the current is increased to the relays, the relay burden is increased by the current ratio squared. This does not include the burden of the auxiliaries, which must be added to the total secondary load on the current transformers.

9.10 PARALLELING CTs IN DIFFERENTIAL CIRCUITS

In Section 9.5, it was recommended to use a restraint coil for each source and to avoid paralleling a source and feeder. This is sometimes considered or done for a multiwinding bank or where two banks are in the same protective zone. The difficulties that may be experienced are illustrated in Figure 9.7. There is no problem in paralleling two sets of CTs, such as shown, as long as all three winding circuits of the transformer are in service. However, with the possibility of emergency operation, during which the left-hand breaker is open, restraint is lost and the differential relays are operated as sensitive overcurrent units. As shown in Figure 9.7a, current flow from the right-hand source to the feeder should net zero. This is difficult with different CTs and voltage levels. Even with a perfect match, the difference in the CT exciting currents will flow to the differential relay, as explained in Chapter 6. In other words, there is no

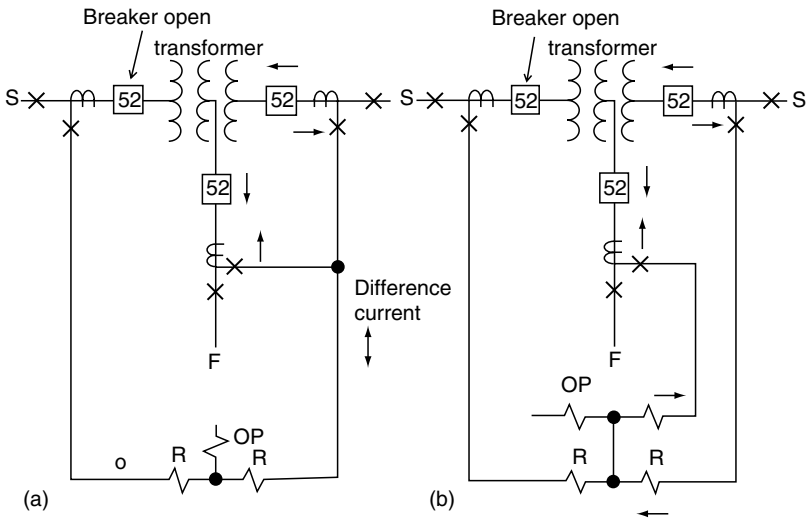

FIGURE 9.7 Potential loss of restraint that may result by paralleling circuits in differential protection: (a) no restraint; (b) full restraint (S, source of fault current; F, feeder—no significant fault source).

effective restraint for this condition. This connection might be marginally safe for normal-load flow, but is subject to misoperation for external faults out on the feeder.

Paralleling the CTs may be done if the transformer would never be operated with the left-hand breaker open. It is not recommended, as there is always the possibility that during an unusual emergency situation, operators may resort to unplanned opening of the left-hand breaker. In contrast, with the recommended restraint for each circuit (see Figure 9.7b), full restraint exists, as shown.

Feeder circuit CTs may be paralleled in a differential scheme as long as there is negligible fault current supplied through them. Caution should be exercised, recognizing that for external faults out on one of the feeders, some of the secondary current required for balancing the differential is diverted to magnetize those other feeder CTs that are not supplying primary current. This is discussed in Chapter 5.

Typical examples of transformers with multiple circuits are illustrated in Figure 9.8. As recommended and shown, each circuit should be connected to an individual restraint winding in the differential relay, following the procedure outlined earlier. Paralleling of circuits and CTs should be avoided, but when necessary, the problems discussed should be considered carefully and documented by the operating personnel.

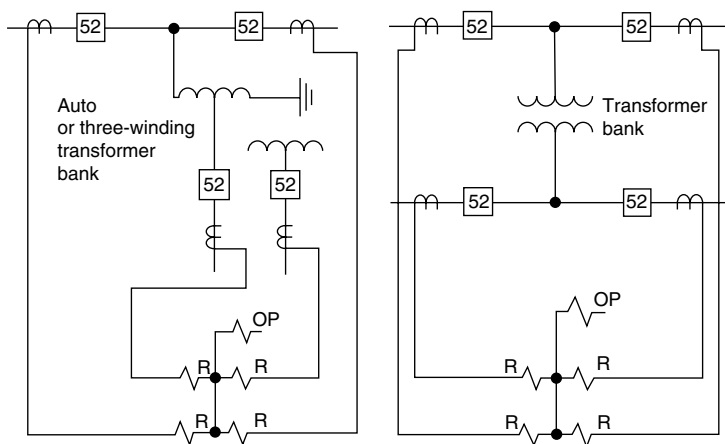

FIGURE 9.8 Single-line differential connections for multiple connections to transformers.

9.11 SPECIAL CONNECTIONS FOR TRANSFORMER DIFFERENTIAL RELAYS

Occasionally, it may be necessary to use star-connected CTs on a grounded-wye circuit in a differential scheme instead of the preferred delta CT connection. This can occur in applications for which a differential zone is established around several banks. For these, the first consideration is the possibility of a sympathetic inrush. The zone should be examined to see if there is any possible operating condition, during which one bank can be energized, followed by energizing a second bank. If all banks in the protection zone are always energized together, sympathetic inrush will not occur, and a single differential relay application is possible. Most of these cases are the result of the omission of circuit breakers and associated CTs for cost saving, but at the expense of less flexible system operation.

Figure 9.9 shows the connection of a zero-sequence trap to divert the zero-sequence current from the differential relay with wye-connected CTs on the grounded side of the transformer. It is essential in these types of connections (for any connections) that a path exists for zero-sequence current flowing into or out of a bank in the CT secondaries. This is provided by the trap, as shown. If a proper path is not available in the CT secondaries, the equivalent of an open secondary circuit exists, with resulting saturation and high and dangerous voltages. This is true for positive, negative, as well as zero sequences; the absence of a proper path for zero sequence would be apparent only on the occurrence of a ground fault in the otherwise balanced system.

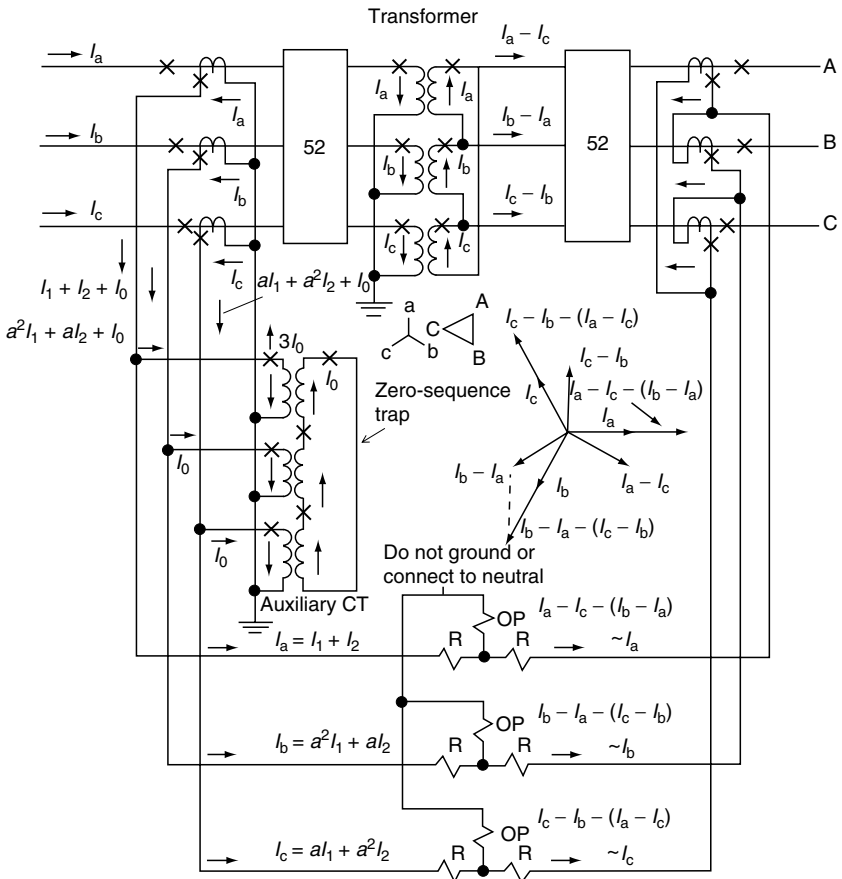

FIGURE 9.9 Special differential connections using star-connected CTs on the transformer-grounded wye terminals.

The zero-sequence trap consists of three auxiliary CTs. Their ratio is not important as long as they are the same. Note that the operating coil neutral is not connected to the CT neutral or grounded. It is not necessary for a zero-sequence current flow to have correct relay operation. Connecting this operating coil neutral to the CT neutral places the restraint and operating coil windings in parallel with the primary winding of the trap. This could cause enough diversion of current for an external ground fault and relay misoperation.

With the left-hand CTs connected in wye (see Figure 9.9), it is necessary to connect the right-hand CTs in delta properly to provide currents in phase

through the differential relay for external primary current flow. This phasing should be done as in the foregoing, starting with balanced I_a , I_b , and I_c currents into (or out of, if preferred) the wye transformer windings. Carrying this through it can be seen with a phasor diagram that $(I_a - I_c) - (I_b - I_a)$ is in phase with I_a , and similarly for the other phases. The per-unit magnitudes are three times larger, but this can be adjusted by the CT and relay taps. Ground faults within this differential zone will operate the relays through the positive and negative fault current components (see Figure 9.9).

9.12 DIFFERENTIAL PROTECTION FOR THREE-PHASE BANKS OF SINGLE-PHASE TRANSFORMER UNITS

Single-phase transformer units are connected in various three-phase configurations, usually wye–delta and with associated circuit breakers and CTs, as illustrated in Figure 9.5. If it becomes necessary or desirable to use the CTs on the transformer bushings, the normal differential connection cannot be used when the CTs are inside the delta, as in Figure 9.10. Two sets of CTs connected in parallel are required to provide protection for ground faults in these windings.

Star-connected CTs can be used on both sides. The phasor currents in Figure 9.10 show the balance for symmetrical currents flowing through the bank. There is a 2:1 ratio difference (per unit) of the CTs on the two sides. This can be adjusted by CT or relay taps, or a combination of both. Because each transformer is an individual unit, there will be no possibility of a phantom tertiary effect to plague the differential operation.

In case of three-phase banks, for which the three windings and interconnections are all inside the common tank, the standard differential connections as shown in Figure 9.5, Figure 9.6, Figure 9.8, or Figure 9.9 can be used with CTs located or with CTs in the three-phase transformer bushings on either side.

9.13 GROUND (ZERO-SEQUENCE) DIFFERENTIAL PROTECTION FOR TRANSFORMERS

The ground differential scheme provides compromise protection for delta–wye-grounded transformer banks. It is useful when there are no available or convenient CTs on the delta side. This is common for distribution and industrial ties with the delta as the high-voltage side and, possibly, protected by fuses.

This scheme protects only the wye-grounded windings and associated circuits, and is only for ground faults, the most likely and common fault. A typical application is shown in Figure 9.11 using a conventional differential relay. The differential zone includes the circuits between the two sets of CTs.

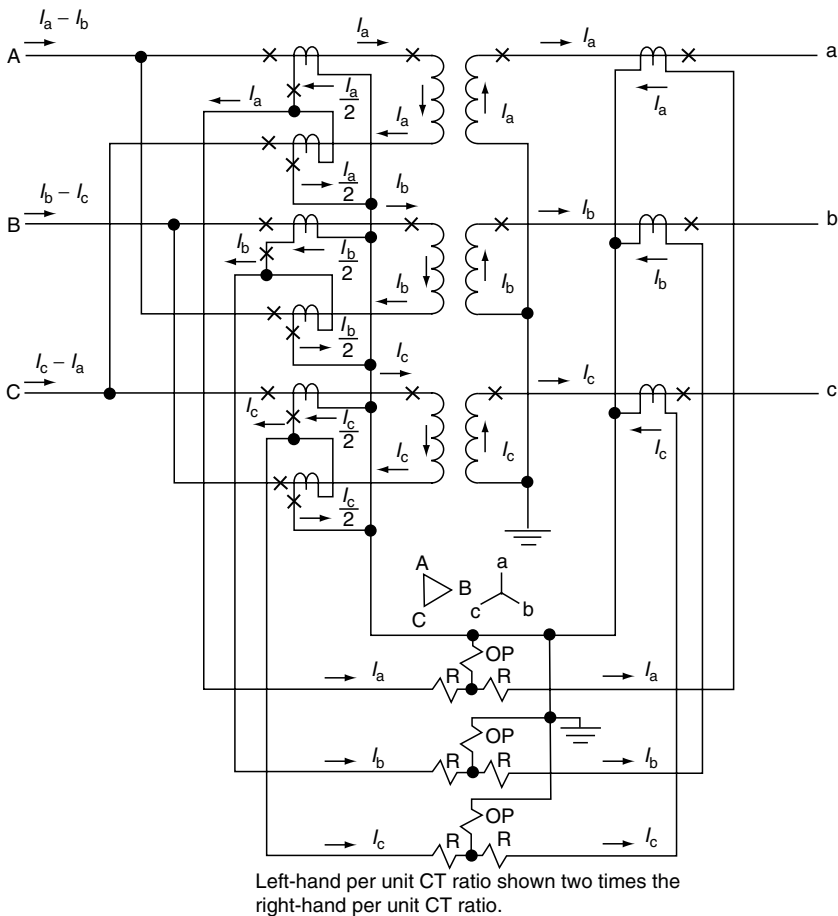
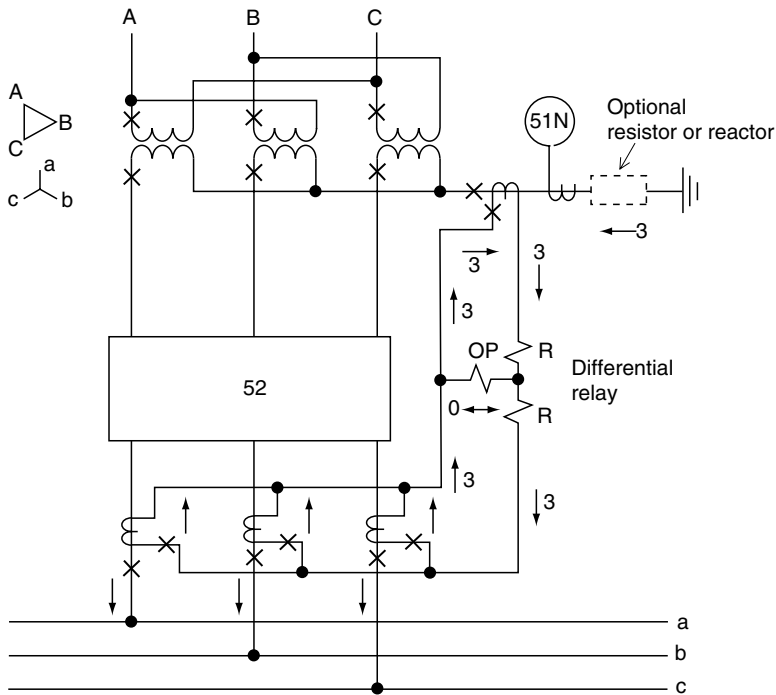

FIGURE 9.10 Differential relay connections for the protection of three single-phase transformers connected delta-wye using CTs in the transformer bushings.

The delta blocks operation for faults in that area. The techniques of phasing and ratiing are as outlined previously, except that one uses only zero-sequence current flow to an external fault. These currents are shown in [Figure 9.11](#). The time-overcurrent relay 51N, shown connected to a separate CT, is recommended for all grounded transformers. It is a “last resort” ground-fault protection and must be set to coordinate with relays that it overreaches. This is discussed in more detail later. It may be connected in the differential circuit, which adds burden to the differential circuit and can affect the operation.



Zero-sequence current flow for external ground fault.

FIGURE 9.11 Ground (zero-sequence) differential protection for delta-grounded-wye transformer bank using a conventional differential relay.

If the delta side is protected by fuses, ground faults in the differential zone may not provide sufficient current to clear the faults adequately from the delta-side source. As indicated previously, a 1 pu phase-to-ground fault on the wye side appears as a 0.577 pu phase-to-phase fault on the delta side (see also Figure 9.20). This adds to the difficulty of detection. Any fault limiting by neutral impedances or fault resistance further reduces the fault magnitudes. Thus, it frequently becomes impossible to clear ground faults by the high-side fuses. Accordingly, the ground differential is useful for the ground faults in its zone. The problem is to clear the fault from the delta-side source without a local breaker and the difficulty of reaching the station in time, if the nearest breaker is at a remote station.

9.14 EQUIPMENT FOR TRANSFER TRIP SYSTEMS

Without a fault-interrupting device available at the transformer primary terminals, there are several possibilities for tripping remote breakers as necessary steps to clear faults. All these methods are in practical use.

9.14.1 FAULT SWITCH

A spring-loaded fault switch is connected to the delta-supply side. The transformer protection relays operate to release the switch and thus fault the source system. Protective relays at the remote breakers sense this fault and operate to clear it, thereby removing the sources.

Most commonly, this is a single switch that applies a solid single-line-to-ground fault to operate the remote ground relays. Often, these remote relays can operate instantaneously to provide rapid isolation. There are a few installations of a three-phase-to-ground switch that apply a solid three-phase fault. The advantage is high redundancy; one or two switches can fail and yet result in clearing the fault. Also, normally, the phase and, with one ground switch failure, the ground relays at the remote locations can clear the fault. The disadvantage is higher cost, increased maintenance, and applying a higher-current three-phase fault on the system. This grounding-switch technique is quite practical and relatively simple. However, some shudder at the thought of placing any deliberate fault on the system.

A motor operated disconnect switch can be applied on the transformer high side in combination with a fault switch. Such application allows for the prompt restoration of the line that had been tripped upon initiation of the fault switch. Opening of the motor operated switch is initiated when the fault switch has closed and the associated transformer is deenergized. The related power system line can then be restored automatically or manually. Sufficient time must be allowed for the motor operated switch to be fully opened before the line is restored. The motor operated switch must be located on the line side of the fault switch.

9.14.2 COMMUNICATION CHANNEL

The transformer protective relays initiate a tripping signal that is transmitted over a transfer trip channel to operate remote breakers. This channel may be by power-line carrier (radio frequency over the power lines), audio tones over a telephone circuit or microwave channel, or a direct-wire fiber-optic pilot pair. High security is very important to avoid undesired trip operation from extraneous signals on the channel. This and the usually high cost are the major disadvantages. It is most important that these equipment transfer trip systems be carefully and thoroughly engineered. It is not possible to enhance their security with fault detectors at the breaker-tripping terminals, because the low-side faults generally will be at a low level, too. As in the case of a fault switch, a motor operated disconnect switch can be applied to isolate the transformer from the system subsequent to the operation of the transfer trip scheme. The communication channel used for transfer trip can also be used to supervise reenergization of the line to assure that the motor operated switch is fully open before the line is reestablished.

9.14.3 LIMITED FAULT-INTERRUPTION DEVICE

A circuit switcher or breaker with limited fault-interrupting capability is installed at the transformer on the delta-source side. The transformer protective relays initiate the tripping of this device directly or with a slight time delay. The scheme is based on the good probability that the remote relays will operate and clear any high-current fault at high speed and before the circuit switcher or breaker can open. If the remote relays do not sense the fault or if they operate slowly, the level of fault current is within the interrupting capabilities of the local devices. Fault detectors may also be applied to block operation of the limited fault-interruption device. Settings for the fault detector should be coordinated with the interrupting capability of the device.

9.15 MECHANICAL FAULT DETECTION FOR TRANSFORMERS

The accumulation of gas or changes in pressure inside the transformer tank are good indicators of internal trouble. These devices are recommended, wherever they can be applied, as excellent supplementary protection. They are frequently more sensitive, hence will operate on light internal faults that are not detected by differential or other relays. However, it is important to recognize that their operation is limited to problems inside the transformer tank. They will not operate for faults in the transformer bushings or the connections to the external CTs. Thus, their protective zone is only within the tank, in contrast with the differential protective zone given in [Figure 9.5](#).

9.15.1 GAS DETECTION

Gas detection devices can be applied only to transformer units built with conservator tanks. This type of transformer is common in Europe, but is not widely used in the United States. For these units with no gas space inside the transformer tank, a gas accumulator device commonly known as the Buchholz relay is connected between the main and the conservator tanks. It collects any gas rising through the oil. One part of the relay accumulates gas over a time to provide sensitive indication of low-energy arcs. It is used generally to set off alarm, as gas may be generated by tolerable operating conditions. The other part responds to heavy faults, forcing the relay to open at high velocity. This is used to trip in parallel with the other transformer protection.

9.15.2 SUDDEN PRESSURE

Sudden pressure devices are applicable to oil-immersed transformers. One type operates on sudden changes in the gas above the oil, another on sudden changes in the oil itself. Both have equalizing means for slow changes in pressure, which occur with loading and temperature changes. They are

sensitive to both low- and high-energy arcs within the transformer and have inverse-time characteristics: fast for heavy faults and slow for light faults. Generally, they are used to trip with the contacts in parallel to the differential and other relay trip contacts, although they can be used for initiating an alarm, if preferred. Incorrect operations of sudden pressure relays have been experienced on faults external to the transformer. This is the main reason that some users have been reluctant to connect sudden pressure relays to trip. False trips are usually associated with faults that result in high fault current through the transformer. Such faults can cause movement of materials within the transformer, which results in an operation of the sudden pressure relay. This is more likely to occur on older transformers in which the structural integrity of the bracings within the transformer has weakened over time. One strategy that can be used to address this problem is to supervise tripping by the sudden pressure relay with a fault detector relay. The fault detector relay blocks tripping by sudden pressure on heavy faults, which may result in false trips. Their ability to detect and isolate the transformer on low-level arcing faults before failure, preventing major internal damage, is a major benefit of applying sudden pressure relays.

9.16 GROUNDING TRANSFORMER PROTECTION

To provide system grounding on the delta side of power system transformer banks, a shunt-connected grounded wye–delta or zigzag transformer bank is applied. With wye–delta units, the delta operates as an unloaded tertiary to circulate zero-sequence current. If this tertiary has a CT available inside the delta, it can be connected to a time–overcurrent 51N relay. This relay receives I_0 for ground faults out on the system, so it must be coordinated with other ground relays.

The ground differential protection (see Figure 9.11) is applicable to the grounded wye–delta units, and as shown in Figure 9.12 for zigzag units. An alternative is to use three-phase time–overcurrent 51 relays, each connected to one of the line-side CTs. Because load does not pass through these units, the CT ratios and relay taps can be based on ground-fault current.

The zigzag bank essentially consists of three 1:1 ratio transformers that are interconnected (see Figure 9.12). The zero-sequence current flow is illustrated. Positive- and negative-sequence currents cannot flow, as they are 120° out of phase.

Sudden pressure- or gas-actuated trip relays are highly recommended wherever applicable for light internal fault protection. Turn-to-turn faults are always difficult to detect. In a zigzag unit, they can be limited by the magnetizing impedance of an unfaulted phase.

Grounding transformers are often directly connected to the bus or associated power transformer without a fault-interruption device. A typical example

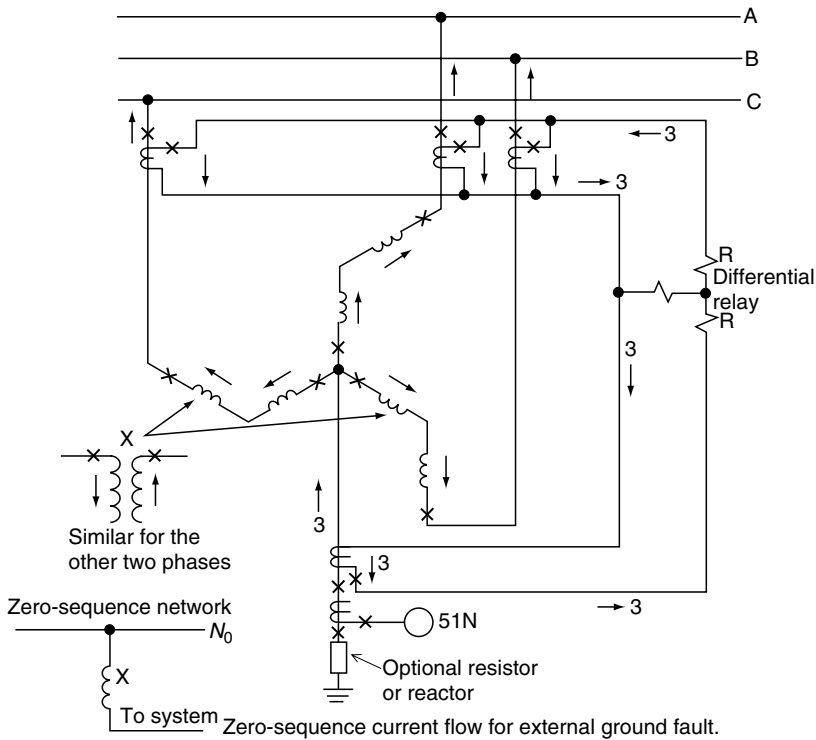

FIGURE 9.12 Ground (zero-sequence) differential protection for a zigzag transformer bank using a conventional differential relay.

would be to connect the grounding unit between the power transformer delta and the right-hand circuit breaker as in Figure 9.9. This application requires the use of a zero-sequence source at this point on both sides of the wye–delta bank, with a 30° shift to the bank.

With the grounding bank within the transformer differential zone, as indicated, an alternative connection to Figure 9.9 would be to connect the right-hand CTs in wye with a zero-sequence trap, and the left-hand CTs in delta.

A set of auxiliary CTs could be used instead of the zero-sequence trap to provide the necessary zero-sequence isolation and the 30° shift. The trap is preferred, because it is involved only during ground faults. Several arrangements are possible. In working these out, one should not connect the main CTs in wye and to the delta-connected auxiliary, because there could be no zero-sequence path for primary fault currents.

9.17 GROUND DIFFERENTIAL PROTECTION WITH DIRECTIONAL RELAYS

If the CT ratios or characteristics are not suitable for the application of conventional differential relays, a directional-overcurrent relay, differentially connected, can be used. This is particularly applicable in situations where ground-fault current is limited by neutral impedance or where a low neutral CT is used for higher sensitivity for remote faults on distribution feeders.

Two applications are shown. [Figure 9.13](#) and [Figure 9.14](#) use an auxiliary current-balancing autotransformer. [Figure 9.15](#) and [Figure 9.16](#) use an auxiliary 1:N transformer. One of the two diagrams shows the operation for external faults, the other for internal faults. The types are equivalent where $(1 - n)/n = N$.

Two types of relays can be used in either scheme, either solid-state or electromechanical product, or directional-overcurrent units. The electromechanical product relay is an induction-disk unit, in which the torque control or lag circuit is available as one circuit, and the main coil the other circuit. These relays have two inputs shown in the diagrams as two coils with (+) polarity markings. The operation is the product of the currents in the two circuits times the cosine of the angle between them. When currents in phase are flowing into the polarity marks ($\cos 0^\circ = 1$), the relay has maximum operating torque to close the contacts. If one current is in polarity in one coil and out of polarity on the other ($\cos 180^\circ = -1$), the relay has maximum nonoperating or restraint torque. Zero torque occurs when the two currents are $\pm 90^\circ$. This relay can operate with wide differences of current magnitudes as long as the product is greater than the pickup minimum, and with relative independence of the phase-angle variations within $\pm 90^\circ$. It has inverse-time characteristics, operating very fast for large-current internal faults.

The directional-overcurrent relay has a separate directional unit that operates as the product unit. The overcurrent unit of the relay is nondirectional and operates on the magnitude of current in its main coil. In the figures, it is indicated as the coil without polarity and connected basically across the CTs. Moreover, it has inverse-time characteristics, operating at higher speed for high current, but only if the directional unit has functioned. It is torque-controlled.

The auxiliary transformers are required to provide correct differential operation: not to operate for external faults outside the differential zone, but to operate for the ground faults inside the differential zone. These schemes operate when no ground current is supplied from the system to the internal faults. This would be common for many distribution and industrial applications. With no current, as in [Figure 9.14b](#) and [Figure 9.16b](#), it must be recognized that some of the neutral secondary current will be diverted to

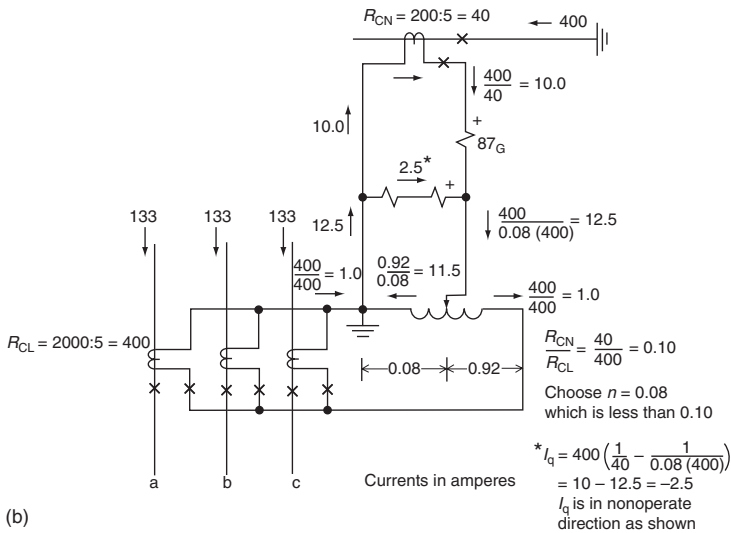
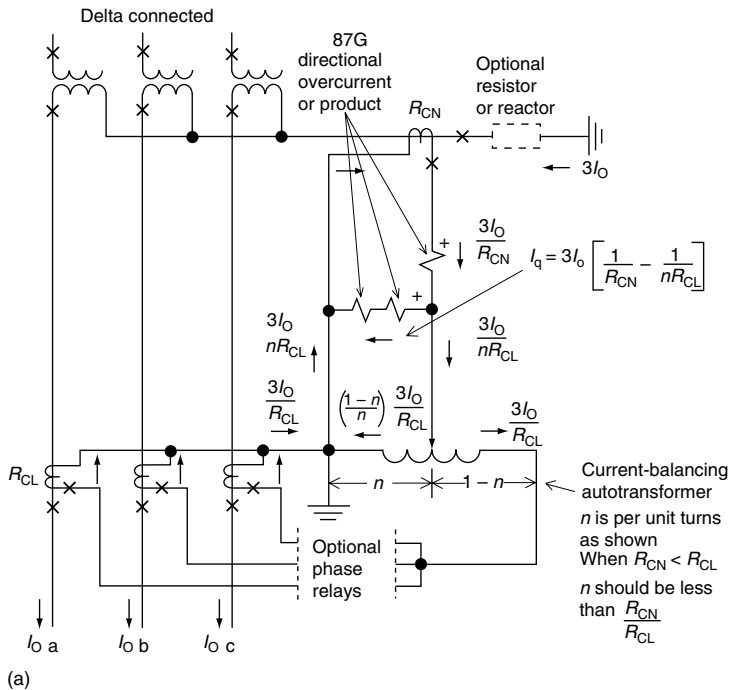

FIGURE 9.13 Ground (zero-sequence) differential protection for a delta-grounded—wye transformer bank using a direction overcurrent relay with current-balancing autotransformer. The currents shown are for external faults: (a) zero-sequence current flow for external ground faults; (b) example of zero-sequence current flow for an external ground fault (directional sensing relay does not operate).

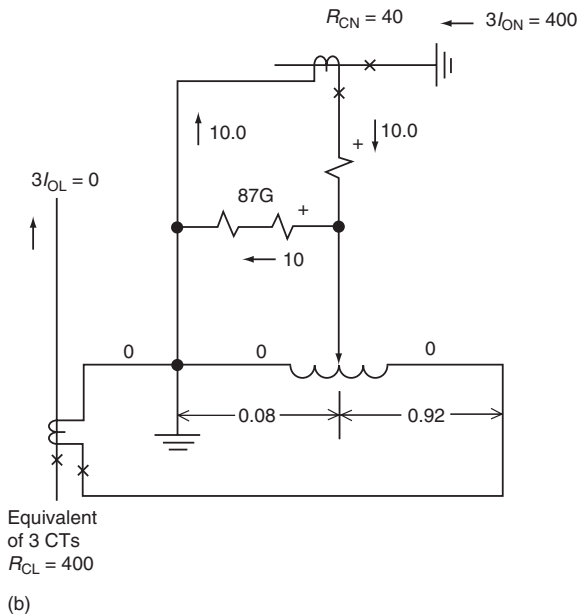
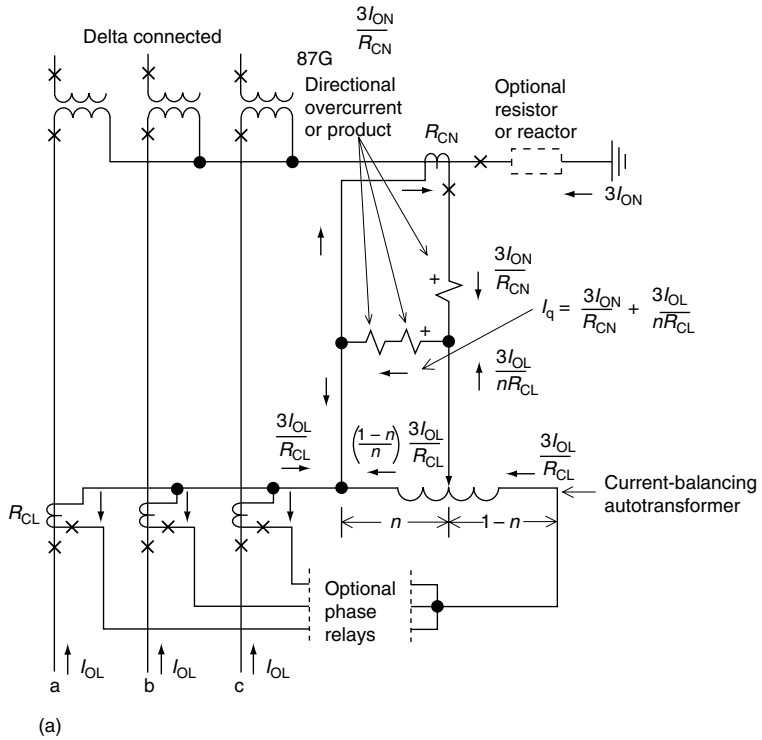

FIGURE 9.14 Operation of the differential system of Figure 9.13 for internal faults. (a) Zero-sequence current flow for internal ground faults; (b) example of zero-sequence current flow for an internal ground fault, with no current from line (currents in amperes).

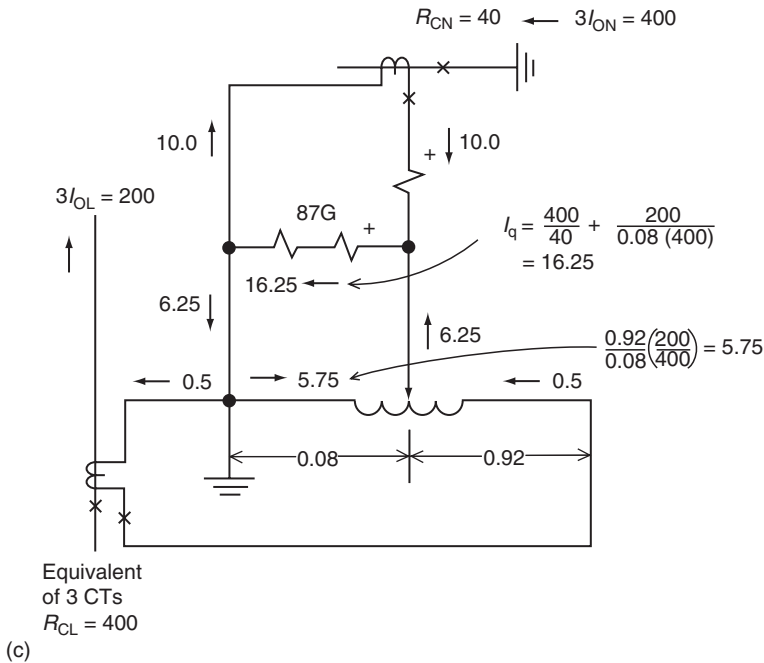

FIGURE 9.14 (continued) (c) Example of zero-sequence current flow for an internal ground fault, with current from line (currents in amperes).

excite the auxiliaries and line CTs, as discussed in [Chapter 5](#). This should be small with good-quality CTs and it is neglected in the figures.

If ground current is always supplied from the system for internal faults, the product relay could be applied with one coil connected across the line CTs and the other coil across the neutral CT without any auxiliaries. As indicated, it can operate with wide differences in currents and CT performances. The directional-overcurrent relay could be connected only to the line CTs, to operate for faults in the bank without any connection to the neutral CT. Often the latter connection would not be very sensitive, because the remote ground sources generally are quite weak.

9.18 PROTECTION OF REGULATING TRANSFORMERS

Regulating transformers are designed for specific problems involved in the interchange of power between two systems, in-phase for var control and phase-angle-type real power. Some include both in-phase and phase-angle controls. Their designs are complex and specialized for the specific application. The units generally have series and shunt or exciting windings.

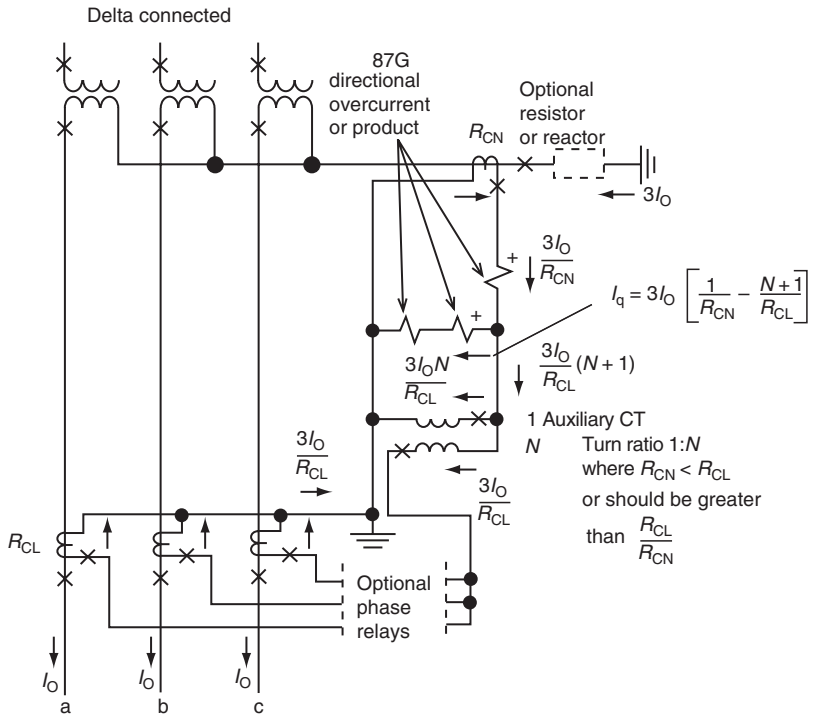

(a)

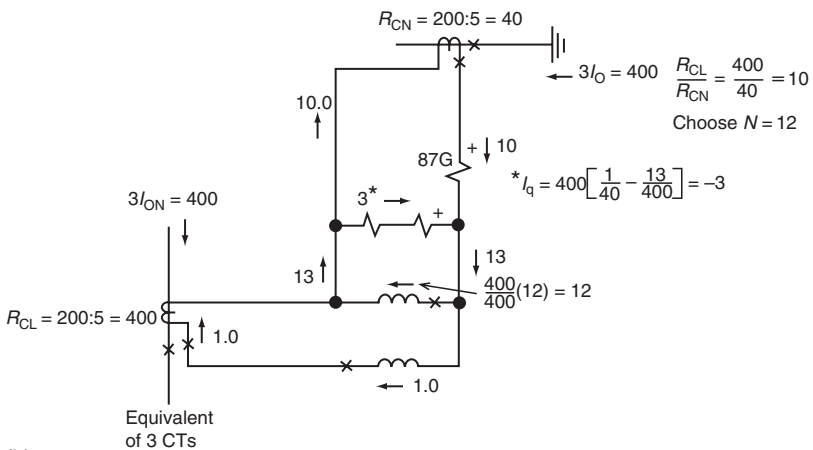

FIGURE 9.15 Ground (zero-sequence) differential protection for a delta-grounded-wye transformer bank using a directional-overcurrent relay with auxiliary CT (currents shown are for external faults). (a) Zero-sequence current flow for external ground fault. (b) Example of zero-sequence current flow for an external ground fault directional (currents in amperes).

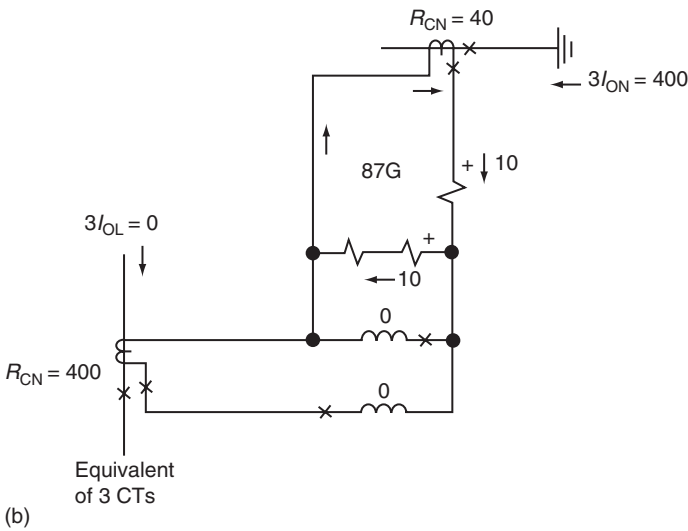
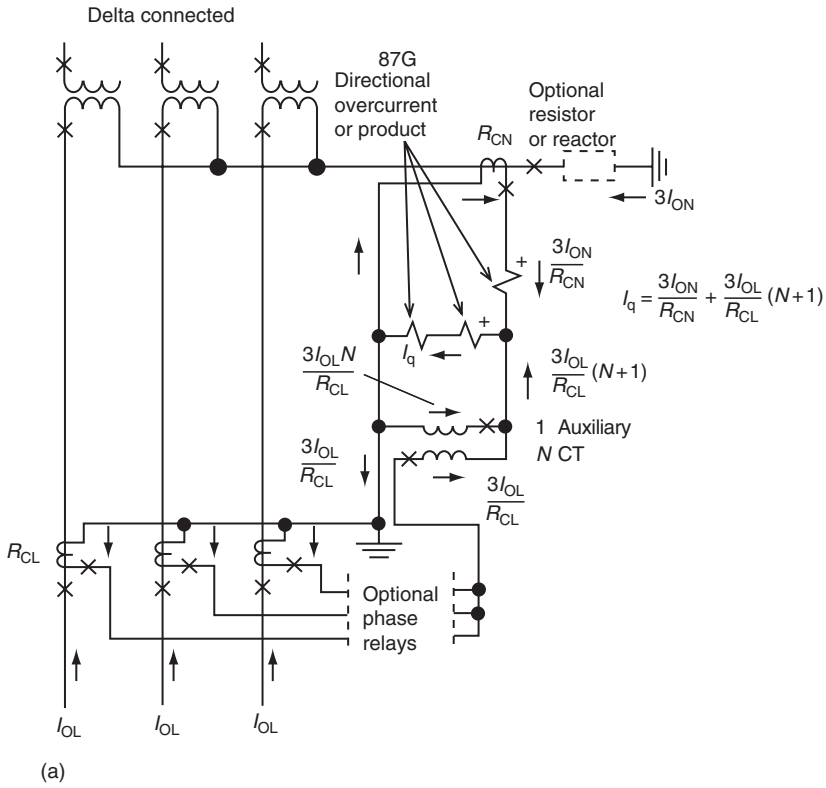

FIGURE 9.16 Operation of the differential system of Figure 9.15. (a) Zero-sequence current flow for internal ground faults. (b) Example of zero-sequence current flow for an internal ground fault, with no current from line (currents in amperes).

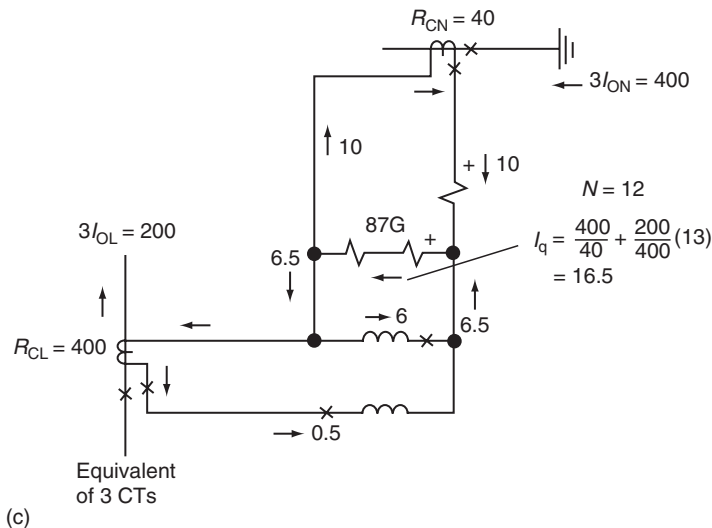

FIGURE 9.16 (continued) (c) Example of zero-sequence current flow for an internal ground fault with current from line (current in amperes).

Sudden or fault pressure relays provide good first-line protection. Differential protection is difficult and insensitive, particularly for faults in the exciting winding, and required current transformers within the unit, usually with overcurrent backup. Thus, the protection should be planned and worked out with the manufacturer.

9.19 TRANSFORMER OVERCURRENT PROTECTION

Phase- or ground-fault overcurrent protection is common for transformers. This is either as the primary protection for smaller units or for any unit without differential protection, or as backup protection on larger units protected by differential relays. For sizes of about 10 MVA and below, primary fuses may be used. Otherwise, inverse-time-overcurrent relays and, at higher voltages, distance relays provide protection for the transformer and associated circuits. Because these devices can operate well outside the transformer protection zone, their application and setting are a combination of transformer and associated system protection. The emphasis here is on transformer protection and the subject is expanded later in connection with the protection of other equipment, primarily on feeder and line protection.

It is desirable to set the protective devices as sensitive as possible, but the fuses and phase-overcurrent relays must not operate on any tolerable condition, such as magnetizing inrush; the maximum short-time overloads, such as

one that may occur when reenergizing circuits after an outage (cold-load pickup); or any emergency-operating condition. The ground relays must be set above the maximum zero-sequence unbalance that can exist chiefly as the result of single-phase loading.

Instantaneous overcurrent relays must be applied to supplement differential or overcurrent protection and provide protection for heavy primary transformer faults. They must be set in such a manner that they do not operate on magnetizing inrush (unless a harmonic restraint is used), on the maximum short-time load (cold-load), or on the maximum secondary three-phase fault. A typical setting would be 150%–200% of the greatest of these currents. This may limit their operation on primary faults.

On the other hand, the relays or fuses should protect the transformers against damage from through faults. High fault current passing through the transformer can cause thermal as well as mechanical damage. High temperatures can accelerate insulation deterioration. Their physical forces from high currents can cause insulation compression, insulation water, and friction-induced displacement in the windings. ANSI/IEEE defines the limits for these faults.

9.20 TRANSFORMER OVERLOAD-THROUGH-FAULT-WITHSTAND STANDARDS

The ANSI/IEEE standards for distribution and power transformers specifying their overload-through-fault capabilities were changed around the year 1977 (see IEEE C57.12 and the article by Griffin in the Bibliography). Comparison of the change is given in [Table 9.1](#). The multiples of rated current represent the maximum possible and are derived assuming an infinite source (zero impedance). Thus, the maximum symmetrical fault through the transformer bank with 4% impedance would be $1/0.04 = 25$ pu or 25 times the bank-rated current, as shown.

The source impedance is never zero, but it can be very small relative to the transformer bank impedance, particularly for an industrial plant or small distribution substation that is connected to a large utility power system. Hence, the multiples represent a maximum limit.

Soon after this change to all 2-s limits, protection engineers discovered that they had been using a thermal overload curve ([Figure 9.17a](#)), published in ANSI Standard C37.91, *Guide for Protective Relay Applications to Power Transformers*, for overcurrent transformer protection, and that the new 2-s standard would severely limit power transformer protection for through faults. This dilemma has led to further changes, which were approved in late 1982 and are summarized in [Table 9.2](#) and [Figure 9.17](#). These changes are incorporated in the several applicable standards. The conflict existed because C37.91 was a thermal damage curve, whereas C57.12.00 was concerned

TABLE 9.1
ANSI/IEEE Transformer Overcurrent Capability Standards Until
Modified in 1982^a

Multiples of Rated Current		Maximum Current Withstand (sec)	
		1977 (1980)	(1973)
25	4	2	2
20	5	2	3
16	6	2	4
14 or less	8 or greater	2	5

^aANSI/IEEE C57.12.00. Old standard dated 1973, approved 1977, but not officially published until 1980.

TABLE 9.2
ANSI/IEEE Transformer Overload-Through-Fault Standard Categories

Category	Transformer Ratings (kVA)		Use Curve (Fig. 9.17)	Frequent Faults ^a	Dotted Curves Apply from ^b
	Single-Phase	Three-Phase			
I	5–500	15–500	a	—	25–501, where $t = \frac{1250f}{60I^2} = \frac{1250}{I^2}$ at 60 Hz
II	501–1,667	501–5,000	a or a + b	10	70%–100% of maximum possible fault where $I^2t = K$; K is determined at maximum I , where $t = 2$
III	1,668–10,000	5,001–30,000	a or a + c	5	50%–100% of maximum possible fault where $I^2t = K$; K is determined at maximum I , where $t = 2$
IV	Above 10 MVA	Above 30 MVA	a + c	—	Same as category III

^aFaults that occur frequently are typically more than the number shown and are for the lifetime of the transformer. Infrequent faults are less than that shown for the life of the transformer. Category II and III frequent-fault curve (see Figure 9.17a) may be used for backup protection when the transformer is exposed to frequent faults, but is protected by high-speed primary relays.

^b I , symmetrical short-circuit current in per unit of normal base current using minimum nameplate kVA; t , time in seconds; f , frequency in hertz. Per-unit currents of 3.5 or less probably result from overloads, in which case the transformer-loading guides should be followed.

primarily with mechanical damage from the through faults. The latest changes (see Figure 9.17) cover both thermal and mechanical limits.

The new standard has six curves, one each for categories I and IV, and two each for categories II and III. The basic curve shown by the solid line in Figure 9.17 for all categories is the same and, as such, applies to all 4% impedance transformers. These can withstand through currents that are 25 times normal base current for 2 seconds. Modifying curves (shown as dashed lines) apply to transformers with other than 4% impedance, depending on the fault frequency over the entire life of the unit.

The frequency of faults that might occur during the entire life of a transformer is an estimation based on experience and judgment. A guide to aid in this determination is outlined in Figure 9.18. In cases of doubt, the frequent-fault curves should be used.

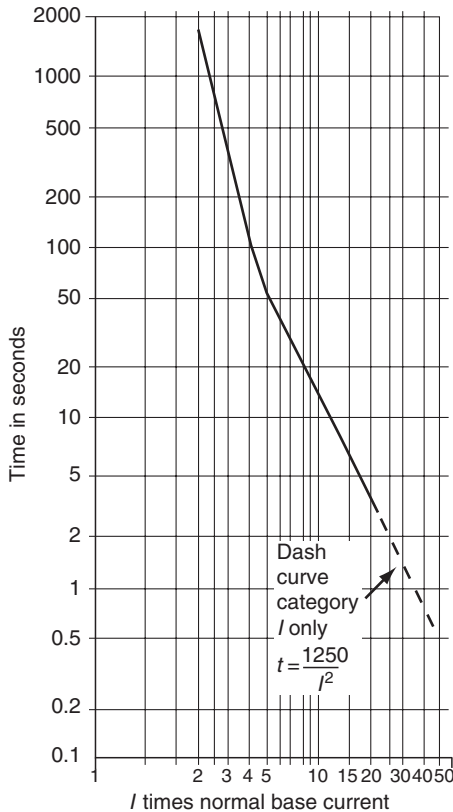

(a)

FIGURE 9.17 Through-fault protection curves for transformers: (a) For category I frequent or infrequent faults and for infrequent faults with categories II and III.

Use category I curve above 50 sec

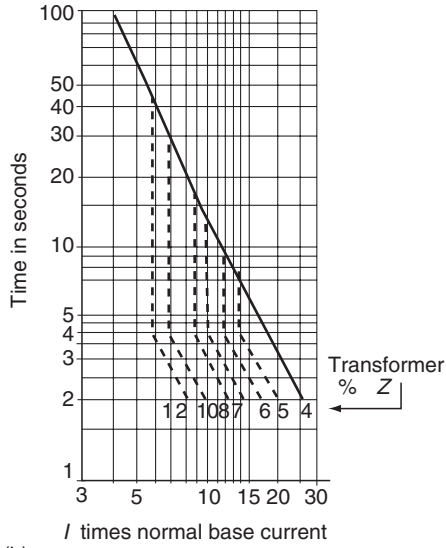

(b)

Use category I curve above 100 sec

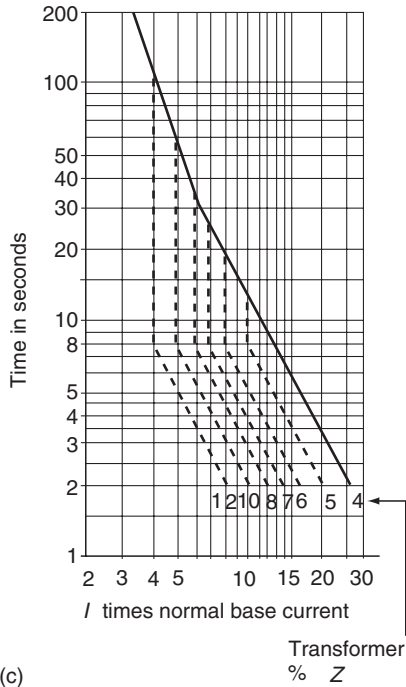

(c)

FIGURE 9.17 (continued) (b) For frequent faults with category II transformers. (c) For frequent-fault category III and frequent or infrequent category IV transformers.

The application of transformer protection to meet this standard can be outlined as follows: For a given transformer

1. Determine the category from [Table 9.2](#)
2. If in category II or III, determine whether the service is subject to frequent or infrequent faults (see [Figure 9.18](#))
3. Select the appropriate curve from [Figure 9.17](#) (or the ANSI standard)
4. Replot the curve on suitable log–log paper using amperes related to the specific transformer (per unit could be used, but because relays and fuses operate on current, amperes is preferable). Either system-primary or system-secondary current can be used, properly translated as required through the transformer bank. Generally, secondary-side currents are preferred for coordinating with other secondary downstream devices

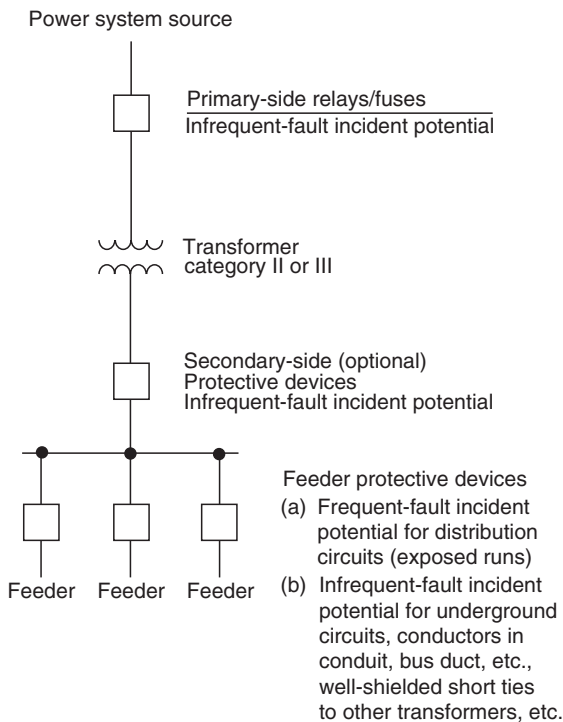

The primary protection zone for each of the protection devices is between that device and the next downstream device.

FIGURE 9.18 Suggested guide for determining zones of infrequent and frequent incident potential.

5. Select proper fuses or relays with tap, time dials, and so on, to protect the transformer and coordinate with all other devices in the area

The details of this are best illustrated by examples.

9.21 EXAMPLES: TRANSFORMER OVERCURRENT PROTECTION

The several examples are from IEEE C37.91, *Guide for Protective Relay Applications to Power Transformers*. These appear as typical applications.

9.21.1 AN INDUSTRIAL PLANT OR SIMILAR FACILITY SERVED BY A 2500 kVA, 12 kV: 480 V TRANSFORMER WITH 5.75% IMPEDANCE

The protection consists of power fuses on the primary and low-voltage direct-acting circuit breakers with series overcurrent trip units on the secondary side and associated feeders. From Table 9.2, this transformer is category II, and with metal-clad or metal-enclosed secondary switchgear, the fault frequency can be considered infrequent. Thus, Figure 9.17a is applicable.

This curve is replotted on Figure 9.19, where the abscissa is secondary amperes. This translation is

$$I_{\text{per unit}} = I_{\text{rated}} = \frac{250}{\sqrt{3} \times 0.48} = 3007 \text{ A at } 480 \text{ V} \quad (9.19)$$

and so for various times:

For 50 sec and less,

$$T = \frac{1250}{I^2} \quad \text{such as} \quad \frac{1250}{5^2} = 50 \text{ sec}, \quad (9.20)$$

as shown. The maximum possible current with an infinite source is

Time (sec) from Figure 9.17a	Per Unit/from Figure 9.17a	Equivalent/Amperes at 480 V (pu × 30,007)
1,000	2.3	6,916
300	3.0	9,021
100	4.0	12,028
50	5.0	15,035
12.5	10.0	30,070
4.13	17.39	52,296

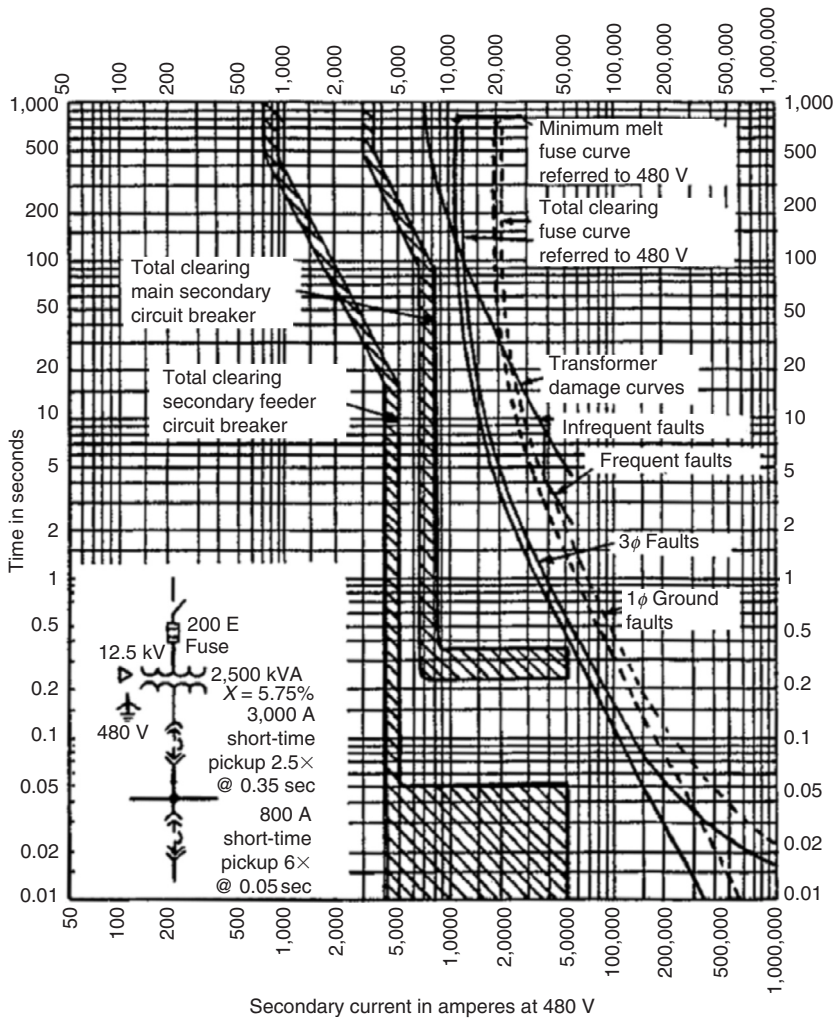

FIGURE 9.19 Overcurrent protection for a category II transformer serving an infrequent-fault secondary system.

$$I = \frac{1}{0.0575} = 17.39 \text{ pu}, \tag{9.21}$$

where

$$t = \frac{1250}{17.39^2} = 4.13 \text{ sec}, \tag{9.22}$$

so this is the termination of the transformer through-fault protection curve.
On the primary side, rated current is

$$I_{\text{per unit}} = I_{\text{rated}} = \frac{2500}{\sqrt{3} \times 12} = 120.3 \text{ A at 12 kV.} \quad (9.23)$$

To avoid operation on magnetizing inrush, short-time transient load, and so on, and yet provide protection for secondary faults, typical fuse ratings are selected at about 150% of rated current. Thus $1.5 \times 120.3 = 180.4$ A, therefore, 200 A fuses were selected and their time characteristics plotted. Both total clearing and minimum melt curves are shown. As the current magnitude in the primary is only 57.7% of the secondary current for phase-to-ground faults, the fuse curves are moved to the right by multiplying all values by 1.73 ($\sqrt{3}$) in addition to the transformer-winding ratio (see Figure 9.19). The three-phase fault magnitudes are the same in per unit (Figure 9.20). The fuse curves extend to higher currents, as these are possible for high-side faults (in primary amperes) between the fuses and the transformer.

The transformer secondary and the feeders have low-voltage circuit breakers with direct-acting overcurrent units. These have long-time and short-time instantaneous elements. The characteristics are a band between the total clearing times and the reset times (see Figure 9.19). For this example, the transformer breaker long-time unit is set to pick up at $1.2 I_{\text{rated}} = 1.2 \times 3007 = 3608$ A at 480 V, where the time is 450 sec. The short-time pickup is set at $2.5 I_{\text{rated}}$, or $2.5 \times 3007 = 7518$ A at 480 V. A time delay of 0.35 sec is used to provide coordination with the feeders. The feeder circuit breakers are set with the long-time unit at $1.2 \times I_{\text{rated}} = 1.2 \times 800 = 960$ A and the short-time set instantaneously (0.05 sec) at 6 times 800, or 4800 A at 480 V. Chapter 12 gives more details on these setting criteria.

The protection plot of Figure 9.19 shows good protection and coordination except for light secondary faults. The primary fuse curves cross the transformer through the fault protection curve at about 13,000 A for the three-phase faults at about 23,000 A for phase-to-ground faults. This indicates that the transformer is not protected according to the standard for faults of these magnitudes—or less—by the fuses. Such faults are possible. If they are in the transformer, damage has already occurred and would become heavier before the source can be removed by the fuses. If they are between the transformer and the secondary circuit breaker, it must also develop to a heavier fault, which means more damage and time; however, the probability of faults in this area will usually be small.

Typical industry data indicate that, at 480 V, arcing phase-to-ground faults may be as low as 19% of the rated fault value. Thus, for a secondary fault maximum of 52,296 A, the primary current for the fuses would be $52,296 \times 0.19 \times 0.577 \times 0.48/12 = 229$ A kV, just above the 200 A rating,

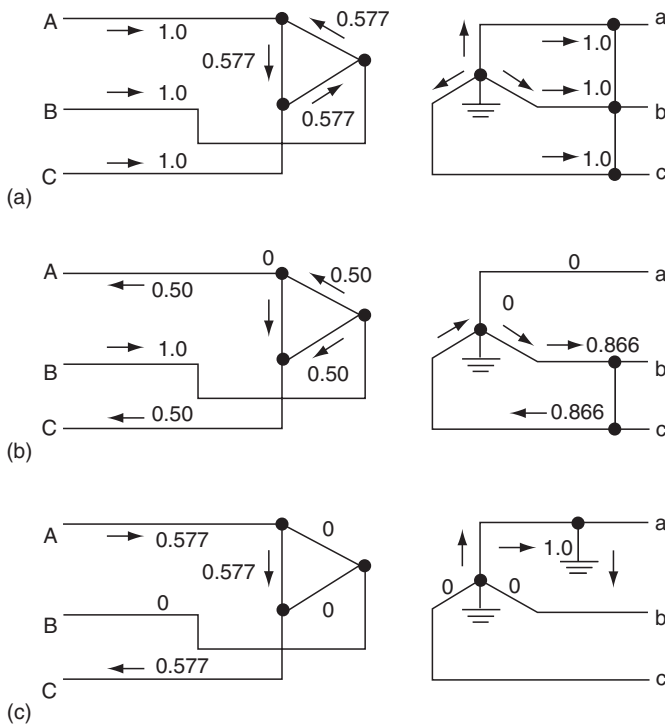

FIGURE 9.20 Review of faults through delta–wye transformer banks (currents shown in per unit): (a) three-phase faults; (b) phase-to-phase faults; (c) phase-to-ground faults, where $X_1 = X_2 = X_0$.

and it is doubtful that the fuses will give any protection until severe burning increases the fault current.

Secondary faults on the bus should be cleared by the secondary transformer circuit breaker and faults on the feeders by their circuit breakers backed up by the transformer breaker. Thus, the primary fuses are backup for faults if they can “see” these secondary faults.

The frequent-fault curve modification from [Figure 9.17b](#) has been shown in [Figure 9.19](#) for comparison. As can be observed, the primary fuse protection for through faults or secondary phase-to-ground faults is very marginal.

9.21.2 A DISTRIBUTION OR SIMILAR FACILITY SERVED BY A 7500 kVA, 115: 12 kV TRANSFORMER WITH 7.8% IMPEDANCE

The primary protection is power fuses. A transformer secondary breaker is not used, and the feeders have circuit reclosers.

This transformer is of category III and the secondary is subject to frequent faults. Similar to the example in [Section 9.21.1](#), the transformer through-fault

protection curve is translated from Figure 9.17a and Figure 9.17c to secondary amperes for Figure 9.21.

$$I_{\text{per unit}} = I_{\text{rated}} = \frac{7500}{\sqrt{3} \times 12} = 360.84 \text{ A at 12 kV.} \quad (9.24)$$

The maximum secondary fault, assuming that the source is very large relative to the transformer, and thus is infinite ($X = 0$), is

$$I_{3\phi} = I_{\phi G} = \frac{1}{0.078} = 12.82 \text{ pu} = 4626 \text{ A at 12 kV.} \quad (9.25)$$

Points on the transformer through-protection curve are:

Time (sec) from Figure 9.17a and Figure 9.17c	Per Unit/from Figure 9.17a, and Figure 9.17c	Equivalent/Amperes at 12 kV (pu \times 360.84)
1000	2.3	830
300	3.0	1082.5
100	4.0	1443.4
50	5.0 ^a	1804.2
30.42	6.41 ^b	2313
8	6.41 ^b	2313
3.29	10 ^b	3608.4
2	12.82 ^b	4626

^aFor infrequent-fault incident, $K = 1250$ from 5.0 to 12.82 pu; for frequent-fault incident, $K = 1250$ from 5.0 to 6.41 pu.
^bFor frequent fault incident, $K = 328.73$ from 6.41 to 12.82 pu.

On the primary side,

$$I_{\text{per unit}} = I_{\text{rated}} = \frac{7500}{\sqrt{3} \times 115} = 37.65 \text{ A at 115 kV} \quad (9.26)$$

and 65E-A fuses were used (1.73×37.65). Their characteristics are plotted in terms of secondary-side amperes for three-phase faults and secondary-side phase-to-ground faults.

The two feeder circuits are rated 280 A, and automatic circuit reclosers are applied with a 560 A minimum setting. Their characteristic curves for fast and slow operations are shown in Figure 9.21.

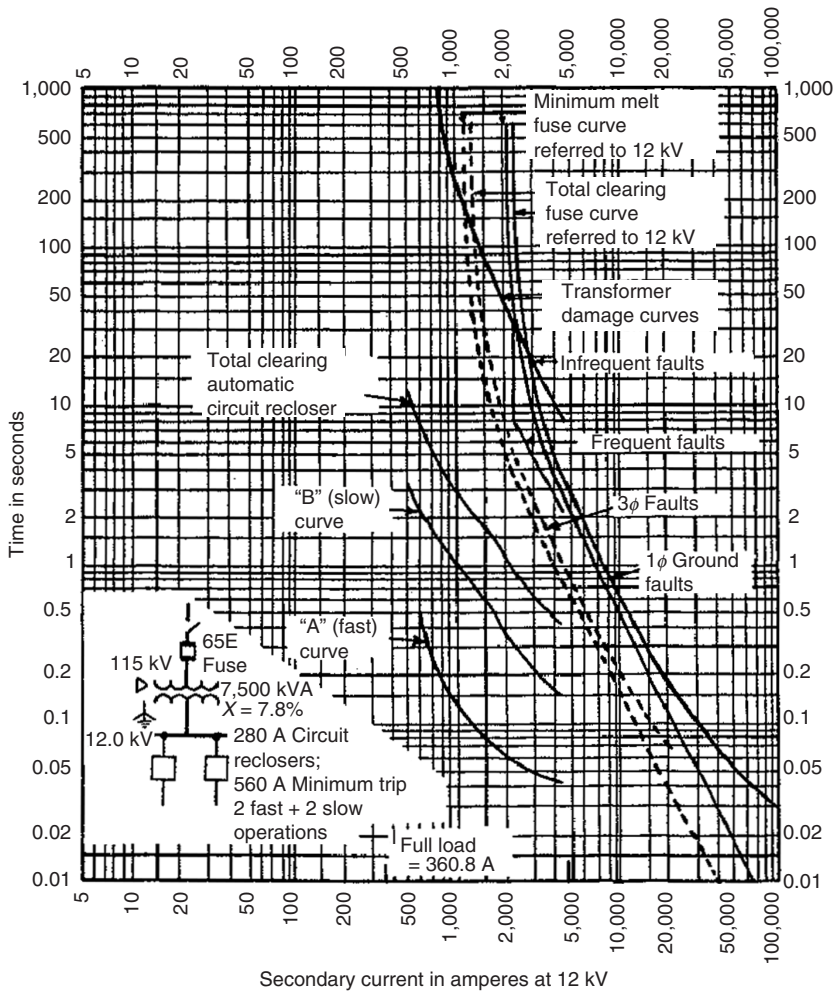

FIGURE 9.21 Overcurrent protection for a category III transformer serving a frequent-fault secondary system. Bank has primary fuses.

Although there is good coordination between the primary fuses and secondary circuit reclosers, the transformer is not protected for secondary phase-to-ground faults with the frequent-fault curve. In addition, with the infrequent-fault curve, there is inadequate protection for ground faults of about 3000 A and less. Moreover, the phase shift through the bank provides 57.7% less ground-fault current (see Figure 9.20).

For faults out on the feeders, the primary-side fuses serve as backup, therefore, they should seldom be called on to operate. However, the fuses are

primary protection for faults on the secondary side, up to the circuit reclosers. It is hoped that these ground faults will be infrequent and greater than 3000 A to avoid potential damage to the transformer. These are risks that must be evaluated by the power system personnel.

9.21.3 A SUBSTATION SERVED BY A 12/16/20 MVA, 115: 12.5 kV TRANSFORMER WITH 10% IMPEDANCE

The primary has a relayed breaker, but without a transformer secondary breaker. This is category III transformer, so that the curves at Figure 9.17a and Figure 9.17c can be applied, which are replotted on Figure 9.22, using secondary amperes. The maximum fault current with an infinite source ($X = 0$) is

$$I_{3\phi} = I_{OG} = \frac{1.0}{0.1} = 10 \text{ pu} = 5542.6 \text{ A at } 12.5 \text{ kV}, \quad (9.27)$$

where

$$I_{\text{per unit}} = I_{\text{rated}} = \frac{12,000}{\sqrt{3} \times 12.5} = 554.62 \text{ A at } 12.5 \text{ kV}. \quad (9.28)$$

K in Table 9.2 is 1250 for infrequent faults from 5.0 pu to the maximum of 10 pu, and $K = 200$ for infrequent faults over the same range.

The transformer has three MVA ratings: the first is a self-cooled rating, the second a rating with forced oil, and the third a rating with both forced oil and air. Thus, the maximum load is

$$\frac{20,000}{\sqrt{3} \times 115} = 100.4 \text{ A at } 115 \text{ kV} \quad (9.29)$$

and 100:5 (20:1) primary CTs are selected. Inverse-time–overcurrent phase relays (51) are set on tap 8, so pickup on $8 \times 20 = 160$ primary amperes, equivalent to 1472 A secondary amperes. Their pickup for secondary phase-to-ground faults is $1472/0.577 = 2551$ A. The relay-operating curves are plotted on Figure 9.22 for specified time dials.

The 12.5 kV feeders are 6000 kVA with 300:5 (60:1) CTs, relay pickup phase 480 secondary amperes (51), 240 secondary amperes ground (51G). These curves are plotted in Figure 9.22 for specified time dials.

This transformer bank is protected for through-three-phase secondary faults, but not for secondary phase-to-ground faults. In this application, differential protection should be applied and connected around the bank and secondary bus together with gas or pressure relays for primary protection. Only then, this service might be considered as infrequent service and the overcurrent primary relays provide reasonable backup protection.

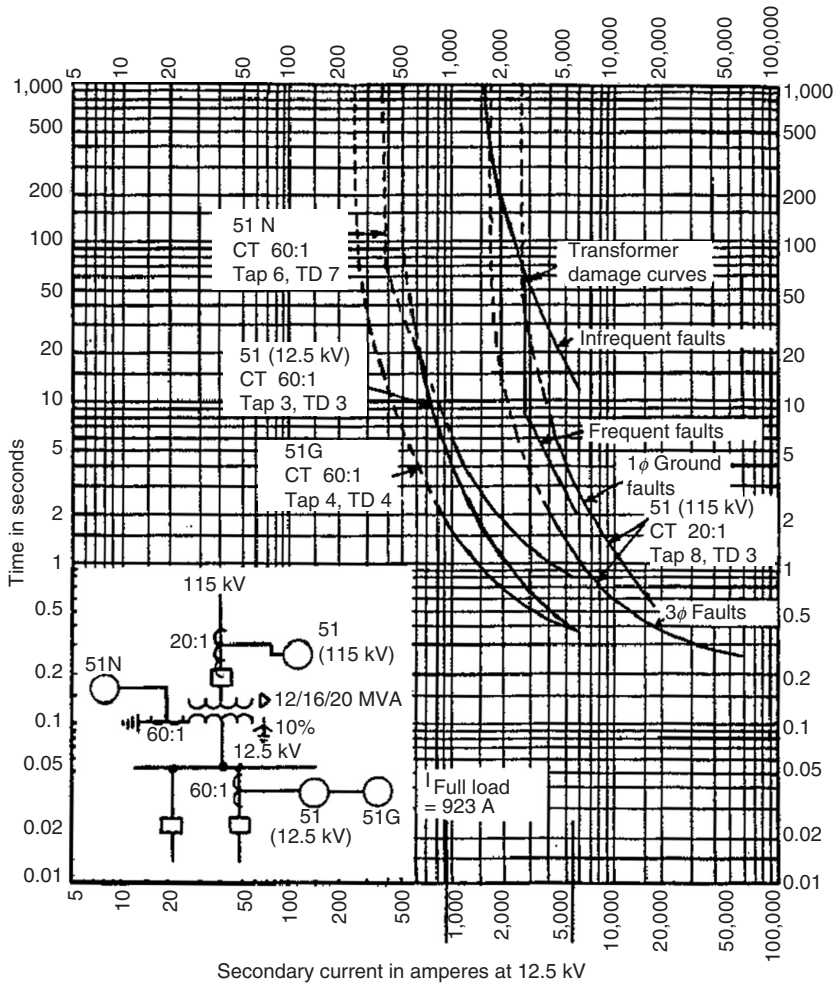

FIGURE 9.22 Overcurrent protection for a category III transformer serving a frequent-fault secondary system with primary circuit breaker and relays.

9.22 TRANSFORMER THERMAL PROTECTION

Thermal protection is usually supplied as a part of the transformer. Generally, it is used for monitoring and initiating an alarm, but may be used for tripping. Transformers can become overheated when overloaded beyond design limits. Such overloads are likely to occur when the system is highly loaded or during emergency-operating conditions. When thermal devices operate under such conditions, it is felt best to alert operators to the condition so that remedial actions can be initiated. Tripping under such conditions is not recommended

as immediate damage to the transformer is unlikely and removing a transformer from service when the power system is under stress can lead to more severe operating problems. Tripping is sometimes incorporated into the thermal protection scheme when a malfunction in the transformer cooling system (i.e., fan or pump failure) is detected in conjunction with the operation of thermal devices.

Various types of thermal indicators are used to detect overheating of the oil, tank, tank terminals, failures of the cooling system if used, hot spots, and so on. These devices may initiate forced-cooling equipment. This protection is beyond the scope of this book.

9.23 OVERVOLTAGE ON TRANSFORMERS

Transformers must not be subject to prolonged overvoltage. For maximum efficiency they are operated near the knee of their saturation curve, so at voltages above the 110% of rated, the exciting current becomes very high. Just a few percent increase in voltage results in a very large increase in current. These large currents can destroy the unit if they are not reduced promptly. Damage due to overvoltage is of special concern for transformers connected to high-voltage systems on which voltages cannot be always reliably controlled by regulating and control devices and for generator unit transformers. Overvoltage protection can best be provided by relays that respond to transformer excitation levels. Overexcitation protection is discussed in [Section 9.3.2](#). Overvoltage protection for generator unit transformers is discussed in [Chapter 8](#).

Protection against overvoltage is generally not applied on transformers connected to power systems on which voltage levels can be reliably controlled by voltage regulating devices as the probability for overvoltage conditions occurring on such systems is very low.

9.24 SUMMARY: TYPICAL PROTECTION FOR TRANSFORMERS

The protection that is recommended and commonly applied for transformers is summarized in the following figures. The application for the various devices has been discussed in previous sections. It should be noted and recognized that these are general recommendations. More or less protection may be applied for any specific situation and will depend on local circumstances and individual preferences.

9.24.1 INDIVIDUAL TRANSFORMER UNITS

[Figure 9.23](#) summarizes the protection for banks where fuses are used on the primary. For larger or important banks in this category, an overall differential

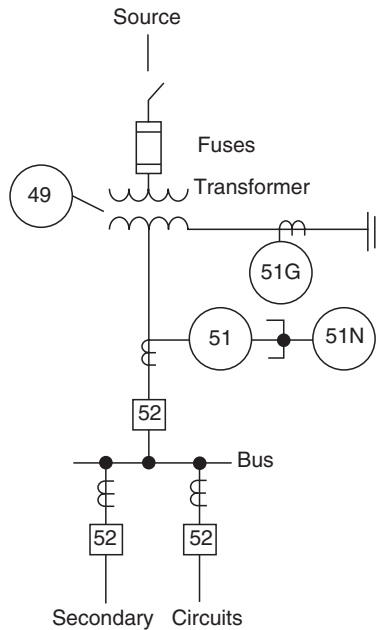

FIGURE 9.23 Transformer protection without primary-side circuit breaker. Common connection shown with delta on the source (primary) side and wye-grounded on secondary side. Other possible connections: delta–delta, wye–wye, or primary-wye–secondary-delta. Secondary circuits should have 51 and 51N relays; therefore, transformer secondary breaker and relays may be omitted unless another source connects to the secondary bus. 51N relay can be omitted with 51G available.

protection may be applied by using CTs in the transformer primary bushings, or a ground differential, as discussed in [Section 9.13](#). Both require primary source tripping as discussed in [Section 9.14](#).

For transformer banks with primary breakers, the protection is summarized in [Figure 9.24](#). Relay 51G provides backup protection for secondary bus and feeder faults and must be time-coordinated, with other ground relays protecting the various feeder circuits on the secondary bus. Similarly, phase relays 51 must be coordinated with the phase relays on the feeders. Relay 51G is set with a longer time and to coordinate with 51G.

9.24.2 PARALLEL TRANSFORMER UNITS

The protection for transformer banks where the secondaries are connected together by a bus tie breaker is summarized in [Figure 9.25](#). The arrangement shown is typical for large- or critical-load substations, especially for industrial plants. The loads are supplied from separate buses that are connected together by a bus tiebreaker (52T) that may be operated either normally closed (NC) or

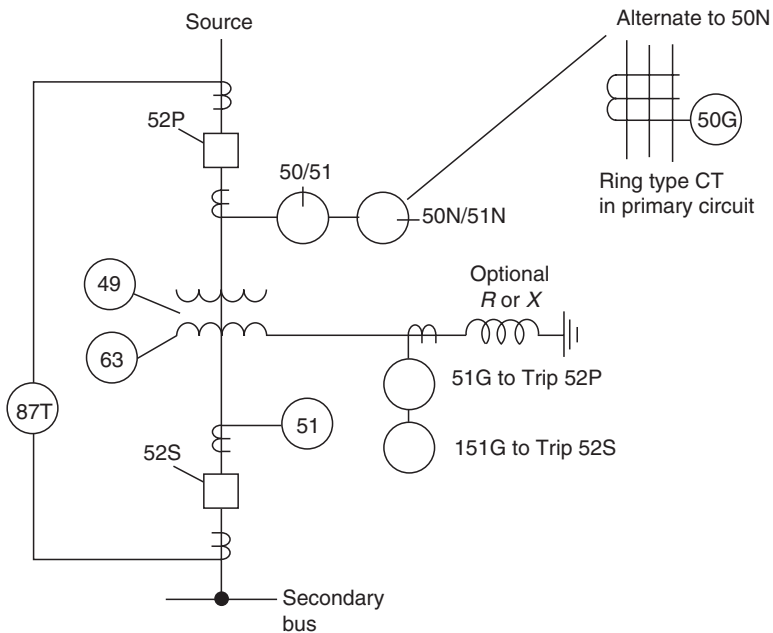
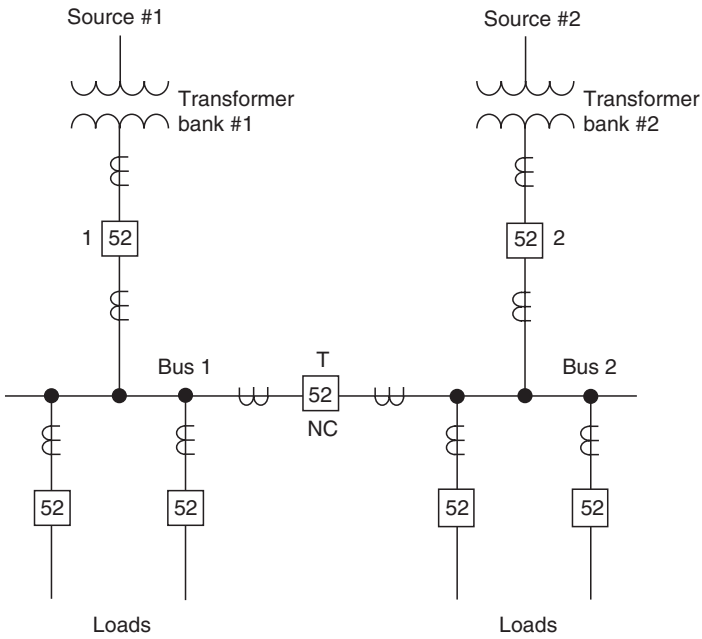

FIGURE 9.24 Transformer protection with primary-side circuit breaker: Common connection shown with delta on the source (primary) side and wye-grounded on the secondary side. Other possible connections: delta–delta, wye–wye, primary–wye–secondary–delta, three-winding, or autotransformer. 52S may be omitted in some applications requiring 151G to coordinate with and trip the secondary circuit devices, if used.

normally open (NO). If operated NO, the protection of [Figure 9.23](#) or [Figure 9.24](#) is applicable.

If operated with 52T NC, the protection of [Figure 9.23](#) and [Figure 9.24](#) is applicable with the secondary side modified (see [Figure 9.25b](#) or [c](#)).

With the bus tiebreaker closed, there is a possibility for the interchange of power between the two sources. Here, current flows from one source through its transformer, the secondary buses, and back through the other transformer to the second source. Generally, this is neither desirable nor permitted. To prevent this operation, directional time–overcurrent relays (67, 67N) are applied to each transformer. The single-line connections are shown in [Figure 9.25b](#) and [Figure 9.25c](#), with complete three-line connections in [Figure 9.26](#). They operate only for fault current that flows into the transformer and trip the secondary breaker (52–1 or 52–2). This is also important in removing a secondary fault source for faults in the transformer bank. The phase relays (67) can be set on a low of minimum tap. Load current certainly flows through the relay, but normally not in the operating direction. The low tap continuous rating must not be exceeded



(a)

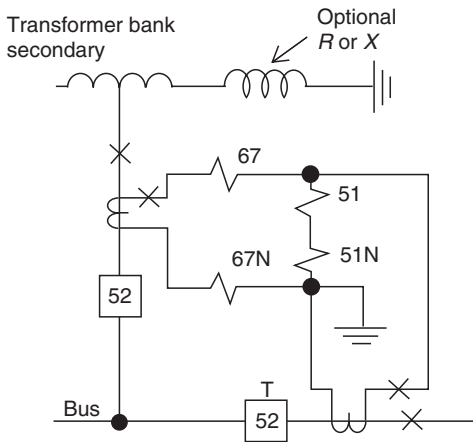

(b)

FIGURE 9.25 Transformer and secondary bus protection for a typical double-source supply with secondary tie and breaker. For 67 and 51 connections, see [Figure 9.26](#). For 87G connections, see [Figure 9.13](#) through [Figure 9.16](#). (a) Single-line diagram. (b) Secondary protection with high-side fuses (see [Figure 9.22](#)). (Continued on next page.)

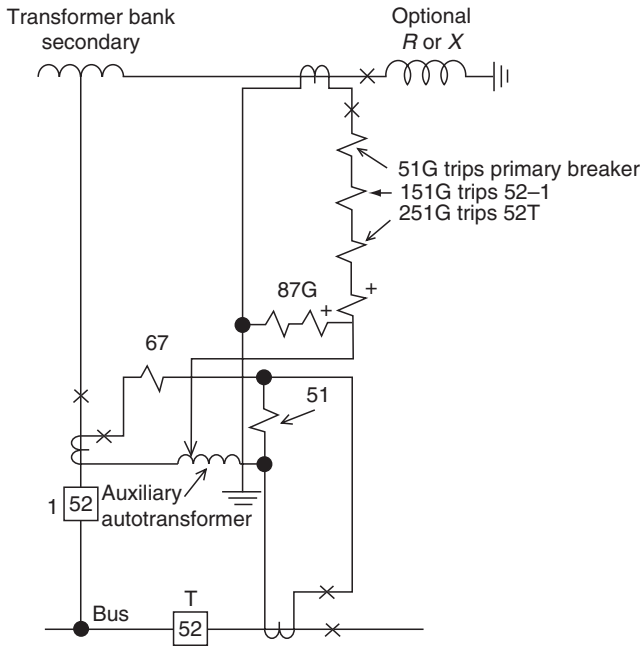

(c)

FIGURE 9.25 (continued) (c) Secondary protection with high-side breaker (see Figure 9.23).

by increasing the maximum load current. The 67 time setting must coordinate with the protection on the transformer primary. When used, the ground relay can be set on minimum setting and time, because coordination is not necessary.

The inverse-time–overcurrent relays (51, 51N) provide bus protection and backup protection for the feeder circuits. These relays trip both 52–1 (or 52–2) and 52T. This is a partial differential connection that is discussed in Section 10.11.4 and shown in Figure 10.10. These units must be time-coordinated with the protection on the several feeders that are connected to the bus. Only two-phase relays are required, but the third relay (shown optional in Figure 9.26) provides additional redundancy. When a ground differential is used, as illustrated in Figure 9.25c, 67N and 51N are omitted. The connections shown are compatible with Figure 9.13 through Figure 9.16.

Ground-fault backup is provided by 51G, 151G, and 251G inverse-time–overcurrent relays (Figure 9.25). Relay 251G provides bus ground-fault protection and backup for the feeder circuit ground relays. It must be time-coordinated with these. It trips the bus tie 52T, as the fault could be either on the bus or on the associated feeders. If the fault continues to exist with the bus tie open, relay 151G trips breaker 52–1 (or 52–2). Thus, 151G must

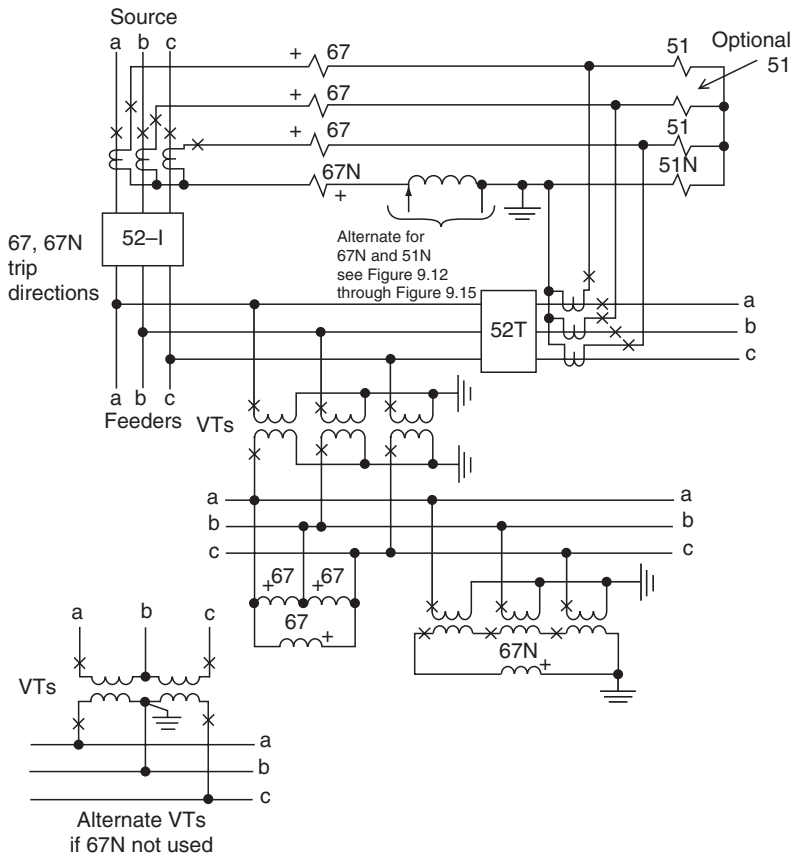

FIGURE 9.26 Three-line connections for reverse-phase and partial differential backup protection.

coordinate with 251G. If the fault persists, it is between the secondary breaker, in the transformer winding, or in the grounding impedance. Relay 51G set to coordinate with 151G is the last resort. It trips the high-side or primary breaker to remove the transformer from service.

9.24.3 REDUNDANCY REQUIREMENTS FOR BULK POWER TRANSFORMERS

When transformers are connected to bulk power systems, redundancy requirements for related protection as described in [Chapter 1](#) need to be addressed. To provide the required redundancy, two separate differential schemes may be applied. Redundancy for transformer faults may also be obtained by a differential scheme and sudden pressure. In such application, the sudden pressure protection needs to be supplied with additional protection for faults on the

transformer bushings and leads, as sudden pressure devices will not respond to faults in these areas. Redundant schemes for disconnecting the transformer from the system when a high-side breaker is not applied can be obtained by using various combinations of the methods discussed in Section 9.14. For example, although expensive, two separate transfer trip systems may be applied. A cheaper alternative is to combine a transfer trip scheme and a fault switch. It may be possible to delay closing the fault switch for a few cycles to allow time for the transfer trip scheme, provided it is operational, to deenergize the failed transformer before the closing of the fault switch. This would spare the power system from being subject to a solid fault when the fault switch closes, whenever the transfer trip scheme works properly. When a high-side breaker is applied and it fails to operate, breaker failure protection is required to enable isolation of a faulted transformer. The breaker failure scheme may require application of a fault switch, transfer trip scheme, or a second interrupting device if other local breakers are not available to isolate the transformer.

9.25 REACTORS

Reactors are primarily used in power systems (1) in grounded neutrals to limit fault current, (2) in series in the phases to reduce phase-fault current magnitudes, and (3) in shunt to compensate for the capacitive reactance of long transmission lines and pipe-type cable circuits. Reactors also serve as harmonic filter banks and to suppress secondary arc current in single-pole relaying.

Application (1) is covered in [Chapter 7](#) and in the present chapter. Phase-fault-limiting reactors (2) are used between buses, each of which have high-short-circuit levels, and in feeder circuits connected to similar high-short-circuit-capacity buses. In this section, we briefly review shunt reactors.

9.25.1 TYPES OF REACTORS

Shunt reactors are either dry or of oil-immersed types. The dry types, available to voltage of about 24.5 kV, are usually applied to transformer tertiary. They are single-phase air-core construction, with the winding exposed for natural convection either for indoor or outdoor mounting. The location should be in an area where the high-intensity magnetic field is not a problem or hazard.

As single-phase units, phase-type faults are not common, but may occur by simultaneous faults in more than one reactor or by a fault spreading to involve the bus. Thus, the principal hazards are ground and turn-to-turn faults. A common arrangement of tertiary-connected reactors is an ungrounded wye with the system grounded by a broken-delta resistor method (see [Figure 7.10](#)).

Oil-immersed reactors can be either single-phase or three-phase units in a tank, with an appearance similar to that of a transformer bank. Voltage is not

a limitation, thus this type is used for line connections. Solid grounding is normal. The principal hazards are phase or ground faults from insulation failure, bushing failure, turn-to-turn faults, low oil, and loss of cooling.

9.25.2 GENERAL APPLICATION OF SHUNT REACTORS

Generally, shunt reactors are connected directly (without breaker) to the line, or when the line is terminated without a breaker to a transformer bank with tertiary circuits, the reactors may be connected to the tertiary. Reactors may also be connected to a bus. With direct-line connection, problems in the reactor units require deenergizing the line by tripping the local breaker and transfer tripping all remote breakers that can supply fault current. Disconnect switches provide means of manual isolation, or circuit switchers may be used to disconnect the reactors automatically when the line has been opened. This may be necessary for automatic reclosing of the line; however, subsequent operation of the circuit without reactors can produce overvoltage. Deenergizing a circuit with shunt reactors produces a transient oscillation between the reactive and capacitive elements, with a frequency generally less than 60 Hz. This can be a problem for some of the protection. In addition, if there is an energized parallel circuit, this coupling can produce overvoltage or ferreresonance. An example was cited in [Chapter 7](#).

Reactors connected to transformer tertiary circuits usually result in very low fault levels in the higher-voltage circuits for reactor faults because of the relatively high impedance through the transformer windings to the tertiary. Breakers are usually available for isolation of these tertiary-connected units. However, removing the reactor can result in overvoltages on the line and associated system.

9.25.3 REACTOR PROTECTION

Where series reactors are connected in the phases, the protection is included as part of the line protection, which generally includes overcurrent protection for phase and ground faults, as covered in [Chapter 12](#).

For shunt types, protection is basically the same as for transformers with the size, importance to the system, and “personality” providing many variations and different approaches to the applied protection.

Differential (87) protection is the most widely used, with phase and, wherever applicable, ground overcurrent as backup or sometimes as the primary protection. Differential connections are as shown in [Figure 8.7a](#) or for ground differential, in [Figure 9.11](#). Instantaneous overcurrent (50) devices set above the inrush and transient currents, and inverse-time–overcurrent (51) devices set to coordinate with all other protection equipment overreached are both used.

Impedance relays set to “look into” the reactor are used for both primary and backup. They must be set below the reduced impedance that can occur during inrush and in such a way that they do not operate on the natural

frequency oscillations, which can occur when the compensated line is deenergized. Negative-sequence current relays are also occasionally applied.

Turn-to-turn faults are a concern in reactors as well as in generators, motors, and transformers. They can produce considerable current and damage in the area of the problem, but reflect very few indications (“handles”) at the terminals for detection until they develop and involve other phases or ground. Differential does not provide turn-to-turn fault protection.

Turn-to-turn fault protection for dry-type ungrounded shunt reactors can be provided by a voltage-unbalance scheme. This compares the reactor neutral to ground voltage and the voltage across a wye-grounded–broken-delta voltage transformer. A phase-shift circuit adjusts for reactor bank unbalances, nominally $\pm 2\%$. Normal system and external fault unbalances affect both the voltages equally. Thus, internal reactor faults produce a reactor neutral to ground voltage to operate an overvoltage (59) relay.

This scheme is not applicable for iron-core reactor because of variable impedances during transients and inrush. For the oil-immersed reactors, sudden pressure or gas-type relays provide the best turn-to-turn fault protection. Negative sequence has been used, but is relatively insensitive, as the amount of negative sequence measurable for turn-to-turn faults is very low for light faults. Impedance relays can provide protection by the change in reactor impedance. Probably the most sensitive protection for these very difficult-to-detect faults are mechanical relays (see [Section 9.15](#)), with gas accumulator or pressure relays applicable to oil-immersed units. For those reactors that are connected to bulk power systems, as with transformers, redundancy requirements need to be addressed.

9.26 CAPACITORS

Both series and shunt capacitors are used in power systems. Series capacitor banks in long high-voltage transmission lines reduce the total impedance between large power sources. This increases the power-transfer capabilities and enhances stability. This is discussed further in [Chapter 14](#). They are part of the transmission line and, as such, are protected as part of the line. On modern power systems, shunt capacitors are utilized at all voltage levels. Shunt capacitors are used to supply a portion of the reactive requirements of the power system and loads connected to the system. Shunt capacitors also provide for voltage and power factor control.

9.27 POWER SYSTEM REACTIVE REQUIREMENTS

Electrical loads connected to power systems typically operate at a lagging power factor. Rotating equipment requires exciting current to supply its magnetizing requirements. Magnetizing current has a highly lagging power

factor. The overall power factor of load connected to a specific circuit on a power system will depend on the nature of the load that is involved. Industrial load tends to have a lower lagging power factor than residential load, because of the higher percentage of rotating machinery that is associated with industrial load than with residential load.

Load flow through power system lines causes reactive losses. These losses are caused by current flowing through the inductive reactance component of the impedance of the power system circuit. The related values of inductive and capacitive reactance for overhead lines are such that at moderate to heavy load flow through the line, the total effect is that the load flow causes reactive losses to occur in the line. At light load levels, vars may be generated by the line. This is especially true for longer lines at higher-voltage levels, which can have a significant amount of capacitive reactance. Standard convention for indicating directionality of var flow is that positive vars are associated with the direction in which lagging current is flowing. Var flow through a line causes a voltage drop to occur along the line in the direction of var flow. When large amounts of vars are transmitted over power system lines, large voltage drops will occur, which can result in voltage levels on the power system that are excessively low. For this reason, it is advantageous to supply vars as near to the location of consumption as possible. Design of power systems requires that consideration be given to its reactive requirements and provisions be provided to supply these requirements in an effective manner. Effective application of facilities to provide reactive support will allow suitable voltage profiles to exist throughout the power system and will enhance the operating efficiency of the system by reducing losses. Overexcited generators, synchronous condensers, and shunt capacitors are the major sources of var supply for power systems. Application of synchronous condensers is relatively expensive and, as such, is not used to a great extent. The effectiveness of var supply from generators is limited because of the difficulty of transmitting vars over significant distances. Shunt capacitors are therefore used extensively on power systems for supplying var support.

9.28 SHUNT CAPACITOR APPLICATIONS

Shunt capacitors are connected as required throughout the power system. Shunt capacitors have been utilized at the distribution level for many years. In recent years, larger shunt capacitor banks have been applied at the higher-voltage levels.

At the distribution level, capacitors are applied in various ways depending on the voltage control philosophy of the utility. A typical plan might require that capacitors be installed on distribution lines to the extent that a defined power factor (i.e., unity power factor) be maintained at the distribution substation. Fixed capacitor banks would then be connected to the

distribution line based on the voltage profile that exists along the line during light load conditions. The size and location of the capacitors would be based on maintaining a satisfactory (relatively) flat voltage profile along the line such that satisfactory voltage levels are supplied to customers during light load conditions. Switched capacitor banks are then applied on the line to obtain a satisfactory voltage profile for heavy load conditions. Switched banks are often controlled by time clocks with voltage override. A sufficient amount of shunt capacitance is installed on all lines that are supplied from a substation to obtain the desired voltage profiles and overall power factor at the substation.

At the subtransmission level, shunt capacitors are installed to supply reactive load that is supplied directly from the subtransmission system and to supply reactive losses that are incurred on the subtransmission system during heavy load conditions. These capacitor banks may be a combination of fixed and switched banks and are located on the system to reduce reactive losses in an efficient manner and to maintain a satisfactory voltage profile throughout the subtransmission system for all load conditions. Bulk power capacitor banks can be applied in a manner similar to that described for subtransmission systems. Capacity to supply reactive load would not be a consideration on the bulk power system if load were not directly supplied from this system. Some of the reactive losses on the bulk power system may be supplied from generators that are connected to this system.

9.29 CAPACITOR BANK DESIGNS

Capacitor “units” are the basic building blocks of capacitor banks. A capacitor unit is enclosed in a case with a number of internally connected series groups of capacitors. Each group is made up of a number of individual capacitor “packs” that are connected in parallel. A typical arrangement of a capacitor unit is illustrated in [Figure 9.27](#). The arrangement of the internal construction of capacitor units and dielectric material varies among manufacturers. Modern capacitor units utilize an all-film dielectric rather than the paper-film dielectric, which had been used in the past.

Pole-mounted distribution capacitor banks are made up of one or more parallel connected capacitor units per phase. The bank may be connected in wye or delta. Protection for distribution capacitor banks is normally provided by installing a fuse in each incoming phase wire to the bank.

Large capacitor banks for use at high-voltage levels are made up of numerous capacitor units connected in parallel groups with a number of such groups connected in series in each phase. The capacitor units for such large banks can be “externally fused,” “internally fused,” or “fuseless.” In externally fused banks, a fuse is installed on each capacitor unit. Internally fused banks utilize a fuse on each capacitor pack that is internal to the unit. Fuseless banks do not use any fuses on the units or packs. A variety of

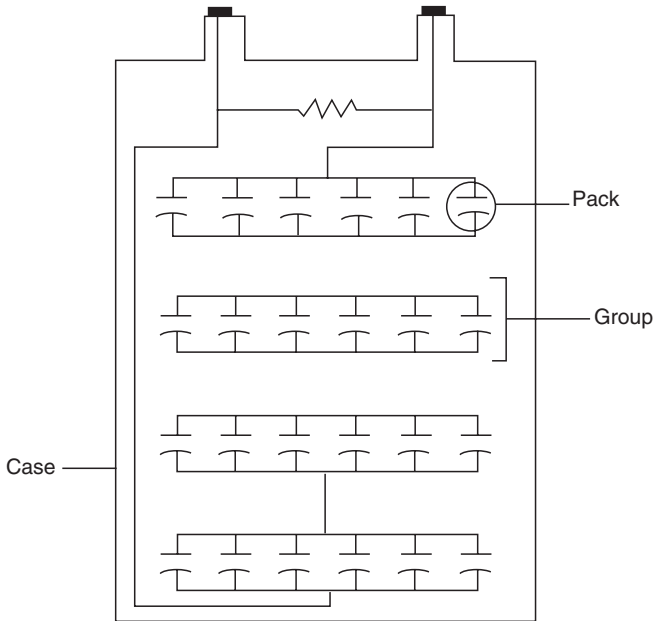

FIGURE 9.27 Generalized schematic illustration of a typical capacitor unit.

arrangements is used for the manner in which large banks are arranged and connected.

9.30 DISTRIBUTION CAPACITORS BANK PROTECTION

Fuses used to protect pole-mounted distribution capacitor banks are applied to protect capacitor units from case rupture. A ruptured case can result in the spilling of dielectric fluid, which can ignite and burn, potentially causing damage to other adjacent cans and represents a safety hazard to personnel and to the general public. A vacuum switch or other suitable disconnecting device may also be installed on the capacitor bank to switch it in and out of service.

A unit failure will usually start with the breakdown of the dielectric of one pack. This pack failure causes the associated parallel group of packs to be shorted, which consequentially causes the voltage across the remaining series groups to increase. This increased voltage leads to cascading failures of other packs until the entire unit is shorted. During this process, there is a good probability that the unit case will rupture. The probability for case rupture is difficult to predict and can vary considerably depending on specific design details of the unit involved.

The ampere rating of the fuse that is used to protect a distribution capacitor bank must be capable of carrying the maximum current that the bank may draw. Because of manufacturing tolerances and variations in system operating voltages, this current can be considerably higher than the nominal current of the bank. To allow for these variations, the continuous current-carrying capability of the fuse, as a minimum, should be about 125% of the nominal current rating of the capacitor bank. The capacitor fuse must also be capable of withstanding the maximum energizing inrush current and transient outrush current to avoid nuisance fuse operations. Experience has shown that fuses with continuous current ratings that are above 125% of the banks' nominal rating will meet the withstand criteria for typical applications of capacitor banks on distribution systems.

To optimize protection obtained for the bank, a fuse with a characteristic that operates as rapidly as possible in response to an evolving capacitor failure and that best coordinates with the case rupture characteristic should be chosen. To evaluate fuses with respect to speed of operation, the operating time of fuses should be compared for currents drawn, as subsequent groups of packs fail in a unit. The best fuse is the one that operates in the lowest time. To evaluate fuses for protection against case rupture, it is necessary to obtain the case rupture characteristic from the manufacturer and compare this characteristic against the total clear time-current characteristics of the fuses. When capacitor banks are connected at locations in the system where high fault current levels are available, it may not be possible to obtain complete protection against bank rupture. In such cases, application of fault current limiters or current limiting fuses could be considered to enhance protection for the bank. Best protection is obtained when the number of parallel units connected per phase is minimized. With the typical size of distribution capacitor banks ranging between 300 and 1800 KVAR, and with modern individual units available in sizes up to 300 KVAR and more, banks can be constructed by using one or two units per phase. To protect the power system from faults on a distribution capacitor bank, the fuse on the bank must be coordinated with the next protective device that exists on the distribution line between the capacitor and the supply substation.

From a practical standpoint, many utilities choose to utilize the same type of fuse on capacitor banks as are utilized elsewhere on the distribution system to protect transformers and single-phase taps. This avoids the necessity to stock different types of fuses for different types of applications. Such a practice is practical if the associated fuse characteristic provides satisfactory protection for capacitor banks based on the criteria described earlier in this section. Utilities often specify standard fuse ratings for protecting capacitor bank sizes that are applied on their system. Typically, the utility may select a fuse for a specific bank size such that it is the smallest-sized fuse with a current rating above 125% of the nominal current rating of the associated capacitor bank. For delta-connected banks, it must be recognized that the fuse

current will exceed the current through each individual phase-to-phase connected capacitor by a factor of the square root of three.

9.31 DESIGNS AND LIMITATIONS OF LARGE CAPACITOR BANKS

Capacitor banks connected to higher-voltage systems are considerably larger than those connected to distribution systems. The capacities of such capacitor banks vary over a wide range and are generally connected to the system at substations. The sizes of these banks typically vary from about 20 to over 400 MVA. As large banks represent a greater investment than the smaller-sized banks that are dispersed throughout the distribution systems, they warrant more sophisticated protection. Large capacitor banks are built by combining a great number of the similar type of capacitor units that are used in smaller banks. Fused banks are made up of a number of series connected groups of capacitor units. A group consists of a number of units connected in parallel. Additional series connected groups can be installed in parallel per phase until the desired bank capacity is obtained. Fuseless banks require that the capacitor units be connected in series strings. A number of series strings of units can be paralleled to obtain the desired bank capacity. Fuseless units offer advantages of smaller size, greater simplicity, lesser losses, low probability of case rupture, no possibility of nuisance fuse operations, and the possibility of achieving more sensitive protection.

The most common types of large capacitor banks that have been applied in the past are externally fused banks connected in wye. In recent years, fuseless banks are used to a greater extent due to the advantages noted earlier. Fuseless designs have been made possible with the development and use of film/foil dielectric materials in the capacitor design. Use of such material assures that, when a pack fails, it will create a short with a weld that is solid enough to carry rated current. This results in minimal gas buildup within the unit case because of the failure, which allows for continued operation but with a loss of one of the many series connected groups of packs. Internally fused capacitor units use a fuse on each individual pack within the unit.

Industry standards require that capacitor units be manufactured with the capability of operating indefinitely at 110% of the nameplate voltage rating. Damage may therefore possibly occur if a capacitor unit is subject to a voltage greater than 10% above its rating. Prevention of continued operation when the voltage applied to units within a bank may exceed this 10% limit is a major focus of the protective systems that are applied on capacitor banks. Standards also require that capacitor units be capable of continuous operation at 135% of its KVAR rating.

The design of large capacitor banks and their associated protection is developed to obtain operating characteristics that meet the following criteria:

1. The loss of any single capacitor unit within the bank should not cause the voltage of other units to exceed 10% of its rating. Protection should function to initiate an alarm to set off when one or more units have failed and the voltage applied to any other unit within the bank does not exceed its 10% overvoltage rating.
2. Protection should function to initiate a trip of the capacitor bank when units have been lost to the extent that the overvoltage on any other unit within the bank may exceed its 10% overvoltage rating.

The above design criterion prevents tripping of the bank upon the loss of one or more units when damaging voltages on other units do not exist. An alarm is initiated for such conditions so that the failed units may be replaced at a convenient time. The capacitor bank is tripped, however, when failures of units occur to the extent that voltages on other units exceed their 10% overvoltage rating and damage is highly possible.

A typical arrangement for an externally fused bank is shown in Figure 9.28. S is equal to the number of series groups connected in one phase of the bank and P is equal to the number of capacitor units per group. The voltage

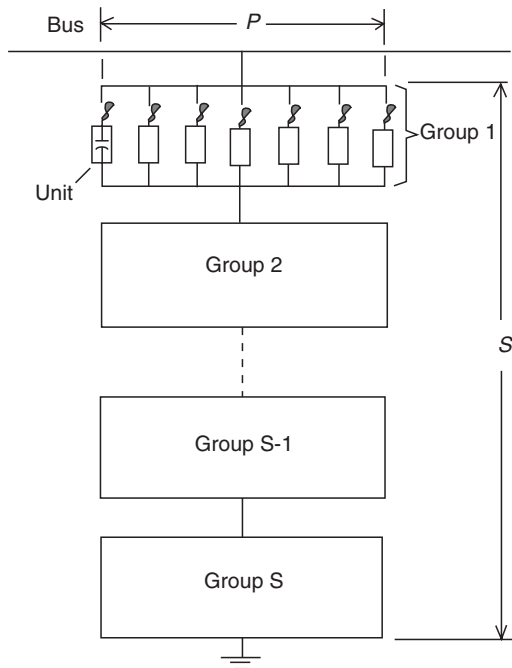

FIGURE 9.28 Arrangement of one phase of an externally fused, wye-grounded, capacitor bank.

across other units in a group when fuses have blown is given by the following formula:

$$V_{\text{pu}} = \frac{S(P)}{S(p-n) + n}, \quad (9.30)$$

where V_{pu} = per unit voltage across capacitor units in a group with n open fuses in the group.

Example:

Each phase of a capacitor bank is made up of six units per group and five series groups. With one blown fuse in one group, the voltage across the other units in the group will be equal to:

$$V_{\text{pu}} = \frac{5(6)}{6(6-1)} + 1 = 1.154.$$

This would not be a desirable arrangement because one blown fuse causes the voltage on the other units in the group to increase 15.4% above nominal, which is above the 10% design limit. It would be therefore necessary to trip the bank upon the opening of any fuse on a unit within the bank. Excessive tripping of the bank would probably be experienced as tripping would occur immediately upon the opening of a single fuse. It would not be possible to alarm for a fuse failure, which would call for replacing the failed unit at a convenient time when the bank is not required to be in service. If the number of units per group was increased to 10:

$$V_{\text{pu}} = \frac{5(10)}{5(10-1)} + 1 = 1.087 \text{ or } 8.7\% \text{ above nominal.}$$

As 8.7% is less than the 10% damage threshold, tripping of the bank would not be required for one blown fuse.

In the above bank ($S=5$, $P=10$), if a second fuse opens in the same group as the first blown fuse:

$$V_{\text{pu}} = \frac{5(10)}{5(10-2)} + 2 = 1.19 \text{ or } 19\% \text{ above nominal.}$$

The bank would need to be tripped for a second blown fuse in a group as 19% exceeds the 10% design limit. It is evident that in externally fused banks, a minimum of about 10 units need to be paralleled per group to obtain the desired design criteria. The maximum number of units that can be paralleled per group is dictated by the probability for case rupture and will vary depending on the manufacturer of the capacitor unit.

In fuseless banks, with all units connected in series strings, when a pack shorts, the associated group of packs is effectively removed from service and

the voltage will divide among the remaining groups of packs within the series string. The voltage that is applied across the remaining series connected groups of packs will increase by a factor of $n/n-1$ where n is equal to the number of series connected groups of packs per phase. It is desirable to set to alarm on the failure of a pack and to trip when the voltage across a unit in the series string exceeds 110% of its voltage rating.

Internally fused banks are designed with relatively more groups of units connected in series and lesser units per group than externally fused banks. Internally fused capacitor units employ a large number of packs in a parallel group and a small number of series groups. The large number of packs connected in parallel provides for a high current flow and prompt fuse operation when an individual pack fails.

Internally fused banks are subject to overvoltages on individual capacitor units and on fuses and packs within each unit. The capacitor bank must be tripped when a unit is subject to greater than 10% overvoltage or the voltage across a group of packs exceeds the design limit of the packs as specified by the manufacturer. When an internally fused capacitor bank trips, units with failed packs need to be identified by time-consuming tests on all units as blown fuses are not visible. Internally fused banks have not been extensively used in general practice.

9.32 PROTECTION OF LARGE CAPACITOR BANKS

Protective systems are applied on large capacitor banks to provide the following functions:

1. Protect the capacitor bank from excessive damage due to failure within the capacitor bank itself
2. Protect the capacitor bank from damage due to power system conditions that may be harmful to the bank
3. Protect the power system from damaging stresses that may be imposed on the system by the capacitor bank

The protection outlined in (1) is referred to as “bank” protection and the protections outlined in (2) and (3) are referred to as “system” protection.

Fuses provide a degree of bank protection on externally and internally fused banks. Unbalance protection is used to provide for the required alarming and tripping. As previously noted, alarming is initiated upon loss of a unit or packs within the bank. Tripping is initiated when the unbalance is of an extent that damage to capacitor bank units is likely due to overvoltage or a fuse malfunction. Unbalance protection may also be capable of detecting an external arcing or cascading fault. Unbalance protection can take many forms depending on the design, size, and connection of the capacitor bank. A discussion of all possibilities is beyond the scope of this book. IEEE C37.99 provides details on various

forms and connections for providing unbalance protection. The following is a general discussion of some typical common applications.

A common connection used for large capacitor banks is grounded wye. Unbalances in such banks can be detected by monitoring current flow in the neutral connection of the bank. When the bank is perfectly balanced and energized by a balanced voltage source, no neutral current will exist. Neutral current increases as the bank becomes unbalanced as a result of fuse operations within the bank or because of shorted groups of packs in a fuseless bank. A current or voltage relay connected to sense current flow in the neutral should be set, based on the expected neutral current flow for fuse operation or shorted packs within the bank. Settings need to be selected appropriately for initiating an alarm and trip based on the criteria previously discussed.

Application of capacitor bank unbalance protection using neutral current sensing techniques presents several challenges:

1. Neutral current values for which relay action is required are very low. Instrument transformer and relay performance can be problematic when currents of such low magnitude need to be measured to initiate operation of the scheme.
2. A natural unbalance will exist within capacitor banks because of manufacturing tolerances and the unbalance that typically exists in the voltages throughout the power system network.

The neutral current value for which operation is required may be within a similar range to that of the exciting current of the neutral current transformer. The normal unbalance current of a capacitor bank may also be in the same general range as that required to initiate alarming and tripping. As such, use of neutral current unbalance protection on some capacitor banks may not be applicable. This is especially true for larger banks for which the level of current required for operation can be very small. Capacitor bank neutral current will exist during power system faults that cause voltage unbalances on the system. A sufficient time delay needs to be applied on a neutral current unbalance scheme to override the maximum clearing time expected for such faults.

An alternative and a more effective way to obtain unbalance protection is to use a voltage differential scheme. The basis for voltage differential unbalance protection is that, under normal conditions, the voltage across each phase of the capacitor bank will divide rather evenly across the series groups that are connected in the phase. An even distribution of voltage exists because the same amount of units are connected in each group and, therefore, the impedance of each group will be relatively equal. When fuses operate within a bank, or, in the case of a fuseless bank, a pack group is shorted, the voltage across each of the series connected elements of the capacitor bank will no longer be equal.

Figure 9.29 illustrates a typical connection of a voltage differential relay in one phase of a capacitor bank. In such a scheme, the bus voltage is compared in the relay to a voltage at some tap point among groups within the bank. The midpoint of the bank is often chosen for this tap point. The relay input voltages are adjusted within the relay or by the potential transformer ratios to account for the difference in primary voltage that is expected on the high-side bus and at the tap point. For example, if the tap was connected to the midpoint of a perfectly balanced bank, the relay will measure zero differential voltage when the primary tap voltage is equal to one-half of the primary bus voltage. When unbalances occur in the bank because of failures, the same ratio between the tap and bus voltages will no longer exist and the relay will consequently measure a differential voltage. Based on the design of the bank, the differential voltage during failures can be calculated and associated settings applied to the relay to initiate alarming

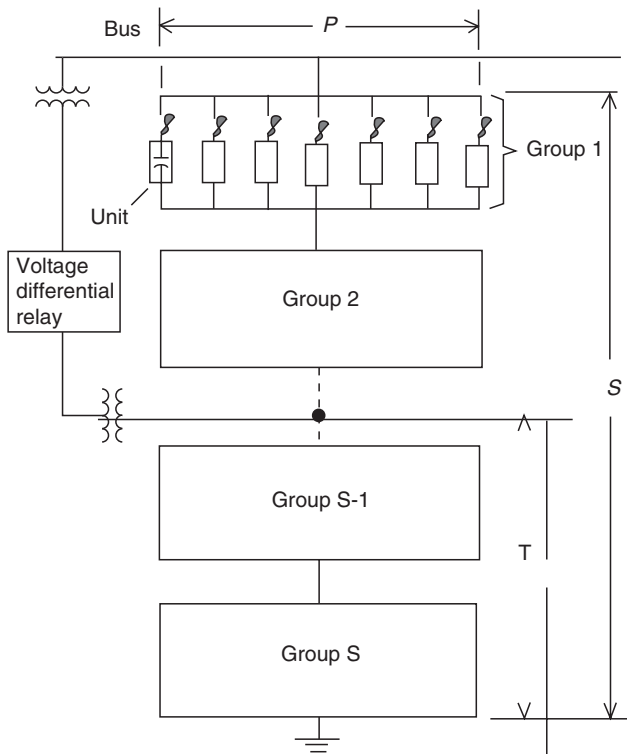

FIGURE 9.29 Connection of a voltage differential relay in one phase of an externally fused, wye-grounded, capacitor bank.

and tripping to meet the criteria previously described. C37.99 should be referenced to identify appropriate formulas that have to be used to make these calculations for the specific capacitor design that is analyzed.

An important feature of a voltage differential scheme is that compensation can be applied to the relay to allow for manufacturing tolerances in the installed capacitor units. Compensation is set on the relay by adjustments provided to establish sensing of zero differential voltage with the bank normal, in service, and energized. In addition, unbalanced system voltages do not create a problem as the relay is looking at a ratio of bus to tap voltage separately for each phase. One problem with the midpoint tap design as described earlier is that holes may exist in its coverage for multiple failures that result in equal changes in the impedance above and below the midpoint tap location. The probability of such holes can be significantly reduced by tapping the bank at more than one location and comparing voltages between each tap location.

For a string of capacitor groups in an externally fused bank with one tap used for a voltage differential scheme, the per-unit change in voltage at the tap can be determined by using the following formulas:

Fuse blown on a unit in a group that is located between the tap and power system (above the tap):

$$-dV_{pu} = \frac{n}{S(P - n) + n}. \quad (9.31)$$

Fuse blown on a unit in a group that is located between the tap and neutral (below the tap):

$$-dV_{pu} = \frac{n \left(\frac{1 - S}{T} \right)}{S(P - n) + n}, \quad (9.32)$$

where n is the number of fuses blown, S is the total number of series groups, P is the number of paralleled units per group, T is the number of groups below the tap location.

Application of the formulas given here can best be illustrated by an example. Considering a capacitor bank with $S = 8$ and $P = 12$, with a midpoint tap used for a voltage differential scheme. Suitable settings for the voltage differential relay are determined as follows:

Per-unit voltage across bank groups without blown fuse: (Equation 9.30)
One blown fuse

$$V_{pu} = \frac{8(12)}{8(12 - 1)} + 1 = \frac{96}{89} = 1.078 \quad (7.8\% \text{ voltage rise}).$$

Two blown fuses

$$V_{pu} = \frac{8(12)}{8(12-2)} + 2 = \frac{96}{82} = 1.17 \quad (17\% \text{ voltage rise}).$$

Relay should be set to start the alarm on one blown fuse and trip on two blown fuses.

Differential voltage for blown fuses above and below tap (Equation 9.31 and Equation 9.32)

One blown fuse above tap:

$$-dV_{pu} = 1/8(12-1) + 1 = 1/89 = 0.01124 \quad (\text{tap voltage drops by } 0.01124 \text{ per unit}).$$

One blown fuse below tap:

$$-dV_{pu} = 1(1-8/4)/8(12-1) + 1 = -1/89 = -0.01124 \quad (\text{tap voltage rises by } 0.01124 \text{ per unit}).$$

Two blown fuses above tap:

$$-dV_{pu} = 2/8(12-2) + 2 = 2/82 = 0.0244 \quad (\text{tap voltage drops by } 0.0244 \text{ per unit}).$$

Two blown fuses below tap:

$$-dV_{pu} = 2(1-8/4)/8(12-2) + 2 = -2/82 = -0.0244 \quad (\text{tap voltage rises by } 0.0244 \text{ per unit}).$$

Voltage differential relay should be set to start the alarm for one blown fuse. Considering 115 V as base:

$$\text{Differential voltage for one blown fuse} = 115 \text{ V} (0.01124 \text{ pu}) = 1.29 \text{ V}$$

Set to start the alarm at 50% of differential voltage for one blown fuse:

$$0.5(1.29 \text{ V}) = 0.65 \text{ V} = \text{Alarm setting for differential relay.}$$

Voltage differential relay trip setting should be set safely above differential voltage for one blown fuse and below differential voltage for two blown fuses:

$$\text{Differential voltage for two blown fuses} = 115 \text{ V} (0.0244 \text{ pu}) = 2.81 \text{ V}$$

Set to trip midpoint between voltage change for one blown fuse and for two blown fuses:

$$(2.81-1.29)/2 + 1.29 = 2.05 \text{ V} = \text{Trip setting for differential relay.}$$

Similar analysis should be performed for fuseless banks and internally fused banks to determine suitable settings for associated voltage differential relaying.

Several types of relaying schemes are applied on large capacitor banks to provide system protection.

1. *Overcurrent protection.* Phase and neutral overcurrent relaying connected on the high side of the capacitor bank. This relaying protects the bank and the system from damage that can be caused by severe phase-to-phase or phase-to-ground faults on the bank. The time-over-

current phase relay should be set with a pickup of about 135% of the capacitor bank rating. Instantaneous overcurrent phase relays must be set higher than the maximum expected transient inrush and outrush currents. Neutral overcurrent relays should be set as low as possible without causing nuisance tripping on system faults or transients.

2. *Overvoltage protection.* High voltages may exist at the capacitor high side because of abnormal or unusual operating conditions. The capacitor bank itself may be a contributing factor to the overvoltage condition. A three-phase overvoltage can be applied on the high side of the capacitor bank to protect the bank and system from such overvoltage conditions. Setting should be coordinated with the voltage design limits of the system and the capacitor bank.
3. *Loss of bus voltage protection.* It is sometimes desirable to trip the capacitor when voltage is lost at its high-side bus. Such tripping may be necessary to prevent undesired transients that may result if the bank is reenergized by automatic reclosing schemes applied on the power system. An undervoltage relay that monitors bus potential is used to provide loss of voltage protection. A time delay is applied on undervoltage tripping to provide sufficient time to override voltage drops because of faults on the system. The time delay must be fast enough to trip the capacitor before automatic reclosing is initiated on the power system.
4. *Breaker failure protection.* Conventional breaker failure protection can be applied to provide isolation of the bank when the capacitor breaker fails to open or interrupt.

9.33 SERIES CAPACITOR BANK PROTECTION

Series capacitor banks are connected in series with transmission lines. Considering the related cost and benefits, application of series capacitors is limited to long, high-voltage, transmission lines. The series capacitance compensates the inductive reactance of the transmission line causing a reduction in its series impedance. This reduction in impedance allows for an increase in power transfer capability and transmission efficiency over long distances. Application of series capacitors on a power system requires that studies be conducted on available fault current levels, potential for harmonic interactions, and the possibility of subharmonic or subsynchronous resonance.

Series capacitor banks are removed from service by closing a switch which is installed to bypass the bank. This allows the transmission line to remain in service for failures in the bank. As the series capacitor is part of the transmission line, and can be bypassed at any time by automatic control, the protection provided on the associated transmission line must be applied and set with consideration given to conditions with the capacitor bank in service and out of service.

Series capacitor banks are constructed with the same basic capacitor units as used in shunt capacitor banks. As with shunt banks, the capacitor units may be externally fused, internally fused, or fuseless.

A major protection concern with series capacitors is the potential for damage to the bank as a result of overvoltages caused by fault current flow through the bank during power system faults. Closing of the bypass switch is too slow to provide protection against such overvoltages. Devices that have an immediate response to the increase in voltage during the fault condition need to be applied to provide the required protection. Air gaps, varistors, and, in more recent years, thyristor valves are used to provide the required instantaneous response for providing overvoltage protection. The overvoltage protective devices are not continuously rated, and, as such, are subject to overheating and need to be protected by closure of the bypass switch. Measurement of current through the bank and through the overvoltage devices provides the intelligence to trigger closing of the bypass switch. The current measurements and associated calculations for providing this protection depend on the characteristics of the specific overvoltage device that is protected.

Results of failed packs within the capacitor units that make up a series bank are similar to that for shunt banks, as previously discussed. As in shunt banks, pack failures result in the bank becoming unbalanced. Unbalance protection is applied to initiate an alarm and trip if the potential for cascading failures develops. Unbalance protection can take various forms depending on the design of the bank. In general, such protection detects unbalanced conditions by monitoring current flow through portions of the bank through which equal or no current flow would exist under balanced conditions.

Overload protection is provided on series capacitor banks to prevent excessive deterioration of the dielectric because of short-term or sustained overvoltages caused by overload. Overcurrent relays that operate on a cumulative value of overload are applied to provide this protection. The relay is set at an alarm and trip level. A trip operation initiates closing of the bypass switch.

The series capacitor bank platform is operated at line potential and solidly connected to one side of the bank. The use of a single point of connection allows the use of a current transformer to measure platform current. For a failure in which a flashover to platform occurs, normal line current may flow through this connection. For platform-to-ground failures, the available phase-to-ground current will flow through the connection. Under normal operating conditions, the current through this connection equals the platform charging current, which is relatively very low. An instantaneous overcurrent relay that is connected to monitor current through the platform to bank connection is used to provide platform fault protection.

Control and protection logic provided on series capacitor banks vary, based on the protection philosophy of the associated utility. The previous discussion is intended to provide a general overview of the more significant

protection issues involved. IEEE PC37.116 provides more detailed information on this subject.

9.34 CAPACITOR BANK PROTECTION APPLICATION ISSUES

Application of large capacitor banks on power systems began to evolve into more common usage about the time that solid stage relays were developed. Considerable problems were experienced by some of the early installations of large banks because of the sensitivity of the settings required. Tolerances within the relays were such that environmental conditions at the relay location were sufficient to cause the operating characteristics of the relay to change sufficiently such that misoperations were common. In some instances, unbalances that evolve within the capacitor bank itself were not adequately accounted for when designing the protective systems, resulting in many false operations. For example, impedance unbalance within the bank can be caused by its physical orientation allowing sunshine to cause uneven heating of the unit throughout the bank during different times of the day. Variations can be sufficient to defeat compensation that is applied and cause the scheme to operate incorrectly. It was also discovered that connections in control circuitry that supplied voltage-measuring devices had to be very solid, or else contact resistance because of corrosion or other causes could be enough for the scheme to function incorrectly. Many of these problems were uncovered through experience by individual utilities. For a period, however, and even today, a large number of trips on large capacitor banks could not be traced to a specific problem in the bank. Use of microprocessor based relays has mitigated the relay sensitivity and drift problem to a large extent. Such relaying has also allowed for more logic sophistication to be designed into the protection logic to enhance the operating security of the scheme. It is also common to find a large number of blown fuses or considerable damage at banks when a tripout is investigated. This is probably caused by the large amount of stored energy that exists within the bank and significant amount of transient surges that are possible when switching or failures occur.

BIBLIOGRAPHY

- See the Bibliography at the end of [Chapter 1](#) for additional information.
- ANSI/IEEE Standard C37.91, Guide for Protective Relaying Applications to Power Transformers, IEEE Service Center.
 - ANSI/IEEE Standard C37.99, Guide for Protection of Shunt Capacitors, IEEE Service Center.
 - ANSI/IEEE Standard C37.109, Guide for the Protection of Shunt Reactors, IEEE Service Center.
 - ANSI/IEEE Standard C57.12, General Requirements for Liquid-Immersed Distribution, Power and Regulating Transformers, IEEE Service Center.

- ANSI/IEEE Standard C57.109, Transformer Through Fault Current Duration Guide, IEEE Service Center.
- Griffin, C.H., Development and application of fault-withstand standards for power transformers, *IEEE Trans. Power Appar. Syst.*, PAS 104, 1985, pp. 2177–2188.
- IEEE Power System Relaying Committee, Shunt reactor protection practices, *IEEE Trans. Power Appar. Syst.*, PAS 103, 1984, pp. 1970–1976.
- Sonnemann, W.K., Wagner, C.L., and Rockefeller, G.D., Magnetizing inrush phenomenon in transformer banks, *AIEE Trans.*, 77, P. III, 1958, pp. 884–892.

10 Bus Protection

10.1 INTRODUCTION: TYPICAL BUS ARRANGEMENTS

Busess exist throughout the power system and, particularly, wherever two or more circuits are interconnected. The number of circuits that are connected to a bus varies widely. Bus faults can result in severe system disturbances, as high fault current levels are typically available at bus locations and because all circuits supplying fault current must be opened to isolate the problem. Thus, when there are more than six to eight circuits involved, buses are often split by a circuit breaker (bus tie), or a bus arrangement is used that minimizes the number of circuits, which must be opened for a bus fault. There are many bus arrangements in service dictated by the foregoing and by the economics and flexibility of system operation. The major types are illustrated in [Figure 10.1](#) through [Figure 10.8](#). Four circuits for each bus have been chosen arbitrarily for convenience and comparison. The bus circuit breakers usually have disconnect switches on either side, as shown, to provide means of isolating them from the system after trouble or for maintenance. Generally, these switches are operated manually at no load. The circuits shown connecting to the buses can be generators, transformers, lines, motors, and so on.

The buses typically illustrated are

Single bus–single breaker	Figure 10.1
Double bus with bus tie–single breaker	Figure 10.2
Main and transfer bus–single breaker	Figure 10.3
Double bus–single breaker	Figure 10.4
Double bus–double breaker	Figure 10.5
Ring bus	Figure 10.6
Breaker-and-a-half bus	Figure 10.7
Bus and transformer–single breaker	Figure 10.8

Other arrangements exist and can be considered as combinations or variations of these.

Fortunately, bus faults are not too common, but are serious, because they can result in considerable loss of service through the circuits that must be opened to isolate the fault. The most common causes of bus faults are

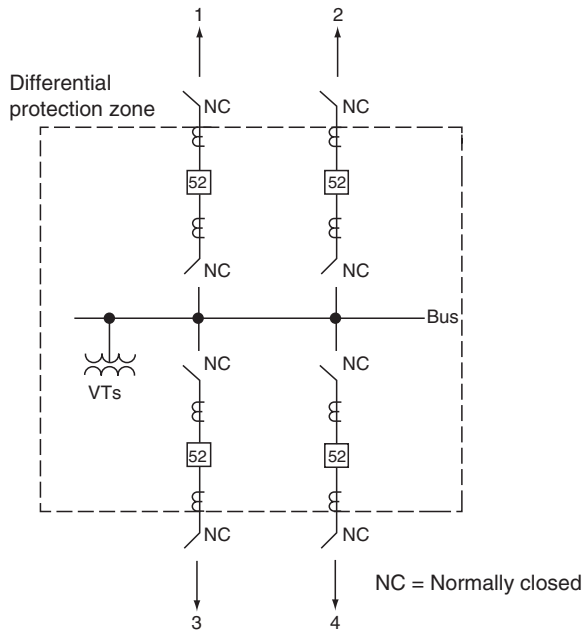

FIGURE 10.1 Typical four-circuit single breaker–single bus and the bus differential protection zone.

equipment failures, small-animal contacts, broken insulators, wind-driven objects, and contamination.

Differential protection provides sensitive and fast phase and ground-fault protection and is generally recommended for all buses. In the figures, the dashed-line box or boxes outline the bus differential protection zone: the primary protection zone. Backup is usually provided by the protection associated with the connecting circuits. A second differential scheme is sometimes used for very important buses and may be dictated by redundancy requirements specified for bulk power systems. Buses at distribution substations and within industrial complexes are sometimes protected by less complex, time delayed protection.

10.2 SINGLE BREAKER–SINGLE BUS

The single-breaker-bus type (Figure 10.1) is the most basic, simple, and economical bus design and is used widely, particularly at distribution and lower-transmission voltages. For this type of bus, differential is easy to supply as long as suitable CTs are available, with the protective zone enclosing the entire bus, as shown.

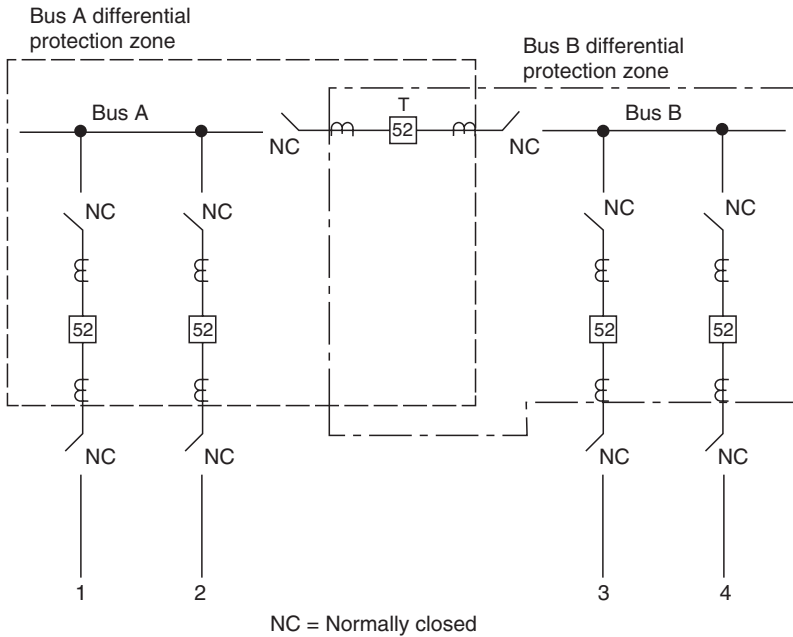

FIGURE 10.2 Typical four-circuit single breaker–double bus with bus tie and the bus differential protection zones.

This bus arrangement provides no operating flexibility. All bus faults require opening all circuits connected to the bus. Breaker problems or maintenance requires that the circuit be removed from service. However, maintenance may not be too much of a problem if maintenance on the entire circuit and the protection can be scheduled together. One set of voltage transformers (VTs) on the bus can supply voltage for the protection on all the circuits.

10.3 SINGLE BUSES CONNECTED WITH BUS TIES

This is an extension of the single bus–single breaker arrangement (Figure 10.2). It is used where a large number of circuits exist, especially at lower voltages, such as for distribution and industrial substations. It provides flexibility when the substation is fed from two separate power supplies. One supply that is connected to each bus permits operation with the bus tie (52T), either open or closed. If one supply is lost, all circuits can be fed by the other, with 52T closed. Separate differential zones for each bus are applied. A fault in one bus zone still permits service to the station by the other bus.

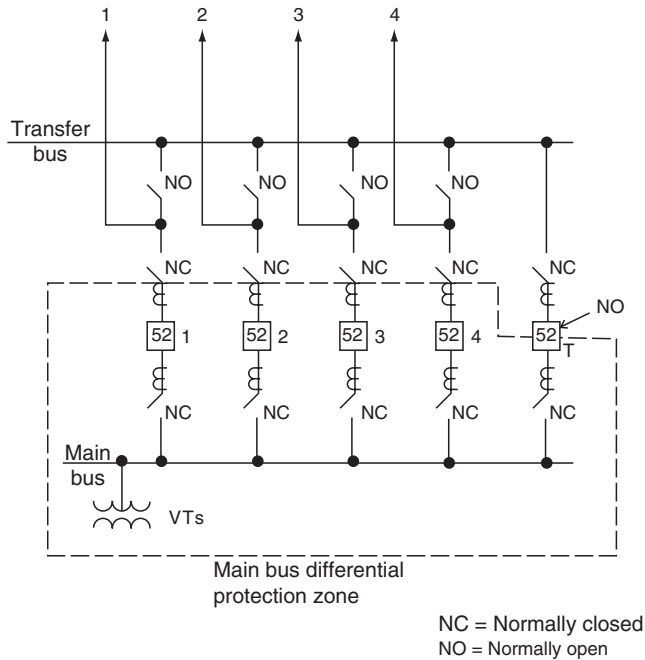

FIGURE 10.3 Typical four-circuit single breaker—main bus with transfer bus and the bus differential protection zones.

10.4 MAIN AND TRANSFER BUSES WITH SINGLE BREAKERS

Increased operating flexibility is provided by the addition of a transfer bus (Figure 10.3). Normal operation is similar to that shown in Figure 10.1, with all circuits supplied from the main bus. This bus is protected by a single differential zone (dashed lines). A bus fault requires tripping all breakers, thereby interrupting all service connected to the bus.

Normally, the transfer bus is not energized. For any breaker trouble or maintenance, that circuit is connected to the transfer bus by closing its normally open (NO) disconnect switch and closing the bus tie (52T) breaker to continue service. Only one circuit is thus connected to the transfer bus at any one time. The protection associated with the bus tie breaker must be suitable and adaptable for the protection of any of the circuits of the main bus. This can require different settings, which must be made for each circuit transferred or operating with compromise protection for the period of transfer bus operation. This is a disadvantage from a protection standpoint. In general, it is not desirable to switch or modify protection systems because the potential for error can result in no protection or misoperation. The use of microprocessor based relays can mitigate this problem because multiple setting groups

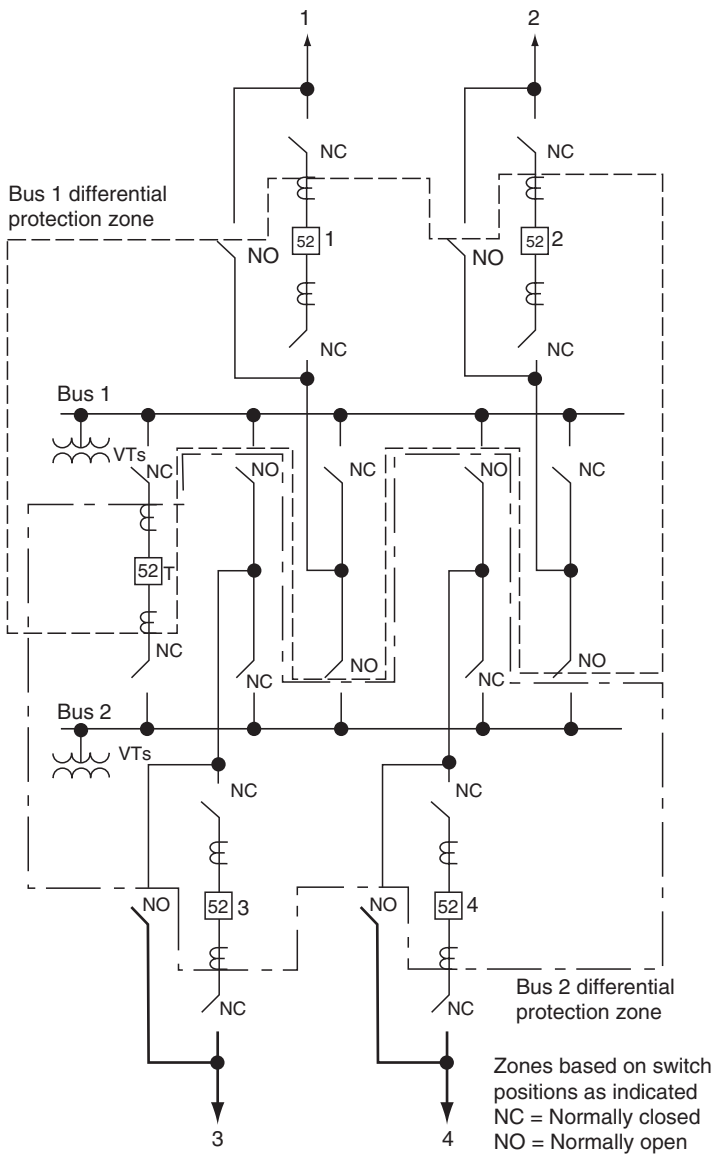

FIGURE 10.4 Typical four-circuit single breaker–double bus and the bus differential protection zones.

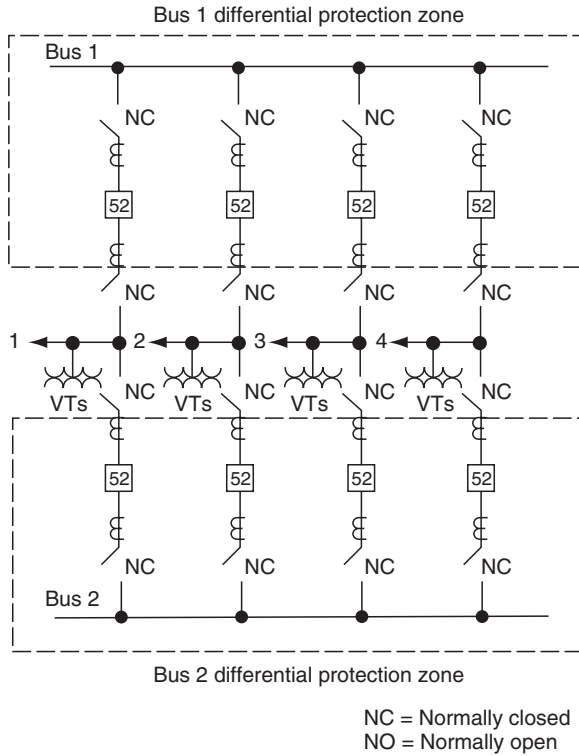

FIGURE 10.5 Typical four-circuit double breaker–double bus and the bus differential protection zones.

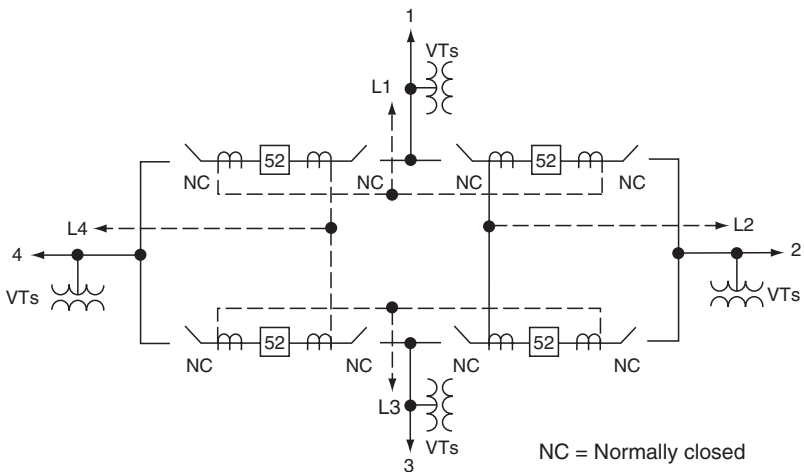

FIGURE 10.6 Typical four-circuit ring bus. Differential protection is not applicable. Bus sections are protected as part of the lines or connected equipment, as shown dotted.

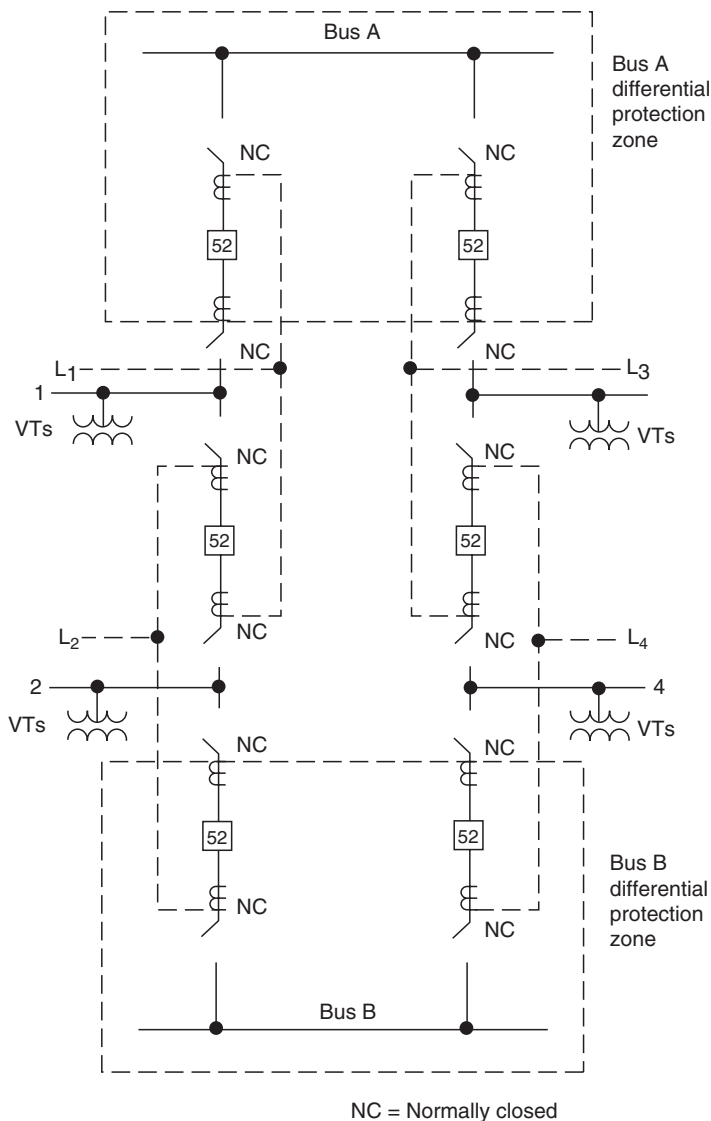

FIGURE 10.7 Typical four-circuit breaker-and-a-half bus and the bus differential protection zones. The mid-bus sections are protected as part of the lines or connected equipment, as shown dotted.

are available on these types of relays. A setting group can be dedicated to each circuit and settings applied to specifically match each circuit's needs. The required setting group can be enabled automatically by switch position contacts that identify the specific circuit that is connected to the transfer bus.

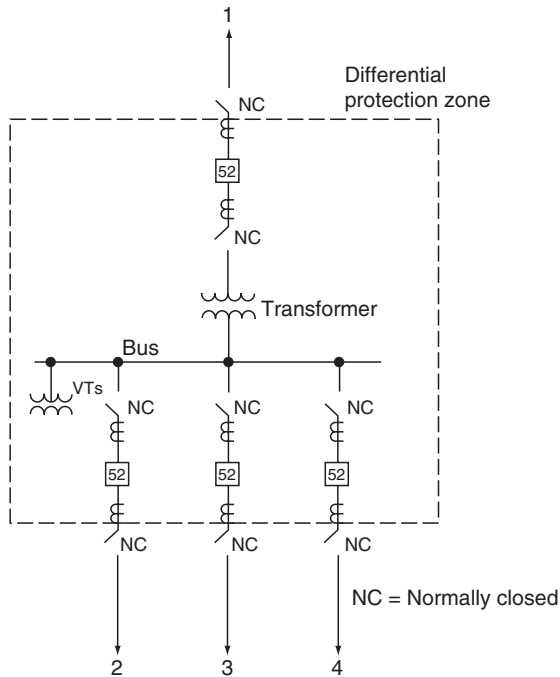

FIGURE 10.8 Typical four-circuit single breaker bus and transformer with combined bus-transformer differential protection zone.

One set of VTs on the bus can supply voltage to all the protection for the several circuits.

10.5 SINGLE BREAKER–DOUBLE BUS

This arrangement (Figure 10.4) provides high flexibility for system operation. Any line can be operated from either of the buses, the buses can be operated together, as shown, or independently, and one bus can be used as a transfer bus if a line breaker is out of service. The disadvantage is that it requires complicated switching of the protection: for both the bus differential and line protection. Two differential zones for the buses are required. In Figure 10.4, lines 1 and 2 are shown connected to bus 1, with lines 3 and 4 connected to bus 2. For this operation, the differential zones are outlined: dashed for bus 1, and dash-dot for bus 2.

As for the previous bus arrangement (see Figure 10.3), the bus tie protection must be adaptable for the protection of any of the lines when 52T is substituted for any of the line circuit breakers. When a line breaker is bypassed and the bus tie (52T) breaker substituted, using one bus as a transfer bus, the differential protection on that bus must be removed from service.

Faults on either buses or associated circuits require tripping of all circuits connected to the bus at that time. Faults in the bus tie breaker (52T) must trip both buses and all circuits. VTs for protection are required for each bus, as shown. However, line-side VTs are preferable to avoid switching if voltage is required for line protection.

This bus arrangement is not in wide use in the United States, fundamentally because of the protection complications. Modern microprocessor relays need to be applied to reduce these complications by using the flexibility of such relays and the programmable logic, which are provided for such devices.

10.6 DOUBLE BREAKER–DOUBLE BUS

This is a very flexible arrangement that requires two circuit breakers per circuit (Figure 10.5). Each bus is protected by a separate differential, with zones as illustrated. The line protection operates from paralleled CTs, and this provides protection for the bus area between the two zones overlapping the two breakers. Line protection operates to trip both breakers.

With all disconnected switches normally closed (NC), as shown, a fault on either of the buses does not interrupt service on the lines. All switching is done with breakers, and either bus can be removed for maintenance. Line-side voltage, either VTs or CCVTs, is necessary if required by the line protection.

10.7 RING BUS

The ring bus arrangement (Figure 10.6) has become quite common, particularly for higher voltages. High flexibility with a minimum of breakers is obtained. Each breaker serves two lines and must be opened for faults on either line. The bus section between the breakers becomes part of the line, so that bus protection is not applicable or required. The interconnection of the CTs for protection of each line is shown dashed in Figure 10.6, and line faults must trip two breakers. If the ring is open for any reason, a fault on a line may separate the other lines and the bus. This can result in a significant disruption to the power system network, which must be taken into account from a system operation and protection coordination standpoint. Line protection voltage, if required, is obtained from VTs or, more commonly, at the higher voltages by CCVTs connected to each line.

10.8 BREAKER-AND-HALF BUS

This arrangement (Figure 10.7) provides more operating flexibility, but requires more circuit breakers than the ring bus. This type is also widely used, especially for larger multicircuit, higher-voltage systems. Two operating buses each have separate differential protection. Each line section is supplied by both buses through two circuit breakers. The center circuit breaker serves both lines; hence, the half designation is given to the center circuit.

The CT interconnections are shown for each line section as dashed lines in [Figure 10.7](#). Voltage for line relays must use line-side CCVTs or VTs. Line faults trip two breakers, but do not cause loss of service to the other lines if all breakers are normally closed as shown.

10.9 TRANSFORMER–BUS COMBINATION

This is the single breaker–single bus of [Figure 10.1](#), with a transformer bank directly connected to the bus as shown in [Figure 10.8](#). The advantage is the cost saving of the circuit breaker between the transformer and the bus. It is practical for small stations, such as distribution, where there is only one transformer to supply several circuits. Here a fault either in the transformer or on the bus requires that all service be interrupted, with or without the intervening breaker.

The differential zone includes both the bus and the transformer (dashed lines). In these applications transformer differential relays must be used. The application and the setting for these are presented in [Chapter 9](#).

10.10 GENERAL SUMMARY OF BUSES

[Table 10.1](#) and [Table 10.2](#) provide a brief summary of several bus arrangements outlined in the foregoing. The far-right column of [Table 10.2](#) indicates the tripping requirements, in the event that one of the breakers fails to clear a fault on a circuit connecting to the bus. This could result either from the malfunction of the protective system or from the breaker failing to open properly. Local breaker failure-backup protection is assumed, and this is discussed in [Chapter 12](#).

10.11 DIFFERENTIAL PROTECTION FOR BUSES

Complete differential protection requires that all circuits connected to the bus be involved, because it compares the total current entering the zone with the total current leaving the zone. Except for a two-circuit bus, this means comparisons between several CTs that are operating at different energy levels and often with different characteristics. The most critical condition is the external fault just outside the differential zone. The CTs on this faulted circuit receive the sum of all the current from the other circuits. Thus, it must reproduce a potential high-current magnitude with sufficient accuracy to match the other CT secondary currents and avoid misoperation. Therefore, CT performance is important. The relays and CTs are both important members of a “team” to provide fast and sensitive tripping for all internal faults, at the same time, restrain for all faults outside the differential zone. Two major techniques are in use to avoid possible unequal CT performance problems: (1) multirestraint

TABLE 10.1
General Summary of Advantages and Disadvantages

Figure No.	Arrangement	Advantages	Disadvantages
10.1	Single breaker, single bus	<ol style="list-style-type: none"> 1. Basic, simple, economical 2. One bus voltage for all circuits 	<ol style="list-style-type: none"> 1. No operating flexibility 2. All breakers opened for bus fault 3. Circuit removed for maintenance or problems
10.2	Double bus with bus tie	<ol style="list-style-type: none"> 1. Two power sources to feed two buses 2. One source lost, load transferred 3. One bus out, partial service available 	<ol style="list-style-type: none"> 1. Circuit removed for maintenance or problems 2. Bus tie breaker fault trips both buses 3. Voltage required on each bus
10.3	Main and transfer bus	<ol style="list-style-type: none"> 1. One differential zone 2. Only one circuit transferred 3. Breaker, relays transferred for maintenance, etc. 4. Voltage only on main bus 	<ol style="list-style-type: none"> 1. Bus tie breaker protection suitable for each circuit 2. Bus fault trips all breakers 3. Potential for error 4. Bus tie protection adaptable for all circuits
10.4	Single breaker, double bus	<ol style="list-style-type: none"> 1. High flexibility 2. Any line operated from either bus 3. One bus available as a transfer bus 	<ol style="list-style-type: none"> 1. Complicated (undesirable) switching of protection 2. Bus tie breaker protection suitable for each circuit 3. With line breaker bypassed differential removed from one bus 4. Bus tie breaker fault trips all breakers 5. Voltage required for each bus

(continued)

TABLE 10.1 (continued)
General Summary of Advantages and Disadvantages

Figure No.	Arrangement	Advantages	Disadvantages
10.5	Double breaker, double bus	<ol style="list-style-type: none"> 1. Very high flexibility 2. Overlapping protection zones 3. Bus fault does not interrupt service 4. All switching by breakers 5. Either bus can be removed 	<ol style="list-style-type: none"> 1. Protection in service during breaker maintenance 2. Two breakers per line 3. Line protection from two CTs 4. Requires line side voltage 5. Two breakers trip for line faults
10.6	Ring bus	<ol style="list-style-type: none"> 1. High flexibility 2. Minimum breakers 3. Bus section part of line, no bus differentials 	<ol style="list-style-type: none"> 1. Requires line side voltage 2. Relays in service during breaker maintenance 3. Line faults trip two breakers 4. Local backup not applicable 5. Open ring and subsequent fault may result in undesired system separation
10.7	Breaker and a half bus	<ol style="list-style-type: none"> 1. More operating flexibility 2. Bus section part of lines 	<ol style="list-style-type: none"> 1. Required more breakers 2. Center breaker serves two lines 3. Requires line side voltage 4. Two bus differential zones 5. Local backup not applicable 6. Line faults trip two breakers
10.8	Bus and transformer	<ol style="list-style-type: none"> 1. Saves breaker between bus and transformer 	<ol style="list-style-type: none"> 1. Transformer and bus differential combined. Fault location by inspection

TABLE 10.2
General Summary of System Buses

Bus Type	Fig. No.	Bus sect.	Required for One Line		Required for Each Added Line		Total Four Lines		Three-Phase Voltage Supply for Line Relays	Breaker Failure: Local Backup Requires Tripping ^a
			Breakers	Disconnects	Breakers	Disconnects	Breakers	Disconnects		
Single bus—single breaker	10.1	1	1	2	1	2	4	3	1 on bus	All breakers on bus
Single buses with bus tie	10.2	2	For two-line minimum		1	2	5	10	On each bus	All breakers on bus ^b
Main and transfer bus	10.3	2	3	6	1	3	5	14	1 on main bus	All breakers on bus
			3	5						
Double bus—single breaker	10.4	2	2	7	1	5	5	22	1 on each bus ^c	All breakers on bus ^b
Double bus—double breaker	10.5	2	2	4	2	4	8	16	On each line	All breakers on bus
Ring bus	10.6	0	For two-line minimum		1	2	4	8	On each line	Adjacent breaker and remote line terminal
Breaker and a half	10.7	2	For two-line minimum		Each two lines		6	12	On each line	All breakers on bus; for center breaker, adjacent breaker and remote line terminal
			2	4	3	6				

^aIn addition, the remote terminal of the stuck breaker must be opened by relay action at that terminal or by transfer tripping.

^bFailure of the bus tie breaker requires tripping all circuits on both buses.

^cLine voltage preferred to avoid voltage transfer as lines are switched to a different bus.

current and (2) high-impedance voltage. A third system employs air-core transformers to avoid the iron-core excitation and saturation problems. All are in practical service. They exist with various features, depending on the design. Each feature has specific application rules. These should be followed carefully, for they have been developed to overcome the inherent deficiencies of conventional CTs on both symmetrical and asymmetrical fault currents.

10.11.1 MULTIRESTRAINT CURRENT DIFFERENTIAL

Multirestraint current differential is the most versatile method for general application using conventional current transformers, but in general, is more difficult to apply. However, each manufacturer has developed application connections and criteria that simplify the process. Multirestraint relays are used with a restraint winding connected to each circuit that is a major source of fault current. Feeders and circuits with low-fault current contribution may be paralleled. The fundamentals, discussed in [Section 9.5](#), are applicable in this context. All CTs are connected in wye and to the restraint windings because there are no phase-shift problems with buses except for the example shown in [Figure 10.8](#).

These schemes are designed to restrain correctly for heavy faults just outside the differential zone, with maximum offset current as long as the CTs do not saturate for the flow of maximum symmetrical current. This can be accomplished by CT ratio selection and by keeping the secondary burden low. Thus, it is important and recommended that no other device be connected in the differential circuits. The restraint windings of the differential relays normally have quite low impedance; consequently, the major burden encountered is often that of the leads connecting the CTs to the relays. This can be kept low by use of large wire, which is also desirable to minimize physical damage. Accidental breakage or an opening in the differential circuit can result in incorrect operation and loss of a critical part of the power system.

Multirestraint bus differential relays do not have ratio taps. These are not required in most applications, because a common CT ratio can be normally obtained among the several bus CTs. Otherwise, auxiliary CTs are required for those that do not match. When these are used, it is suggested that they step down the current if possible. This reduces their secondary burden, as discussed in [Chapter 5](#).

The relays exist with up to six restraint circuits, and can have either fixed or variable restraint characteristics. Typical sensitivities for internal faults are on the order of 0.15 A, with operating times of 50–100 msec.

10.11.2 HIGH-IMPEDANCE VOLTAGE DIFFERENTIAL

This scheme loads the CTs with a high impedance to force the error differential current through the CTs instead of the relay-operating coil. The basic

principles are illustrated in Figure 10.9. For an external fault, the maximum voltage V_R across the differential relay Z_R will occur if the CT on the faulted circuit (1) is completely saturated and the other CTs (2 and 3) do not saturate. This is the worst case, because in practice all CTs may not saturate on light external faults or will have varying degrees of saturation for the heavy faults. An empirical margin with a safety factor is provided by the manufacturer to modify this maximum voltage calculation for setting the relay. This calculation is made for both the maximum symmetrical three-phase and phase-to-ground faults. The fault currents are different, and the lead resistance R_L (maximum for the various circuits) is R_L for three-phase faults and $2R_L$ for phase-to-ground faults.

For internal bus faults, as shown in Figure 10.9, the high-impedance Z_R of the bus differential relay forces most of the secondary current through the CT-exciting impedances. Thus, V_R will be high to operate the relay, and is essentially the open-circuit voltage of the CTs. A varistor or similar protective device across Z_R provides circuit protection by limiting the voltages to a safe level. A tuned circuit provides maximum sensitivity at rated system

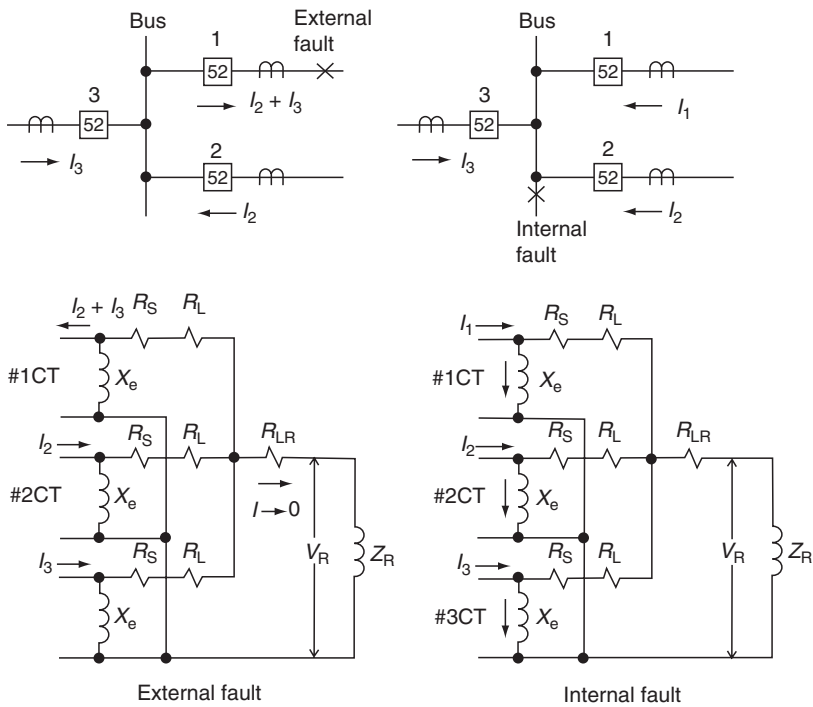

FIGURE 10.9 Operating principles of the high-impedance voltage bus differential system.

frequency, and filters out the DC transient components. The impedance between the junction and the relay R_{LR} is negligible compared to the high value of the relay Z_R .

The scheme requires that the total resistance of the CTs and leads to the junction point ($R_S + R_L$) be kept low. Thus, bushing or toroidal wound CTs, where their secondary impedance is very low, can be used, and they should be interconnected together as near the CT locations as possible, preferably equidistant, so that several R_L values are essentially equal and low.

All CTs should have the same ratio and operate on the full winding. Operating at CT taps is not recommended, but if necessary, the windings between the taps must be completely distributed, and the unused end must be well insulated to avoid high-voltage breakdown from the autotransformer effect. Auxiliary CTs are not recommended. If they are required, a detailed analysis or special relays may be applicable. One type of relay employs added restraint circuits for applications with widely diverse CTs.

The several limitations outlined are not too difficult to meet with modern CTs and proper bus design, so this is a very effective and widely used bus protection system. Typical operating times are in the order of 20–30 msec, and if a supplementary instantaneous unit is used for high-current internal faults, times of 8–16 msec are available.

10.11.3 AIR-CORE TRANSFORMER DIFFERENTIAL

The major problem in differential schemes results because of the CT iron, which requires exciting current and saturates at high fault currents. By elimination of the CT iron, this problem does not exist, and a simple, fast, reliable bus differential system results. This is known as the linear coupler differential scheme, and several of these are in service. Such schemes have not become popular primarily because existing and conventional iron-core CTs cannot be used in these schemes and the linear couplers cannot be used for any other applications.

The linear coupler in appearance is the same as conventional iron-core CTs and can be mounted on a bushing or can be connected as a wound-type CT in the primary circuit. It operates as an air-core mutual reactor where

$$V_{\text{Sec}} = I_{\text{Pri}} M V, \quad (10.1)$$

where M has been designed to be 0.005Ω at 60 Hz. Thus, a secondary voltage of 5 V is induced for 1000-primary amperes. The linear coupler secondaries for each circuit on the bus are all connected in series and to a sensitive relay unit. For an external fault or load, the sum of the voltage for all current flowing into the bus is equal and opposite to the voltage that is developed by the current flowing out of the bus. Thus, the voltage across the relay is essentially zero for no operation.

For an internal fault, with all current flowing into the bus, the linear coupler secondary voltages add to produce an operating voltage. Thus, the relay-operating current (I_R) is

$$I_R = \frac{V_{Sec}}{Z_R + Z_C}, \quad (10.2)$$

where Z_R is the relay coil impedance and Z_C is the linear coupler secondary impedance. Typical values of Z_C are about 2–20 Ω for Z_R . Lead impedance is not significant with these values. The relays operate from 2 to 50 mA for high sensitivity. Typical times are 10 msec and less.

The system is quite flexible because the linear coupler secondaries do not have to be shorted if open-circuited, and circuits can be added or subtracted with minimum problems. Changing the number of circuits affects the value of the Z_C sum, which is basically offset by a corresponding change in the V_{Sec} sum.

If the primary circuit is subject to high frequencies, such as those that occur with large capacitors or back-to-back switching of capacitors, secondary lightning arrestors may be required. Linear couplers transform all frequencies very efficiently. In linear coupler schemes, it is important that good connections be maintained in the control circuitry to prevent excessive voltage drops across contact resistance, which can affect the performance of such schemes.

10.11.4 MODERATE HIGH-IMPEDANCE DIFFERENTIAL

This is a combination of the percentage and high-impedance voltage differential techniques that provides low-energy, high-speed bus protection. It can be applied with CTs of varying saturation characteristics and ratios and can be used with magneto-optic current transducers. When used with 5 A CTs, special auxiliary CTs are required for each circuit. Diodes separate the CTs' positive and negative half-cycles, developing a unidirectional sum current to provide percentage differential restraint.

For internal faults, all currents into the fault provide a high voltage, similar to that produced in the high-impedance differential scheme for operation. For external faults, when the currents into the bus equal the current out, a low-voltage exists to inhibit operation.

Correct performance is assured where CTs may saturate because it takes about 2–3 msec of each half-cycle for saturation to occur, as illustrated in [Figure 5.15](#). This provides ample time for correct performance.

10.12 OTHER BUS DIFFERENTIAL SYSTEMS

Several other schemes exist, but are in limited use. These are the time-overcurrent, directional comparison, and partial differential systems.

10.12.1 TIME-OVERCURRENT DIFFERENTIAL

In this, the secondaries of all the current transformers are paralleled and connected to an inverse-time-overcurrent (51) relay. There is no restraint, so the relay must be set above the maximum CT's magnetizing difference current for the external fault.

The inverse characteristic, which provides extended times for low-current magnitudes, is an advantage to override unequal CT saturation, particularly on the DC component. Thus, the DC time constant should be short for these applications. Typical operating times for these schemes are 15–20 cycles (60 Hz base) for internal faults, where the total fault current adds for relay operation. This provides a relatively inexpensive but slow differential, and one that is difficult to set with security except through long experience. It is used only for small, low-voltage buses.

10.12.2 DIRECTIONAL COMPARISON DIFFERENTIAL

A directional-sensing unit, as described in [Chapter 3](#), is connected to each bus circuit “looking into” the bus, with the trip contacts in series. For normal operation, one or more contacts are opened by the load passing through the bus. For internal faults, all contacts should be close to trip the bus. Normally closed contacts are necessary for feeder circuits with no feed to the fault.

The major advantage is its nearly complete independence of CT performance, characteristic, and ratio. The disadvantages are a relatively high cost (relays required for each circuit), a need for voltage or reference source, and the difficulties for contacts in series to coordinate. It has not been in general use in recent years.

10.12.3 PARTIAL DIFFERENTIAL

The partial differential scheme is used frequently to provide protection for buses in industrial and lower-voltage distribution substations. It is applicable where there are feeder circuits that (1) supply negligible current to bus faults and (2) do not have adequate or suitable CTs for a complete differential application. Good examples are feeders that supply only static or induction motor loads and when there is a great diversity in their power ratings. A typical bus of this type is shown in [Figure 10.10](#). The CTs of the fault-source circuits are paralleled and connected to inverse-time-overcurrent (51) relays. As illustrated in [Figure 10.10b](#) and [Figure 10.10d](#), negligible current flows in the 51 relays for external faults in the sources. The total fault current is available to operate the relays for bus and for faults out on the feeders. This requires that the 51 relays be time-coordinated, with the protection on all the feeders not included in the differential. The use of an inverse relay and this scheme provides a good compromise for low-voltage substation buses. Three-phase connections are included in [Figure 9.26](#).

If current-limiting reactors are used in the feeder circuits, distance-type relays (21) can be substituted for the 51 relays. The 21 relays are set into, but not through, the lowest reactor impedance. This does not require selective settings with the feeder protection, and thus avoids the time delay necessary with the 51 relays to provide fast and sensitive bus protection. It does, however, require bus voltage for the distance relays.

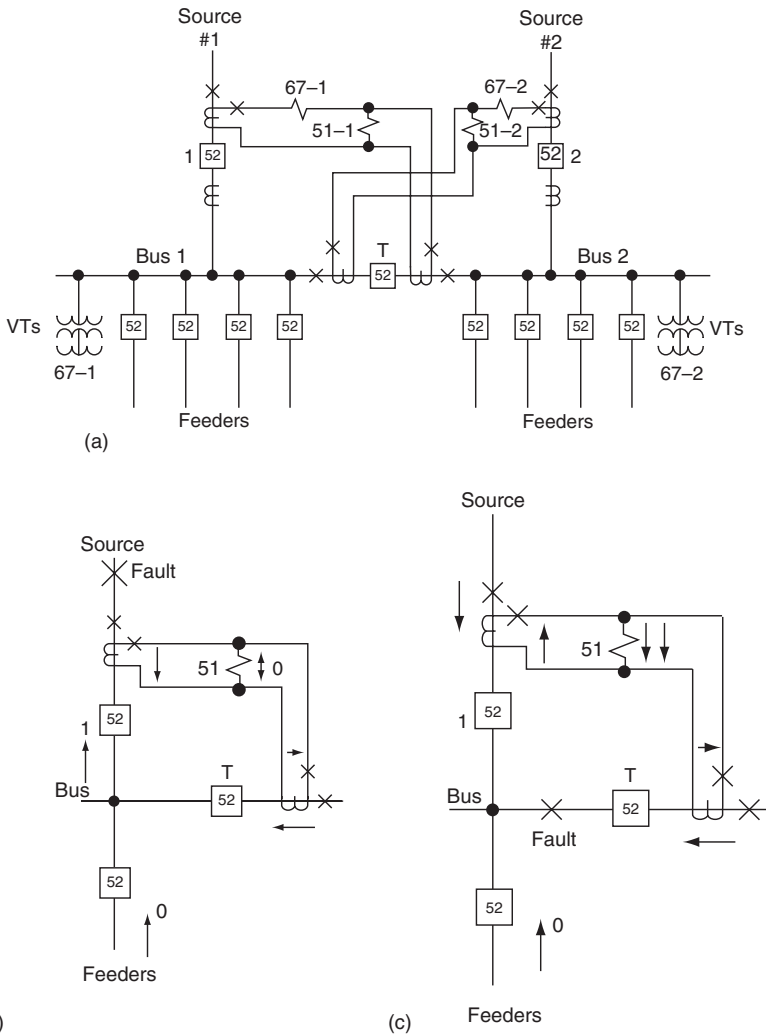

FIGURE 10.10 Partial differential bus and feeder backup protection: (a) Single-line diagram for a typical bus arrangement. (b) Operation for source-side faults. (c) Operation for bus and feeder faults. (Continued on next page.)

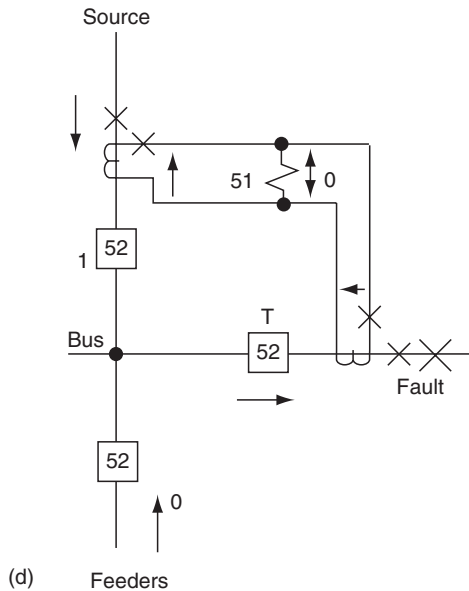

FIGURE 10.10 (continued) (d) Operation for adjacent bus faults.

10.12.4 SHORT TIME DELAY SCHEME—INSTANTANEOUS BLOCKING

The short time delay instantaneous blocking scheme is becoming increasingly more popular for use on lower-voltage buses that contain circuits supplying radial load. This scheme is connected in a similar manner to the partial differential scheme that was previously described, but uses an instantaneous relay with a short time delay to initiate tripping rather than a time-overcurrent relay. This scheme requires the use of instantaneous relays installed on each of the circuits that are connected to the bus, which supplies radial load. Operation of any of these instantaneous relays on the load circuits blocks tripping of the bus protection scheme. The circuit instantaneous relays must be set lower than the tripping instantaneous relays. When the instantaneous tripping relays operate, a trip of the bus is initiated after a brief delay, if none of the instantaneous blocking relays on the circuits have been activated. The tripping time delay setting should be as fast as possible while allowing a safe delay for blocking, which has to be initiated for external faults. A time delay in the six-cycle area would be appropriate in most cases. In some cases, instantaneous relays used for circuit protection may be used for a dual function of providing blocking in the bus protection scheme. In most cases, however, setting requirements will not be compatible; and dedicated relays are required to provide the blocking function.

The short time delay bus scheme has not been used extensively in the past because of the additional cost associated with the instantaneous blocking

relays and the complications associated with the wiring that is needed to supply the blocking logic. With utilization of microprocessor based relays and digital communication systems within substations, these disadvantages are greatly reduced. Microprocessor relays are available with multiple elements for providing instantaneous overcurrent monitoring without a significant impact on the cost. Digital communication systems provide flexibility for developing and changing control logic as required.

10.13 GROUND-FAULT BUS

The bus supports and the substation equipment are insulated from the ground and are all connected together to be grounded at one point through an over-current relay. A ground fault that involves this interconnection passes current through the relay to trip the respective protected area. A separate fault detector is used to supervise tripping for added security. This relay operates on system zero-sequence current or voltage. This scheme basically is not used in the United States because of relatively higher cost and difficulties of construction and in protecting the personnel.

10.14 PROTECTION SUMMARY

Differential protection should be considered and applied wherever possible for all buses as the primary protection. Although bus faults are relatively infrequent, they can be very disruptive to a power system; therefore, fast, sensitive protection, as available through the various differential systems, is recommended. The most probable causes of bus faults are animals, wind-blown objects, and insulation failures (natural or gunshot). Lighting may result in bus faults, but stations and substations generally are well shielded and protected against lightning. The protection applied to the several circuits connected to the bus generally provides the backup protection for the bus, or the primary protection where bus differentials are not or can not be applied.

10.15 BUS PROTECTION—PRACTICAL CONSIDERATIONS

The use of high-impedance differential schemes for protection of high-voltage buses has been the application of choice for many utilities in the United States. This is probably due to its straightforward approach for developing related settings and its excellent performance record. A variety of protective schemes are used for lower-voltage buses depending on the overall design of the substation and the protection philosophy of the associated utility.

As noted, bus faults can be highly disruptive to power systems and often result in associated equipment damage because of the high level of fault energy that is often available at bus locations. Practices that emphasize tactics to prevent bus failures can be highly rewarding and cost effective. As major

causes of bus faults are insulation failures caused by contamination, wear and tear, small animal contacts, and foreign objects such as bird nests, good designs (i.e., application of animal guards, etc.), and maintenance practices can go a long way in preventing bus faults from occurring.

Experience over a long period has shown that the performance of bus protective schemes is highly reliable. To a large extent, this is perhaps because of the fact that the bus schemes are designed to operate properly, with a margin of safety and for a worst-case, close-in, external fault. The probability of an actual fault occurring that matches this worst-case assumption is very low. Furthermore, additional safety margin is available within the scheme for the vast majority of external faults that challenge the security of the bus protection.

BIBLIOGRAPHY

See the Bibliography at the end of [Chapter 1](#) for additional information.

ANSI/IEEE Standard C37.97, Guide for Protective Relay Applications to Power Buses, IEEE Service Center.

Udren, E.A., Cease, T.W., Johnston, P.M., and Faber, K., Bus differential protection with a combination of CTs and magneto-optic current transducers, 49th Protective Relay Engineers Conference, Georgia Institute of Technology, Atlanta, GA, May 3–5, 1995.

11 Motor Protection

11.1 INTRODUCTION

The protection of motors varies considerably and is generally less standardized than the protection of the other apparatus or parts of the power system. This results from the wide variety of sizes, types, and applications of motors. The protection is principally based on the importance of the motor, which usually is closely related to the size. This chapter deals with motors and the protection applied directly to them. Backup often associated with the connecting circuits is discussed in [Chapter 9](#). The present discussion is for motors that are switched by a circuit breaker, contactors, or starters, and for which the protection is separate from these devices and from the motor. Essentially, this covers motors at the 480 to 600 V level and higher. Not covered specifically or directly are motors for which the protection is built into the motor or starter, or for which fuses are the only protection.

11.2 POTENTIAL MOTOR HAZARDS

The potential hazards normally considered are

1. Faults: phase or ground
2. Thermal damage from
 - a. Overload (continuous or intermittent)
 - b. Locked rotor (failure to start or jamming)
3. Abnormal conditions
 - a. Unbalanced operation
 - b. Undervoltage and overvoltage
 - c. Reversed phases
 - d. High-speed reclosing (reenergizing while still running)
 - e. Unusual ambient or environmental conditions (cold, hot, and damp)
 - f. Incomplete starting sequence

These are for induction motors, which represent the large majority of all motors in service. For synchronous motors, additional hazards are

4. Loss of excitation (loss of field)
5. Out-of-step operation (operation out of synchronism)
6. Synchronizing out of phase

These can be reclassified relative to their origins:

- A. Motor-induced
 1. Insulation failure (within motor and associated wiring)
 2. Bearing failure
 3. Mechanical failures
 4. Synchronous motors: loss of field
- B. Load-induced
 1. Overload (and underload)
 2. Jamming
 3. High inertia (Wk^2)
- C. Environment-induced
 1. High ambient temperature
 2. High contaminant level: blocked ventilation
 3. Cold, damp ambient temperature
- D. Source- or system-induced
 1. Phase failure (open phase or phases)
 2. Overvoltage
 3. Undervoltage
 4. Phase reversal
 5. Out-of-step condition resulting from system disturbance
- E. Operation- and application-induced
 1. Synchronizing, closing, or reclosing out of phase
 2. High duty cycle
 3. Jogging
 4. Rapid or plug reversing

11.3 MOTOR CHARACTERISTICS INVOLVED IN PROTECTION

The primary motor characteristics available and involved in the protection are

1. Starting-current curves
2. Thermal capability curve, which should include the permissible locked-rotor thermal limit
3. The K constant (R_{r2}/R_{r1})

These characteristics normally are obtained from the motor manufacturer and are basic for the application of protection. Typical curves are illustrated in [Figure 11.1](#). The maximum starting-current curve is at the rated voltage. Currents for lower voltages exist to the left, with the knee at a higher time level.

The thermal limits are three different curves, which often approximately blend together to a general curve, such as that shown. Thermal limits are relative indeterminate zones that engineers desire to have represented by a specific curve.

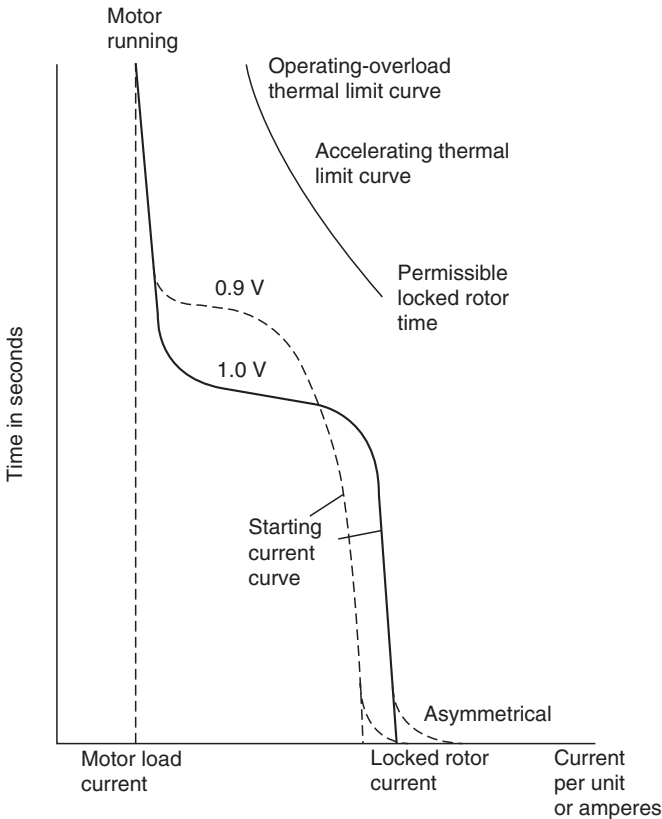

FIGURE 11.1 Typical induction motor characteristics.

1. The higher-current portion indicates the permissible locked rotor times. This is the time the rotor can remain stalled after the motor has been energized before thermal damage occurs in the rotor bars, rotor end rings, or in the stator, whichever is the limit for a particular design.

In very large motors this locked-rotor thermal limit can be lesser than the starting time, so these motors must start rotating instantly to avoid thermal damage. This curve is from locked-rotor current at full voltage to that current at the minimum permissible starting voltage.

2. The accelerating thermal limit curve from locked-rotor current to the motor breakdown torque current, which is about 75% speed.
3. The operating or running thermal limit curve, which represents the motor overload capacity during emergency operation.

11.4 INDUCTION MOTOR EQUIVALENT CIRCUIT

As an aid in the protection and for protection analysis, the equivalent motor diagram can be reduced as shown in Figure 11.2. The typical values for induction motors in per unit on the motor kVA or kV, as shown in Figure 11.2b, are R_s and $R_r = 0.01$ pu, $jX_m = j3.0$ pu, and $jX = jX''_d = 0.15$ pu, and from these, the typical locked rotor or starting current is

$$I_{\text{starting}} = \frac{1}{jX''_d} = \frac{1}{0.15} = 6.67 \text{ pu.} \quad (11.1)$$

This is the symmetrical value; the asymmetrical current is higher (see Figure 11.1).

Because the shunt jX_m is high relative to the other impedances, the equivalent at the motor input reduces with the foregoing typical values to

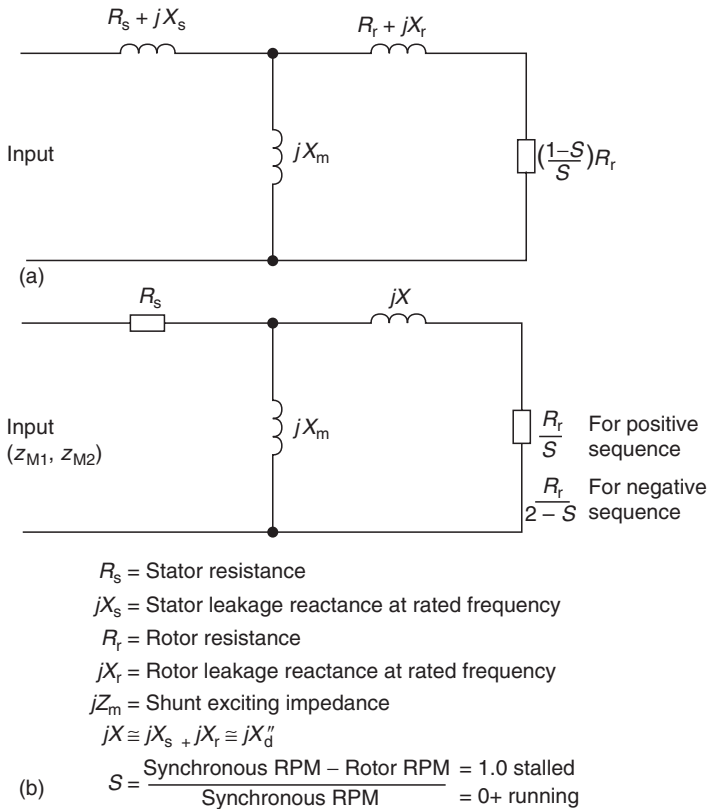

FIGURE 11.2 Equivalent-circuit diagrams for induction motors: (a) equivalent diagram for an induction motor; (b) simplified equivalent induction motor diagram.

$$Z_{M1} = Z_{M2} = 0.144 \angle 82.39^\circ. \quad (11.2)$$

or practically equal to $jX_d'' = 0.15$ pu, as commonly used for a stalled motor ($S = 1.0$). If the motor is running ($S = 0.01$), the foregoing values give

$$Z_{M1} = 0.927 \angle 25.87^\circ \quad \text{and} \quad Z_{M2} = 0.144 \angle 84.19^\circ \text{ pu.} \quad (11.3)$$

Thus, practically,

$$Z_{M1} = 0.9 \text{ to } 1.0 \text{ pu} \quad \text{and} \quad Z_{M2} = 0.15 \text{ pu.} \quad (11.4)$$

From stalled to running, the positive-sequence impedance changes from approximately 0.15 to 0.9 or 1.0 pu, whereas the negative-sequence impedance remains essentially the same, at approximately 0.15 pu. Moreover, these are based on the rated motor kVA, which is approximately equal to the motor horsepower (hp). These values will vary with each individual motor, but these typical values are close and quite useful if specific data are not available.

11.5 GENERAL MOTOR PROTECTION

Protection for motors exists in many forms: a variety of designs and either packaged individually or in different combinations. Each has its features, which will not be restated or evaluated in this chapter. The fundamentals and basic aim should be to permit the motor to operate up to, but not to exceed, its thermal and mechanical limits for overloads and abnormal operation conditions and, to provide maximum sensitivity for faults. These can usually be achieved in general terms as follows.

11.6 PHASE-FAULT PROTECTION

Instantaneous nondirectional overcurrent relays (50,51) can be used to protect induction motors. Faults generally provide current greater than the locked-rotor starting current, except for turn-to-turn faults. Considerable current can flow between turns, but unfortunately, very little evidence of this is available at the motor terminals until it develops into other types, phase-to-ground or phase-to-phase.

The motor is the end device in the electrical system, so instantaneous relays can be used. There is no coordination problem. The induction motor backfeed to system faults is relatively small ($1/X_d'' + \text{offset}$) and decays rapidly in a few cycles; therefore, nondirectional relays can be applied. The CT ratios supplying these relays should be selected such that the maximum motor current provides between 4 A and 5 A secondary current.

Phase-instantaneous relays should be set well above the asymmetrical locked rotor and well below the minimum fault current. This can be equated where I_{LR} , the locked rotor symmetrical is

$$I_{LR} = \frac{1}{X_{1S} + X_d''}, \quad (11.5)$$

where X_{1S} is the total reactance (impedance) of the power system or source to the motor. This equation is similar to Equation 11.1, where the maximum starting or locked-rotor current is with a very large or infinite source, so X_{1S} approaches zero. A fault at the motor is

$$I_{3\phi} = \frac{1}{X_{1S}} \quad (11.6)$$

and for a phase-to-phase fault with $X_{1S} = X_{2S}$,

$$I_{\phi\phi} = 0.866 I_{3\phi} = \frac{0.866}{X_{1S}}. \quad (11.7)$$

If P_R is the ratio of the relay pickup (I_{PU}) to locked-rotor current,

$$P_R = \frac{I_{PU}}{I_{LR}}. \quad (11.8)$$

Typically, P_R should be 1.6–2.0 or greater.

If P_F is the ratio of the minimum fault-to-relay pickup current,

$$P_F = \frac{I_{\phi\phi \text{ min}}}{I_{PU}}. \quad (11.9)$$

Desirably, P_F should be 2–3 or greater. From Equation 11.9 and Equation 11.8,

$$I_{\phi\phi} = P_F I_{PU} = P_F P_R I_{LR}$$

and

$$\frac{I_{\phi\phi}}{I_{LR}} = P_F P_R \quad \text{or} \quad \frac{I_{3\phi}}{I_{LR}} = 1.155 P_F P_R \quad (11.10)$$

or the three-phase solid fault at the motor should be $1.155 P_F P_R$ or larger for good instantaneous overcurrent protection. If the minimum recommended values of $P_R = 1.6$ and $P_F = 2$, the three-phase fault should be 3.7 times the

locked rotor current. If $P_R = 2$, $P_F = 3$, the three-phase fault should be at least 6.9 times larger than the locked rotor current.

Equating Equation 11.7 and Equation 11.10 and substituting Equation 11.5 yields

$$\begin{aligned} I_{\phi\phi} &= \frac{0.866}{X_{1S}} = \frac{P_F P_R}{X_{1S} + X'_d}, \\ X_{1S} &= \frac{0.866 X''_d}{P_F P_R - 0.866}. \end{aligned} \quad (11.11)$$

Thus, with $P_R = 1.6$, $P_F = 2$,

$$X_{1S} = \frac{0.866 X''_d}{(2 \times 1.6) - 0.866} = 0.371 X''_d$$

and with the standard $X''_d = 0.15$, $X_{1S} = 0.056$ pu, or with $P_R = 2$, $P_F = 3$, and $X''_d = 0.15$, $X_{1S} = 0.025$ pu. This defines the source impedance, which should be as indicated or less for instantaneous overcurrent protection. The per-unit values in the examples are on the motor kVA, kV base, where

$$\text{kVA}_{\text{rated}} = \frac{(\text{horsepower})(0.746)}{(\text{efficiency})(\text{power factor})}. \quad (11.12)$$

In many applications, the source X_{1S} for all practical purposes is the reactance of the supply transformer, which is connected on its primary to a large utility, which is a relatively infinite source. Furthermore, the supply transformer is generally supplying other loads and so is larger than any specific motor; consequently, its reactance on the motor base will tend to be small. This can be illustrated with the example of Figure 9.19, where a 2500 kVA transformer with 5.75% X is shown supplying an 800 A feeder. Suppose that this is a motor: then, 800 A at 480 V equals 665 kVA. At 665 kVA, the transformer reactance X_T is $5.75(665)/2500 = 1.53\%$ or 0.0153 pu. Assuming that X_T is basically equal to X_{1S} , this is well below the 0.025 pu limit derived from Equation 11.11 to provide good instantaneous relay protection.

If the recommended foregoing setting criteria of P_R and P_F cannot be met, or when more sensitive protection might be desired, the instantaneous relay (or a second relay) can be set more sensitively if delayed by a timer. This permits the asymmetrical starting component to decay out. A typical setting recommendation for this is a P_R of 1.1–1.2 with a time delay of 0.10 sec (six cycles at 60 Hz). A similar setting can be used if the applied instantaneous relay is insensitive to the offset component of fault current. Many modern microprocessor based relays are designed to meet this requirement.

If, on loss of voltage, running motors are transferred from a bus to a hot bus, or if high-speed system reclosing reenergizes motors before their residual voltage attains a drop to about 33% rated, very high transients can occur. These currents are very hard on motors unless specifically designed for them. Careful attention must be given to set the relays above this transient if the condition is tolerable. When the foregoing criteria indicate that there is not sufficient margin between locked-rotor and fault current, differential protection is indicated.

11.7 DIFFERENTIAL PROTECTION

Differential protection (87) is preferred. However, for some motors the two ends of the windings may not be available, and differential protection cannot be applied. If both ends of the windings are available, the best differential, in terms of sensitivity, speed, and security, is to pass the conductors of the windings through a flux summation (ring) CT, as shown in Figure 11.3a. These CTs are described in [Chapter 5](#) and also applied for smaller generator

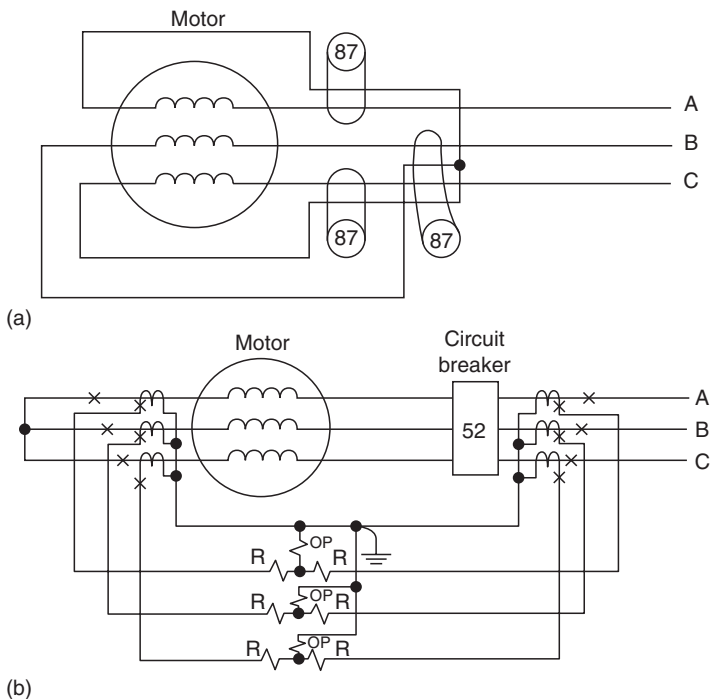

FIGURE 11.3 Differential protection for motors where the neutral leads are available: (a) with flux summation (ring)-type CTs and instantaneous overcurrent relays (50); (b) with conventional-type CTs and differential relays.

protection in [Chapter 8](#). Typical maximum openings or windows in these CTs are about 8 in. in diameter. With a fixed ratio of 50:5 and a sensitive instantaneous overcurrent relay (50), the combination can provide a pickup of nearly 5 A primary current. This is a flux-balancing differential, independent of load and starting current magnitudes and with only one CT per phase, so that matching CT performance does not exist. Internal phase and ground protection is provided within the motor and up to the CT location. Other protection is required for the connections to the circuit breaker, starter, and so on. The limitation is the size of the conductor in relation to the CT opening.

Conventional differential with CTs in the neutral and output leads should be applied where the flux summation type cannot be used. Normally, the two sets of CTs would be of the same type and ratio, so conventional 87 two-restraint differential relays are applicable, as illustrated in [Figure 11.3b](#). With the equal CT ratios, the secondary currents through the relay restraint windings (R) would be essentially the same for all external faults and load and the operating current (OP) would be from a very small value to zero. For motor faults between the two sets of CTs, all of the fault current flows through the (OP) operating winding for high sensitivity to both phase and ground faults. The line-side CTs should be as shown, so that the differential zone includes the circuit breaker, connecting leads, as well as the motor.

11.8 GROUND-FAULT PROTECTION

As for phase protection is concerned, instantaneous overcurrent relays are applied for ground-fault protection (50G, 50N, 51N). Where applicable, the preferred method is to use a flux summation-type current transformer, with the three motor conductors passing through the CT opening. This provides a magnetic summation of the three-phase currents so that the secondary output to the relay is zero-sequence ($3I_0$) current. This is shown in [Figure 11.4a](#). The CT ratio, commonly 50:5, is independent of motor size, whereas the conventional CTs in the phases must be sized to the motor load. The advantage is high sensitivity with good security, but is limited by the conductor size that can be passed through the CT opening. As indicated in the preceding section, typical sensitivity is 5 amperes primary current.

For larger motors and conductors, a ground relay in the neutral must be used as in [Figure 11.4b](#). Although the load influences the CT ratios, the ground relay can be set sensitively and well below motor load. 50N must be set above any “false” residual current that can result from the unequal performance of the three CTs on high, unequal-offset, starting currents. This is difficult to predetermine, but the probability of a problem is very low if the phase burdens are balanced and the CT voltage developed by the maximum-starting current is not more than 75% of the CT accuracy class voltage. A lower 50N relay tap and consequent higher burden may help by forcing all three CTs to saturate more evenly. The resistance in the neutral

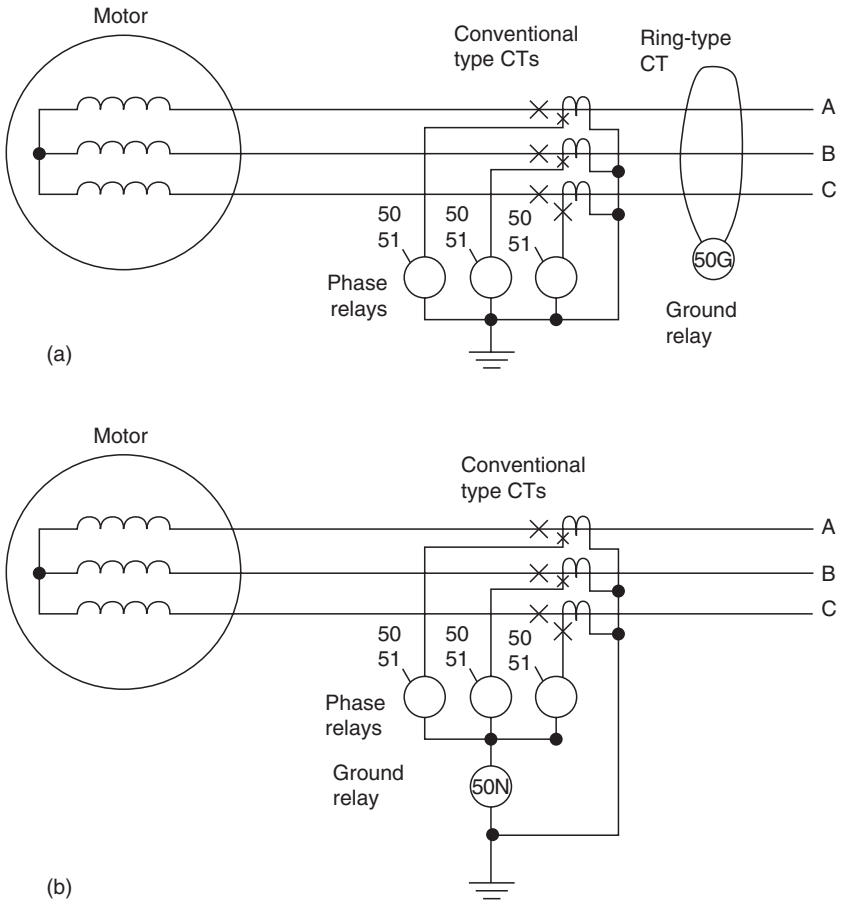

FIGURE 11.4 Ground overcurrent protection for motors: (a) with the three conductors passed through a flux summation-type current transformer; (b) with conventional-type current transformers.

circuit may also be of help. This increased burden, however, should not be large enough to significantly inhibit the relay sensitivity. These latter “fixes” are used generally after trouble is encountered during start-up. Time delay could be used until the offset has decayed, but this delays tripping for actual faults.

With ground-fault limiting, as is common in supply systems for motors, the ground-fault current will be smaller than that for phase faults. If high-resistance grounding is used (see Chapter 7), ground-fault currents will be in the order of 1–10 A primary. The protection as shown in Figure 11.4a can provide reasonable sensitivity for these systems if the ground-fault current is greater than 5 A. Considerably more sensitive protection can be obtained by the application of a product overcurrent relay (32N). This general type was

described in [Section 9.17](#). For this application, a relay with a current coil and a voltage coil is used. It operates on the product of voltage times current and for use in high-resistance, grounded systems; the maximum torque occurs when the current leads the voltage by 45° . The current coil is connected in the neutral of the CTs in place of 50N of [Figure 11.4b](#), and the voltage coil across the grounding resistor and in parallel with 59G in [Figure 7.9](#) or [Figure 7.10](#). The polarity is that the relay will operate when zero-sequence current flows into the motor. As indicated in [Chapter 7](#), the current in high-resistance grounding is low, but the zero-sequence voltage is high. Typical pickup for this product overcurrent relay is about 7–8 mA with 69.5 V. This is well below the ground-fault levels of 1–10 A.

11.9 THERMAL AND LOCKED-ROTOR PROTECTION

This protection involves the application of relays (49–51) to closely match the thermal and locked-rotor curves of [Figure 11.1](#). However, it should be remembered that these motor thermal curves are approximate representations of thermal damage zones for general or normal operation. The relays should operate just before the limits are reached or exceeded.

Over many years, this is accomplished by thermal relays to match the thermal-limit curves, and inverse-time–overcurrent relays for locked-rotor protection. This protection, designed and packaged in various ways, provides very good protection for most motors. Typical applications to the motor characteristics shown in [Figure 11.1](#) are illustrated in [Figure 11.5](#).

Thermal relays are available in several forms:

1. A “replica” type, where the motor-heating characteristics are approximated closely with a bimetallic element within a current heater unit. These operate only on current.
2. Relays operating from exploring coils, usually resistance temperature detectors (RTD), embedded in the motor windings. These operate only on winding temperature, and the detectors are placed in the motor by the designer at the most probable hot spot or danger area. These are common in motors from about 250 hp and higher, but may not be installed in some motors unless specified.
3. Relays that operate on a combination of current and temperature. Care should be exercised to ensure that there are no operating conditions that may not be covered with the combinations, when both are required for relay operation. High current and high temperature normally indicate problems, but high current without measurable high temperature might exist for overheating in the rotor, bearings, drive machine problems, and in the controllers or connections. For these, the combination may provide limited to no protection.

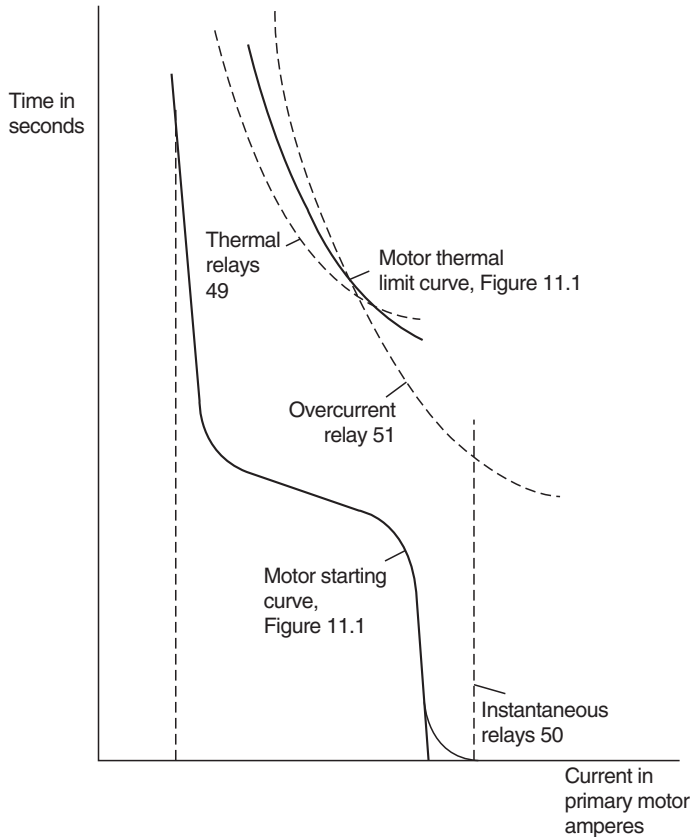

FIGURE 11.5 Typical overload, locked-rotor, and fault protection for a motor.

The comparison of motor-starting and inverse-time–overcurrent relay curves on the same plot, as is commonly done and shown in Figure 11.5, can provide false information. This may occur where the space between the starting current and locked-rotor limit is very narrow, which is usual for very large motors. Often in these situations, it appears possible to set the overcurrent relay so that its characteristic is above the motor start curve and below the locked-rotor limit, only to discover in service that the overcurrent relays operate under normal start.

As a matter of fact, the curves for motor starting and relay operation are two quite different characteristics. The motor-starting curve is a plot of the changing current with time from locked-rotor or starting condition to the motor-load-operating current. The relay characteristic represents the operating times for different constant-current values. With the overcurrent relay normally set at about one-half locked-rotor current or less, it begins operation

at the moment the motor is energized. Unless the starting current drops below the relay pickup before the relay times out, it will initiate undesirable tripping. Relay-operating times for variable current are not directly available from its time characteristic. This is a complex calculation, but manufacturers have developed criteria for individual relays. The microprocessor-type relays provide better protection (see Section 11.16).

11.10 LOCKED-ROTOR PROTECTION FOR LARGE MOTORS (21)

As indicated, the permissible locked-rotor current can be very close or lesser than the starting current. In general, this occurs for very large modern motors. The protection for this can be a zero-speed switch built into the motor. If the motor does not accelerate on energization to open or operate the switch in a prescribed manner, the supply circuit is opened. The concerns with using this type of protection are that the motor could start and lock up at less than full-load speed; the other concern is difficulty of testing and maintenance.

Protection for locked rotors can be obtained by applying a distance relay, as described in Chapter 6. The relay is set looking into the motor (Figure 11.6). The ratio of system voltage and starting current is an impedance, which can be determined and plotted as a vector on the R - X diagram. From a specific value at start, it increases in magnitude and changes phase angle as the motor accelerates. The distance 21 relay is set so that its MHO

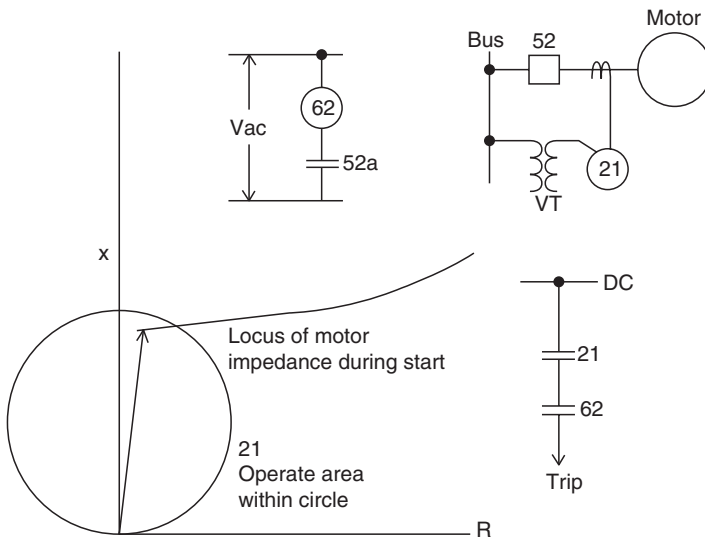

FIGURE 11.6 Locked-rotor protection with a distance (21) relay and timer.

operating circle encloses the locked-rotor impedance vector. When the motor is energized by closing breaker 52, the distance 21 relay operates and the timer 62 is energized. By using an ac-operated timer, variable time with voltage is obtained to match the longer permissible locked-rotor times at lower voltage. The heavy starting current can cause the voltage to drop momentarily during the starting period. If the start is successful, the impedance phasor moves out of the 21 operating circle before the 62 timer contact closes. If the start is unsuccessful, the impedance vector stays in the circle, and when timer 62 operates, the trip is initiated. The timer is set as determined by the permissible locked-rotor time curve from full voltage to about 75% or 80% voltage. This protection does not cover failure to accelerate to full speed, nor to pull out with the rotation still continuing.

11.11 SYSTEM UNBALANCE AND MOTORS

The most common cause of unbalance for three-phase motors is the loss of phase resulting from an open fuse, connector, or conductor. Unbalances in other connected loads can also affect the motor. A voltage unbalance of 3.5% can produce a 25% or greater increase in motor temperature. This results primarily from negative sequence produced by the unbalance. This current produces flux in the motor air gap rotating in the opposite direction to the actual motor direction. The relative effect is essentially double-frequency current in the rotor. Skin effect results in higher resistance, and as outlined in [Section 11.4](#), negative-sequence impedance remains essentially at locked-rotor value. Thus, high current and high resistance compound the heating effect.

The total heating in a motor is proportional to

$$I_1^2 t + K_2^2 t, \quad (11.13)$$

where I_1 and I_2 are the positive- and negative-sequence currents, respectively, in the motor and

$$K = \frac{R_{r2}}{R_{r1}} = \text{conservative estimate as } \frac{175}{I_{LR}^2}, \quad (11.14)$$

where R_{r1} and R_{r2} are the motor rotor positive- and negative-sequence resistances, respectively, I_{LR} the locked-rotor current in per unit. Equation 11.13 shows that there is a high increase in heating from the negative-sequence component.

The symmetrical components network for an open phase is shown in [Figure 11.7](#). This is a simplified circuit showing the total source system as lumped impedances $Z_{S1} = Z_{S2}$. For any specific case, this circuit can be expanded to show more detail of the source or other loads. The supply transformer, for example, can be represented by its reactance (impedance) X_T .

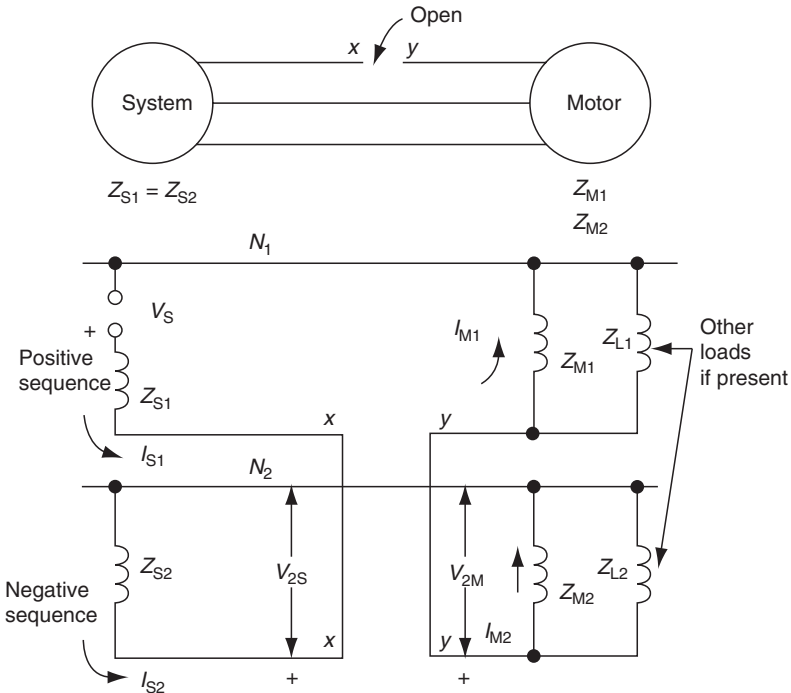

FIGURE 11.7 Simplified symmetrical component representation for an open phase.

For an open phase between the transformer and motor, X_T would be added in series with the source impedances for the equivalent values of Z_{S1} and Z_{S2} . When the open phase is between the system and the transformer, X_T would not be included in the source equivalents, but added in series with the motor impedance. This circuit is for an ungrounded motor, as is the common practice. The zero-sequence network is not involved for one-phase open, unless the systems on either side of the open are both grounded.

The distribution of currents for an open phase using the network of Figure 11.7 is shown in Figure 11.8 for several situations. Typical per unit values of impedances shown are all on the motor kVA base, and are

$$\begin{aligned}
 Z_{S1}Z_{S2} &= 0.05 \angle 90^\circ \text{ pu,} \\
 Z_{L1} &= Z_{L2} = 1.0 \angle 15^\circ \text{ pu for static loads at the motor,} \\
 Z_{M1} &= 0.9 \angle 25^\circ, \\
 Z_{M2} &= 0.15 \angle 85^\circ.
 \end{aligned}
 \tag{11.15}$$

These angles were included in the calculations, but the simplification of assuming all impedances at the same angle gives close approximations and

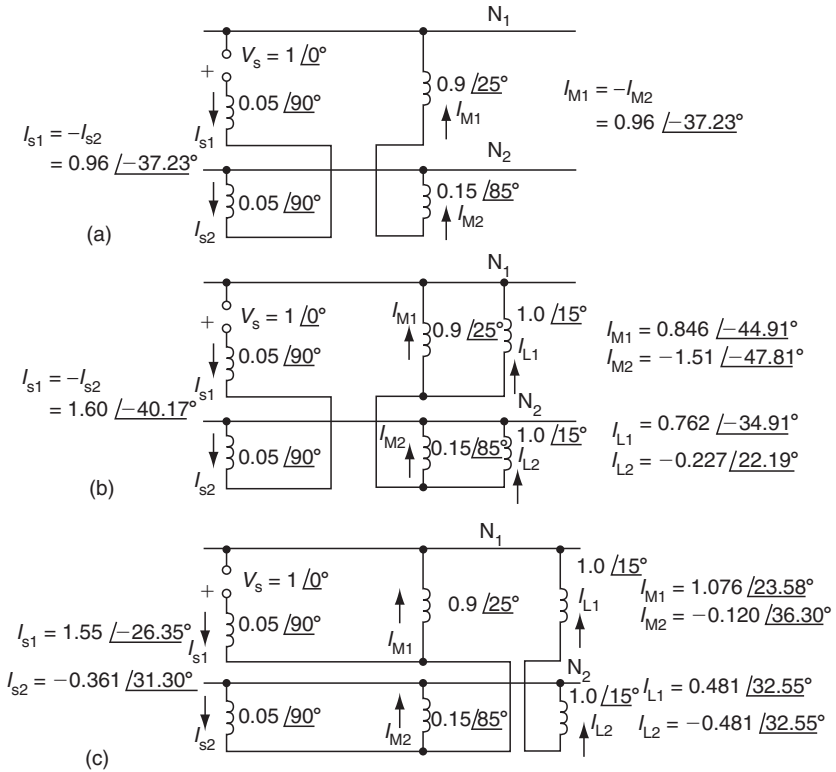

FIGURE 11.8 Positive- and negative-sequence currents for an open-phase supply to a motor with and without associated static load. Values in per unit on the motor base: (a) open-phase sequence currents with motor only; (b) open-phase sequence currents with static load on motor bus, phase open on system side of motor; (c) open-phase sequence currents with static load on the motor bus, phase open between motor and the load.

does not change the trends shown. With all values at 90° , for example, $I_{s1} = 0.87$ pu instead of the 0.96 pu in Figure 11.8a.

From these sequence currents, it is observed that on either side of the open $I_a = I_1 + (-I_2) = 0$ correctly. The sound phase currents are

$$\left. \begin{aligned} I_b &= a^2 I_1 + a I_2 = -j\sqrt{3} I_1 \\ I_c &= a I_1 + a^2 I_2 = +j\sqrt{3} I_1 \end{aligned} \right\} \text{when } I_1 = -I_2 \quad (11.16)$$

so in Figure 11.8a, I_b and I_c currents are 1.66 pu. Thus, it is seen that an open phase provides very low-phase currents relative to the normal motor-load current of about 1 pu; consequently overcurrent relays are not adequate to detect an open phase.

When static load is connected in parallel with the motor, as shown in Figure 11.7 and calculated in the examples of Figure 11.8b, the continued rotation of the motor generates a voltage on the opened phase. This continues to energize the load connected to this phase. The power is transferred across the motor air gap and reduces the motor shaft power so that pullout may occur. One example that is indicated shows that the motor would pull out at 20% of rated load, with static load three times larger than the motor load; or at 50% of rated load, with static load equal to the motor load. In addition, the low value of the motor negative-sequence impedance implies that a large portion of negative-sequence current flows in the motor to increase heating. This distribution is illustrated in Figure 11.8b. The motor negative-sequence current can be low, as shown in Figure 11.3c, only when the static load is single phased.

The fundamental for an open phase is that the positive- and negative-sequence currents are equal and opposite as long as zero sequence is not involved. This is useful to develop the unbalance currents through wye–delta transformer banks. These, as well as the calculations in Figure 11.8, are for the conditions immediately after the phase opens and before the motor slows down, stalls, or its internal impedances change, and so on.

The currents for an open phase on the primary side of a delta–wye transformer supplying a motor are shown in Figure 11.9, and in Figure 11.10 for the open phase on the secondary motor side. As developed in Chapter 3, if positive-sequence current is shifted 30° in one direction through the bank, the negative-sequence current shifts 30° in the opposite direction.

The current directions shown in the circuit diagram for these two figures are correct for the phasor diagrams. Without these specific phasor diagrams, the I_B in Figure 11.9 could be shown into the motor as indicated, but at $\sqrt{3}$ magnitude with I_C at $\sqrt{3}$ flowing to the source. This is actually the flow, and is indicated in Figure 11.9 by the phasor diagram, showing that I_B flows as indicated, but I_C is 180° from I_B , both at $\sqrt{3}$ magnitude. If I_B and I_C were shown in opposite directions in the circuit diagram, the correct phasor diagram would be to show I_B and I_C in phase. These currents can be traced through the transformer with the unbalances indicated, recalling that 1.0 pu current in the wye winding appears as 0.577 pu current in the delta winding.

Negative-sequence voltage can be used to detect unbalance in motor circuits. By fundamental definition $V_2 = -I_2 Z_2$. With reference to the example of Figure 11.8, the per-unit negative-sequence voltages on the two sides of the open phase for situations a and b would follow. For situation c, $V_{2S} = V_{2M}$ because there is no open phase between the supply and the motor.

	Case A	Case B
$V_{2S} =$	$00.96 \times 0.05 = 0.048$	$1.6 \times 0.05 = 0.08$
$V_{2M} =$	$00.96 \times 0.15 = 0.144$	$1.5 \times 0.15 = 0.227$

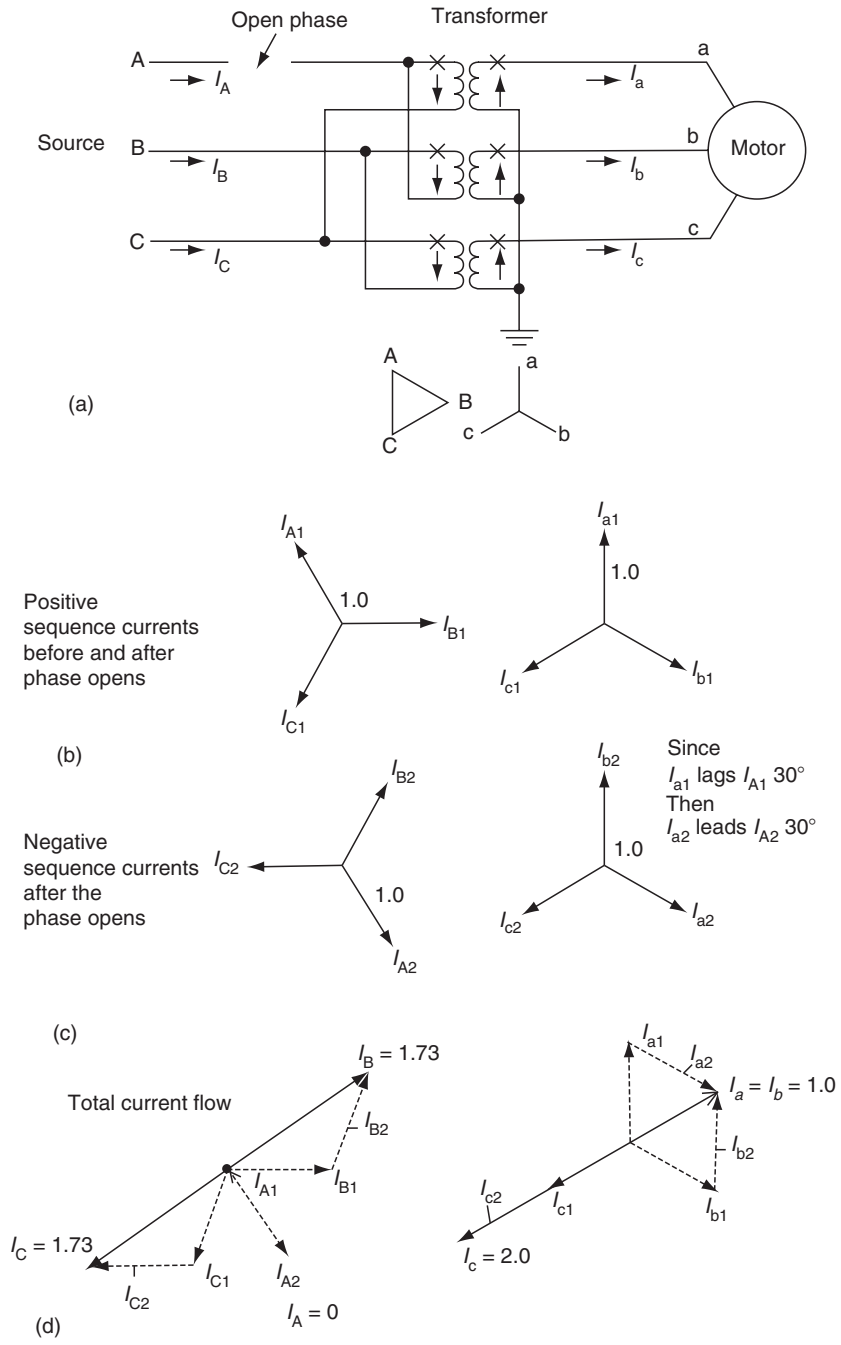

FIGURE 11.9 (a) Unbalanced current flow through a delta-wye transformer bank to a motor for phase A open on the source side. (b) Positive-sequence currents before and after phase opens. (c) Negative-sequence currents after the phase opens. (d) Total current flow.

When the open phase is downstream or between the V_2 measurement and the motor, the negative-sequence voltage relay will “see” V_{2S} , which can be quite low because of the low-impedance source. When the open phase is upstream or between the V_2 measurement and the supply, the relay will “see” V_{2M} , which is generally larger. Thus, negative-sequence voltage is most useful for upstream open phases, with phase-current comparison for the downstream ones.

11.12 UNBALANCE AND PHASE ROTATION PROTECTION

As suggested in Section 11.11, there are several handles available for unbalance detection: (1) magnitude differences between the three-phase currents, (2) the presence of negative-sequence current, and (3) the presence of negative-sequence voltage. All three are used for protection.

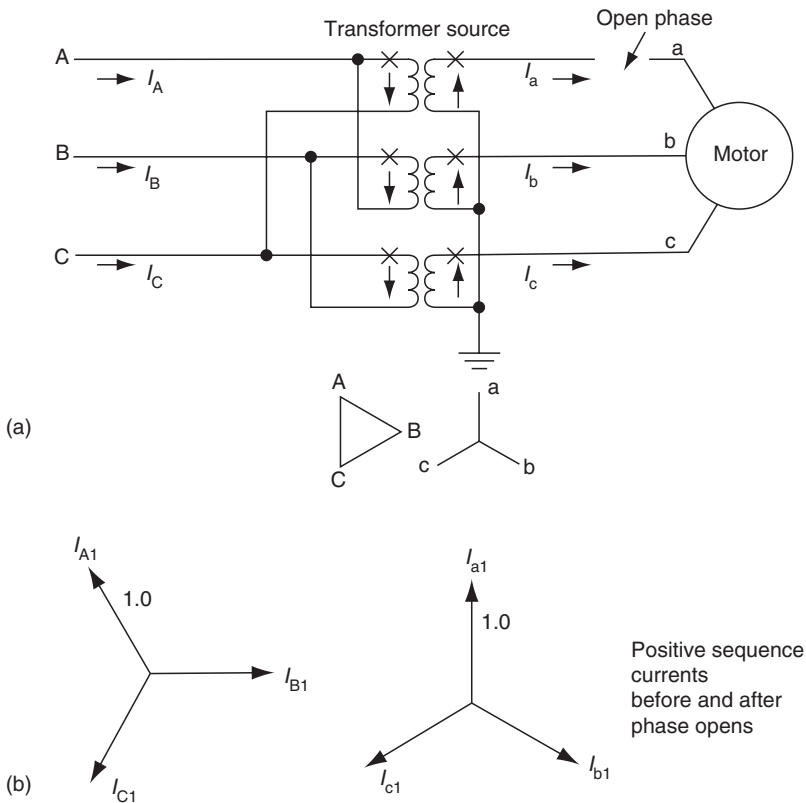

FIGURE 11.10 (a) Unbalanced current flow through a delta-wye transformer bank to a motor for phase A open on the motor or secondary side. (b) Positive-sequence currents before and after phase opens. (Continued on next page.)

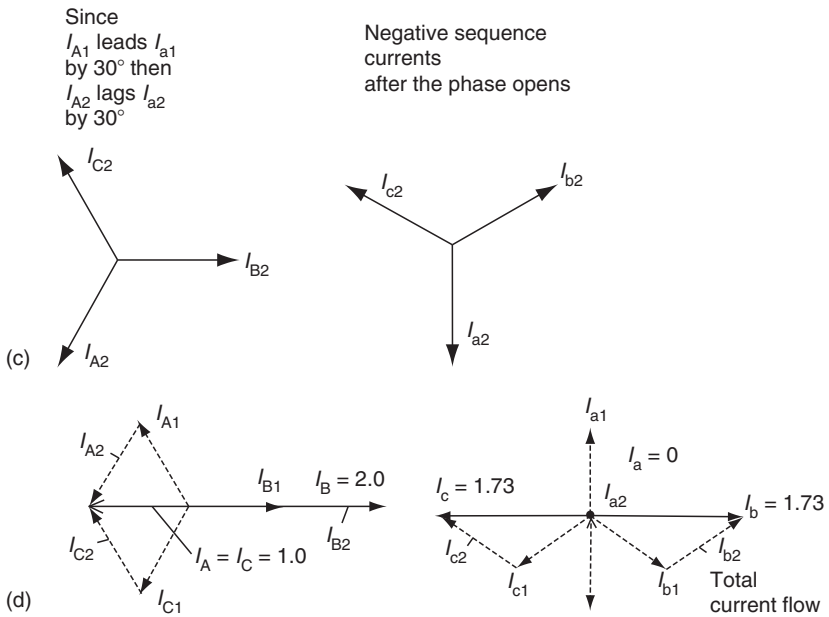

FIGURE 11.10 (continued) (c) Negative-sequence currents after phase opens. (d) Total current flow.

The current balance type (46) compares the phase current magnitudes and operates when one phase current is significantly different in magnitude from either of the other two phase currents. This is very effective protection for individual motor feeders to detect open phases or unbalances in that circuit. If other loads are supplied by the circuit to which this protection is connected, care should be taken to ensure that any open phase or unbalance would not be camouflaged by the balanced current to the sound load. One relay should be applied for each load or feeder. The typical minimum sensitivity of these relays is about 1 A in one phase with zero current in the other, or 1.5 pu in one phase and 1 pu in the other.

Another type (46) responds to the negative-sequence current, either instantaneously with a fixed time delay added, or following the $I_2^2 t = K$ characteristic, as used for generator protection. These types of relays are not widely applied for motor protection.

The negative-sequence voltage type (47) is recommended to detect phase unbalance and phase reversal in the supply or source circuits. Ideal operating sensitivities are about 0.05 pu V_2 . One such relay should be connected through VTs (either wye-wye or open-delta VTs) to each secondary supply bus. As shown in [Section 11.11](#), sufficient V_2 voltage is generally available for open phase in the source or upstream system. They should not be applied

for open-phase downstream or between the relay and motor, for as indicated, this V_2 voltage may be quite low.

When the phases are reversed, 1 pu V_1 becomes 1 pu V_2 , so the negative-sequence relay certainly responds to phase reversals. Phase-reversal relays also are available that are equivalent to a small motor. Normal phase rotation produces restraint or contact-opening torque, whereas phase reversal causes operation or contact-closing torque.

11.13 UNDERVOLTAGE PROTECTION

Low voltage on a motor results in high current and either failure to start, to reach the rated speed, or to lose speed, and perhaps pull out. Very often, protection for undervoltage is included as part of the motor starter, but an inverse time undervoltage relay (27) is recommended to trip when prolonged undervoltage exists and as backup.

11.14 BUS TRANSFER AND RECLOSING

When motors, either induction or synchronous, are reenergized before they have stopped to rotate, high transient torques can result, with possible damage or destruction. This can occur when a rapid transfer of motors is made from a bus that has lost voltage to a live auxiliary bus. Such transfers are necessary to maintain vital services to the auxiliaries supplying large generating plants or to critical industrial processes.

Another example is industrial plants supplied by a single-utility tie. Problems in the utility will require opening of the tie. Most experiences indicate that many faults in the utility are transient, resulting from lightning induction, wind, or tree contacts. As the utility is anxious to restore service promptly to its customers, the utility frequently uses high-speed reclosing (about 0.20–0.60 sec), and thus reenergizes the motors, with possible damage.

The safe limits for reconnection of motors are complex and beyond this chapter's scope. If rapid transfer is mandatory, special attention should be given to this during the design stage. Otherwise, the best policy is either to delay reclosures that reenergize induction motors, or to ensure that the motors are quickly disconnected from the system. For induction motors, reenergization should not occur until the motor voltage has dropped to 33% or less of normal.

For synchronous motors, reclosing or reenergizing must not be permitted until proper resynchronization can be effected. This means opening the motor supply promptly on the loss of supply.

An effective means to open the supply breaker under these conditions is the application of an underfrequency relay. Ideal underfrequency relay (81) setting would be 98%–97% of rated, with time to override the momentary voltage dip effects, but before reenergization can take place. If the plant has local generation, or there are other ties with generation of the supply feeder,

care should be taken to ensure that the frequency declines on loss of the utility. Generation sufficient to maintain load, particularly at light-load periods, results in negligible frequency change.

11.15 REPETITIVE STARTS AND JOGGING PROTECTION

Starting motors repetitively with insufficient time between these starting times, or operating them with extreme load variations (jogging), can result in high motor temperatures. It is possible for a high temperature to follow a short-time load peak with subsequent low current load in normal operation and not exceed the motor limits. Thermistors on smaller motors and an integrating thermal overload unit responding to total heating (see Equation 11.13) for larger motors provide a means of protection. Relays (49) operating on both overcurrent and temperature have been used. They operate with high current and high temperature. A high temperature without overload or a high overload without high temperature may not cause operation. Application of these requires careful analysis of the motor. However, the microprocessor units can monitor this effectively.

11.16 MULTIFUNCTION MICROPROCESSOR MOTOR PROTECTION UNITS

Microprocessor motor protection units combine the various protection techniques for motor protection, as covered earlier, along with control, data collection and reporting (either locally or remote), and self-diagnostic features. The basic protection is essentially the same as has been provided over many years with individual relays. Thermal protection using thermal replica or RTD-type relays has been the most imprecise part, and the microprocessor units offer significant improvement. However, it should always be remembered that although microprocessors are very accurate, thermal limits are not precise. Designers can provide safe- or dangerous-operating zones, but it is difficult to supply a single curve as per the desire and demand of engineers.

The microprocessor unit establishes electrical, thermal, and mechanical models that are derived from the input current, voltage, manufacturers' motor data, and optionally RTDs within the motor. These models are used in the microprocessor algorithms to provide protection that is modified with time.

Some of the features that are available in modern microprocessor based relays that are designed to enhance the level of protection available for motor protection include the following:

1. Multiple set points that include setting of alarms in addition to tripping functions. For example, temperature-sensing devices may be set at a value that is below the insulation class level to provide alarms when

temperatures exceed the expected full-load temperature rise levels. Trip settings can be set at a temperature corresponding to the insulation class level or above depending on the criticality of the process served.

2. Logic to prevent overheating caused by excessive starts in a given period. Settings for the number of starts and period are set based on the recommendations of the manufacturer.
3. “Smart” thermal overload protective elements that can track the real-time thermal capacity of the motor and factor in such things as the effect of motor speed on the amount of cooling provided.
4. Logic to prevent motor starting when voltage is too low to assure a successful start.
5. Wide setting ranges, programmable time–overcurrent curves, multiple setting groups, and programmable logic allow protection to be customized to fit the specific characteristics of the motor protected.
6. Better monitoring of motor performance is allowed by providing a full line of metering and oscillography capability.

11.17 SYNCHRONOUS MOTOR PROTECTION

The protection discussed in the foregoing for induction motor protection is applicable to synchronous motors, with additional protection for the field and for asynchronous operation. These motors usually include control and protection for starting, field application, and synchronizing. In addition, the following protection should be applied or considered.

As illustrated in [Figure 8.16](#), reduction or loss of excitation requires reactive power from the power system; thus, lagging current flows into the motor. For small units, a power factor relay (55) is recommended. This relay operates when current into the motor lags more than 30° . The usual maximum current sensitivity occurs when the current lags 120° , so a large current is required for typical loss of field lagging currents of $30\text{--}90^\circ$. For large synchronous motors, distance loss-of-field relays, as described for generators, are recommended (see [Section 8.11](#)). This provides improved protection for partial loss of field in addition to complete loss.

Out-of-step protection may or may not be required, depending on the system and motor. Faults in the system that momentarily reduce the motor voltage may cause the voltage angles between the system and motor to swing apart sufficiently that, on fault clearing, the motor cannot recover and so will go out of step.

If the motor is running synchronously, only DC voltage exists in the field or exciter windings. When it falls out of step from system disturbances or loss of field, ac voltage appears, which can be used to detect these conditions if the machine has brushes. With modern brushless exciters, the power factor relay (55) will provide both pullout and loss-of-field protection.

11.18 SUMMARY: TYPICAL PROTECTION FOR MOTORS

Typical protection recommended and commonly applied for the protection of motors is summarized in [Figure 11.11](#). The application of the various relays is covered in the foregoing. These are general recommendations, recognizing that any specific application may be used more or less depending on local circumstances, economics, and individual preferences.

11.19 PRACTICAL CONSIDERATIONS OF MOTOR PROTECTION

A general problem that has existed over the years with regard to motor protection is the lack of availability of complete data on the system driven by a motor to the protection engineer. Electrical engineers responsible for specifying and setting motor protection frequently do not communicate with the mechanical engineers who are familiar with the nature of the loads that are driven. As a result, motor protection is often applied on the basis of best estimates, standards, and on motor name-plate data. If the motor trips during starting conditions, the setting is increased in small steps until nuisance trips subside. This practice may be satisfactory for small, general-purpose applications in which investment is small and the process is not critical. However, for larger or more critical applications, the protection engineer should make every effort to understand the details of the loading conditions that are connected to the motor as well as the operating characteristics of the motor, so that the related protection can be properly specified and set to minimize the potential for damage to the motor or shutdown of the process that it serves. Oscillography capability provided by many modern microprocessor relays provides an effective tool for obtaining pertinent data during the process of placing a facility in service and while functioning during normal in-service conditions.

BIBLIOGRAPHY

- ANSI/IEEE Standard C37.96, Guide for AC Motor Protection, IEEE Service Center.
- Brighton, R.J. Jr. and Ranade, P.N., Why overload relays do not always protect motors, *IEEE Trans. Ind. Appl.*, IA 18, November–December 1982, pp. 691–697.
- Dunki-Jacobs, J.R. and Ker, R.H., A quantitative analysis of grouped single-phased induction motors, *IEEE Trans. Ind. Appl.*, IA 17, March–April 1981, pp. 125–132.
- Gill, J.D., Transfer of motor loads between out-of-phase sources, *IEEE Trans. Ind. Appl.*, IA 15, July–August 1979, pp. 376–381; discussion in IA 16, January–February 1980, pp. 161–162.
- Lazar, I., Protective relaying for motors, *Power Eng.*, 82, No. 9, 1978, pp. 66–69.
- Linders, J.R., Effects of power supply variations on AC motor characteristics, *IEEE Trans. Ind. Appl.*, IA 8, July–August 1972, pp. 383–400.

- Regotti, A.A. and Russell, J.D. Jr., Thermal limit curves for large squirrel cage induction motors, IEEE Joint Power Generation Conference, September 1976.
- Shulman, J.M., Elmore, W.A., and Bailey, K.D., Motor starting protection by impedance sensing, *IEEE Trans. Power Syst.*, PS 97, 1978, pp. 1689–1695.
- Woll, R.E., Effect of unbalanced voltage on the operation of polyphase induction motors, *IEEE Trans. Ind. Appl.*, January–February 1975, pp. 38–42.

12 Line Protection

12.1 CLASSIFICATIONS OF LINES AND FEEDERS

Lines provide the links—the connections—between the various parts of the power system and the associated equipment. Power generated at low voltages is stepped up to higher voltages for transmission to various stations, where it is stepped down for distribution to industrial, commercial, and residential users.

Most power systems have two to many voltage levels. Over the 10 year history of ac systems, the actual three-phase voltages used have varied considerably, with no international standards. In the United States, the IEEE Standards Board adopted a set of standards in 1975 proposed by the Industrial Applications Society. These are summarized in [Table 12.1](#). The class designations are not completely or uniformly agreed on between the IEEE Power Engineering Society and the Industrial Application Society, both involved in power systems. Within the power utility area, there has been, and continues to be, a general understanding of voltage classes as follows:

Industrial distribution—34.5 kV and lower

Subtransmission—34.5–138 kV

Transmission—115 kV and higher

with the last class generally divided into:

High voltage (HV)—115–230 kV

Extrahigh voltage (EHV)—345–765 kV

Ultrahigh voltage (UHV)—1000 kV and higher

As indicated, these are not well defined, so the range can vary somewhat in any specific power system. With time, more conformity with the standards will take place, but there exist many different and nonstandard voltages that were adopted many years ago and will not be changed for a long time. Some of these, but not all, are indicated in the table as optional or existing.

The voltage values indicated represent the nominal and typical rms system voltages (line-to-line unless so indicated) commonly designated in technical information and communication. As power flows through a system, the actual

TABLE 12.1
Standards Proposed by the Industrial Applications Society

		Nominal rms Line-to-Line ^c System Voltage				
IAS ^a	PES ^b	Three-Wire Systems		Four-Wire Systems		Maximum Voltage
		Preferred	Optional or Existing	Preferred	Optional or Existing	
Low (LV)	No voltage class stated (ANSI C84.1)			208Y/120		220Y/127
			240V	240/120 Tap		245/127
Medium (MV)		480V	600V	480Y/277		508Y/293,635
			2,400V			2,540
		4,160V		41,660Y/2,400		4,400Y/2,540
			4,800V			5,080
			6,900V			7,260
						8,320Y/4,800
				12,000Y/6,930	12,700Y/7,330	
				12,470Y/7,200	13,200Y/7,620	
				13,200Y/7,620	13,970Y/8,070	
		13,800V			13,800Y/7,970	14,520Y/8,380
					20,780Y/12,000	22,000Y/12,700

				22,860Y/13,200	24,200Y/13,970
			23,000V		24,340
				24,940Y/14,400	26,400Y/15,240
			34,500V	34,500Y/19,920	36,510Y/21,080
High (HV)	Higher voltage (ANSI C84.1)		46 kV		48.3 kV
		69 kV			72.5 kV
		115 kV			121 kV
		138 kV			145 kV
			161 kV		169 kV
		230 kV			242 kV
Extra-high (EHV)	ANSI C92.2	345 kV			362 kV
		500 kV			550 kV
		765 kV			800 kV
Ultra-high (UHV)		1,100 kV			1,200 kV

^aIAS: IEEE Industrial Applications Society. Their voltage class designations adapted by IEEE Standard Board (LB 100A).

^bPES: IEEE Power Engineering Society. Standard references indicated in the table.

^cThe second voltage for the three-phase four-wire systems is line to neutral or a voltage tap, as indicated.

Source: *IEEE Standard Dictionary*. With permission.

voltage varies from point to point from the generators to the ultimate terminals from the drops, transformer ratios, taps, regulators, capacitor banks, and so on; hence, arbitrary, nominal, or typical values are selected as indicated.

The terminals of the lines and feeders and the location of equipment such as transformers, generators, and circuit breakers, are known as stations, plants, and substations. The specific designation is neither well defined nor standardized. A generating station or plant is obvious. A substation is smaller and less important than a station. In one system relative to another, a station in one might be designated on a substation in the other, and vice versa. So common designations are generating stations, switching stations, power stations, substations, distributions stations, and so on.

Many lines are two terminal, but there are a number of multiterminal lines with three or more terminals. These may interconnect stations, or substations, but frequently, are taps to supply loads. Thus, lines of all voltage levels can become distribution circuits. When an industrial or commercial complex with a large load requirement is located near a transmission line, it often becomes economical to tap the line. Distribution lines usually have many taps, either three phase or single phase, as they supply loads along their routes.

Three-phase line impedance angles vary with the type, size of the conductors, and spacings. Typical ranges for different voltages are as follows:

kV	Angles
7.2–23	25°–45°
23–69	45°
69–230	60°–80°
230 and above	75°–85°

12.2 LINE CLASSIFICATIONS FOR PROTECTION

For protection purposes, lines in this book, are classified as

1. *Radial or feeders*: These have a positive-sequence source at only one terminal. Typically, they are distribution lines supplying power to nonsynchronous loads. As indicated in [Section 4.8](#), induction motors are usually not considered as sources. For faults on the line, current to the fault is only from this source end. With both ends grounded and a ground fault on the line, current can flow from both ends, but tripping the positive-sequence source deenergizes the fault. However, zero-sequence mutual coupling from adjacent line(s) can continue the ground fault; therefore, the ground sources must be tripped. With the

increased frequency of installations of distributed generation, as discussed in [Chapter 8](#), radial lines can be converted to a network line on short notice.

2. *Loop or network*: Loop lines are those with positive-sequence sources at two or more ends. In general, these are all types of transmission lines and can include distribution circuits. Fault current to the line faults is supplied from these source terminals, and all source terminals must be tripped for both phase and ground faults. Power systems in the United States are generally multi-grounded; thus, positive-, negative-, and zero-sequence currents can flow to the line faults. If one end of the two-terminal line is grounded, then the line is a loop for phase faults, but a radial for ground faults. Again mutual induction from parallel lines can induce significant zero sequence into the line. The effect is covered later in this chapter.

Line length is another means by which lines are classified. Such classification is most significant with regard to higher-voltage lines that operate in the network. Line length has an impact on issues relating to the application of effective protective systems. Lines are typically classified as short, medium, or long. A measure of line length that is significant with regard to protection is the ratio of source impedance to line impedance (SIR). Higher SIRs imply shorter lines. Lines with SIRs above 4 are generally classified as short, and lines with SIRs below 0.5 are generally classified as long. Lines with SIRs between 0.5 and 4 are classified as medium.

12.2.1 DISTRIBUTION LINES

The design of distribution systems varies, depending on the nature and the density of the load served. Load within business districts of larger cities and large industrial complexes tends to be highly concentrated and, by its nature, requires a high level of reliability. Distribution circuits to supply such load are often made up of underground cable. Low-tension networks (LTNs) are often used to supply business districts within larger cities. The majority of distribution circuits that are in service, however, supply load that is made up of a mixture of rural load and supply to smaller cities, towns, and villages. Distribution lines that supply this type of load are typically overhead and usually operate at voltages between 4 and 34 kV. For distribution circuits, 13.2 kV is the common voltage utilized, and 23 and 34.5 kV are becoming more popular in areas that have a higher load density.

A typical overhead line is about 10–20 miles in length, with the main portion of the line constructed for three-phase operation. Customers who require three-phase service are supplied from the main line or from three-phase taps off the main line. Customers requiring single-phase service are supplied from the main line or from single-phase taps off the main line.

A sound protection philosophy for distribution circuits should include the following:

1. Permanent faults should outage as few customers as practical. The main line should not be permanently outaged for faults on taps.
2. Sensitivity requirements need to be established for settings or operating ratings of distribution protective devices to promote safety of the personnel, the public, and of system facilities. These requirements should assure with high probability that all faults on distribution circuits will be detected and promptly cleared.
3. Automatic restoration of a circuit following a trip due to a fault should occur to the maximum extent possible. This practice acts to facilitate prompt restoration of service following a temporary fault. Experience has shown that up to 80%–90% of faults on overhead distribution lines are temporary in nature.

To meet the above criteria, typical overhead distribution circuits are sectionalized with numerous fault interrupting devices. Distribution transformers that tap the lines to provide service to customers are usually protected with fuses. Taps off the main line are protected with fuses, automatic reclosers, and sectionalizers. Automatic reclosers and sectionalizers are also often installed in the main line. A relayed circuit breaker is typically installed at the line terminal at the substation, although automatic reclosers are also sometimes applied at the terminal location. In recent years, techniques to apply new technologies for obtaining a greater level of automation on distribution circuits have been developed and applied in order to improve service reliability.

12.2.2 TRANSMISSION AND SUBTRANSMISSION LINES

Transmission lines are used to transmit power from generation sources to regional load areas or adjacent power systems. Such lines are operated in network in order to provide the required reliability. Transmission lines do not normally serve load directly to customers except in some cases, when economically justified, to serve customers who utilize very large amounts of power. Transmission line terminals are equipped with relayed circuit breakers. These breakers may use oil, gas, or vacuum as the interrupting and insulating medium.

Protection objectives for transmission lines should include the following:

1. Faults should be cleared as fast as possible in order to enhance the transient stability of the power system, minimize voltage disturbance, and damage to equipment.
2. During a system fault condition, only those breakers required to isolate the fault should trip, in order to minimize the scope of the resultant outage.

3. Overhead transmission lines should be reenergized automatically, following the clearing of a fault in order to restore the line to service, if the fault is temporary in nature.
4. Protection should not restrict the line from being loaded to its maximum short-term emergency load rating, to which it is operated.

It is desirable for all transmission line faults to be detected by instantaneous relays in order to meet the objectives already mentioned. It is acceptable, however, for highly restricted faults to be detected and cleared by action of time delay relays.

Subtransmission lines transport power to local load areas or directly to larger customers. Protection for subtransmission lines will generally be a blend between that described for transmission and that for distribution lines. Specific protection applications will depend on the nature of the associated system and the importance of the subtransmission line being protected.

12.3 TECHNIQUES AND EQUIPMENT FOR LINE PROTECTION

The relay protection techniques available for all line protection includes the following:

1. Nondirectional instantaneous overcurrent
2. Nondirectional inverse-time overcurrent
3. Nondirectional definite-time overcurrent
4. Directional instantaneous overcurrent
5. Directional inverse-time overcurrent
6. Directional definite-time overcurrent
7. Current balance
8. Directional distance—instantaneous or step or inverse-time
9. Pilot with a communication channel between terminals (see [Chapter 13](#))

All of these are employed individually or in various combinations for both phase and ground protection of lines. These relay types are discussed in [Chapter 6](#) and their applications are covered in this chapter. The current-balance type compares the currents in parallel lines to detect an unbalance resulting from a fault in one line. It is not in general use in the United States. This is because it is not applicable to single lines; it must be disabled for single-line operation; it requires interconnections between the controls for the two lines, which is not desirable for operation and testing; and it can experience difficulties for a fault involving both paralleled lines.

Circuit breakers are ubiquitous in power systems, but in the distribution areas, fuses, reclosers, and sectionalizers are in common use. A brief review of these follows.

12.3.1 FUSES

The continuous, rated current of the fuse must be equal to or greater than the maximum short-time load that will pass through it. In addition, the symmetrical-interrupting rating of the fuse should be equal to or greater than the maximum fault current. Attention must be given to system voltage and insulation level and the system X/R ratio. Fuses operate in a time–current band between maximum clearing times and minimum-melt (or damage) times. The difference is the arcing time within the fuse.

The minimum-melt time is important when the fuse backs up or over-reaches other devices. The latter devices must clear the fault before thermal damage can occur to the fuse, as indicated by the minimum-melt time.

Types of fuses utilized include expulsion, nonexpulsion, and current-limiting. Expulsion type fuses are the most common type of fuse used for pole-mounted outdoor applications. Standards have been developed in the early 1950s that classify fuses based on the slope of their operating characteristics. Fuses are classified as “K” (fast), “T” (slow), or “N”. A benefit of such standards is that it allows utilities to purchase and stock fuses from different manufacturers and be assured that their operating characteristics will fall within defined limits.

12.3.2 AUTOMATIC CIRCUIT RECLOSERS

Commonly known as reclosers, these are a type of circuit interrupters with self-contained controls to sense overcurrent and open on faults, either instantaneously or with the time delay. They can be programmed to initiate automatic reenergization of the circuit (reclosing) at variable intervals if the fault persists, and eventually to lock out.

Three-phase reclosers may have both phase and ground units. Single-phase reclosers cannot have ground sensors, but rather, they rely on the phase unit for line-to-neutral or line-to-ground faults involving the phase to which they are connected.

Single-phase reclosers for single-phase taps can be used on three-phase feeders. The advantage is that service can be maintained on the unfaulted phases. However, three-phase reclosers are generally recommended to avoid single-phasing three-phase motors and potential ferroresonance, as discussed in [Section 7.9](#).

Reclosers are designed with both hydraulic and electronic controls. Hydraulically controlled reclosers sense overcurrents by means of a series trip coil, connected in series with the line. When current exceeds the trip rating of the coil, a plunger is drawn into the coil, which causes the recloser contacts to open.

Electronically controlled reclosers are more flexible and accurate than hydraulically controlled reclosers, but are also more expensive. The electronic control can be easily adjusted to change the time–current tripping characteristic,

minimum trip setting, and the closing sequence of the recloser. The electronic control also provides a wide range of accessory enhancements to meet the specific needs of the user.

Reclosers are designed to use either oil or vacuum as the interrupting medium. In oil reclosers, the same oil is used for both arc interruption and basic insulation. Vacuum reclosers use either oil or air as the basic insulation medium.

Reclosers are used because their cost is generally less than conventional breakers and separate relays.

12.3.3 SECTIONALIZERS

A circuit-isolating mechanism that is not rated to interrupt fault current is a sectionalizer. It opens when it is deenergized after sensing a preset number of downstream faults. It is manually reset.

Sectionalizers are applied in conjunction with backup reclosers or breakers, and count the operations of the backup device during fault conditions. Counts are registered by the sectionalizer only when fault current flow through the sectionalizer had been detected prior to the operation of the backup device. After a given number of counts, as selected as a part of the sectionalizer setting, the sectionalizer opens to isolate the faulted section of the line when the backup device is in the open position, and the section of line where the sectionalizer is located is in a deenergized state. The object is for the sectionalizer to remain closed on temporary faults—the backup device will trip and reclose to restore the line to service for such faults prior to the sectionalizer opening. For permanent faults, the sectionalizer recognizes that one or more trips have occurred after the backup device reclosed, and it subsequently opens to isolate the faulted portion of the line. After the sectionalizer opens, the backup device automatically recloses to restore to service that portion of the line up to the sectionalizer location. Application of sectionalizers requires that the backup interrupting device be capable of detecting faults in the sectionalizer zone of protection.

12.3.4 COORDINATING TIME INTERVAL

The coordinating time interval (CTI) is the time interval between the operation of protection devices at a near station and the protection devices at a remote station for remote faults that the near-station devices overreach. Thus, for these remote faults, the near-station devices' operating times must not be less than the sum of the remote devices' operating time and the CTI. Faults on the remote line should be cleared by the remote protection device and backed up by the near-station devices. This is illustrated in [Figure 12.1](#).

The CTI consists of

1. Breaker fault-interruption or fault-clearing time, typically 2–8 cycles (0.033–0.133 sec).

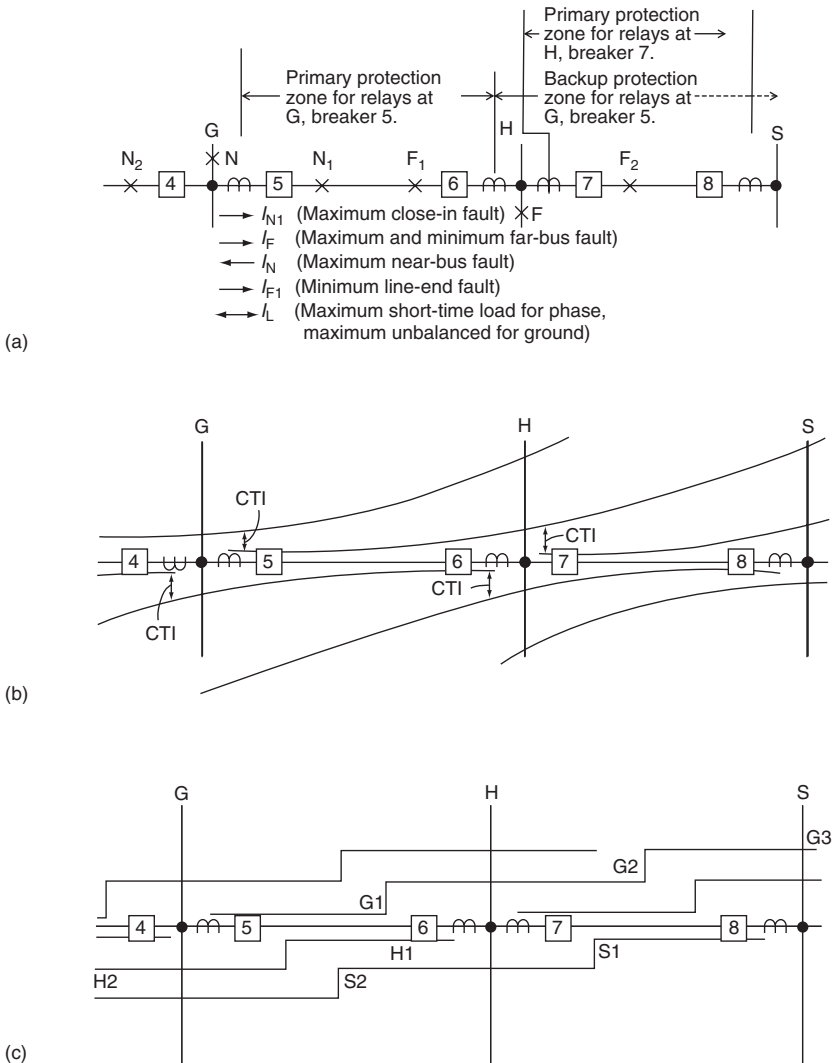

FIGURE 12.1 Protection zones, fault data requirements, and time coordination curves for typical loop-type lines. For distribution, radial lines, current flows only in one direction; hence, protection zones, fault data, and time coordination curves are required for only one direction: (a) important comments for setting relay at G for breaker 5 to protect time GH; (b) coordination with directional inverse-time-overcurrent relays; (c) coordination with directional distance units.

2. Relay overtravel (impulse) time: The energy stored in the electro-mechanical induction disk or solid-state circuitry will continue operation after the initiating energy is removed. Typically, this is not more

than 0.03–0.06 sec for electromechanical units; less, but not zero, for solid-state units.

3. Safety margin for errors or differences in equipment-operating time, fault current magnitudes, CT ratios, and so on.

The CTI values frequently used in relay coordination range between 0.2 and 0.5 sec, depending on the degree of confidence or the conservatism of the protection engineer—0.3 sec, is the frequently used CTI value.

12.4 COORDINATION FUNDAMENTALS AND GENERAL SETTING CRITERIA

The “protection problem” was outlined in [Section 6.3](#) (see [Figure 6.5](#)). The ‘time solution’ applies to lines, since line protection can extend into adjacent lines, buses, transformers, motors, and so on. The settings must ensure that the phase and ground protections do not operate in these overlapping (backup) areas, until the primary phase and ground protections assigned to that area have the opportunity to clear the fault. Setting of the protection equipment to ensure this is selective setting or coordination. A backup device that should not trip “selects” with the downstream device that is closer to the fault. The downstream device that is closer to the fault and should trip, “coordinates” with the backup device that should not trip. [Figure 12.1](#) illustrates coordination on loop-type lines. Coordination on feeders or radial lines is the same, except that it moves only in one direction: from the power source to the loads.

The objective is to set the protection to operate as fast as possible for faults in the primary zone, yet delay sufficiently for faults in the backup zones. As in [Figure 6.4](#), the settings must be below the minimum fault current for which they should operate, but not operate on all normal and tolerable conditions. Occasionally, these requirements provide very narrow margins or no margins. This is especially true in loop-type lines, for which there can be a large variation in fault magnitudes with system operation. Fault currents can be high at peak-load periods with all the generation and lines in service, but quite low when equipment is removed during light-load periods. The fault study should document these extremes. When coordination is not possible, either a compromise must be made or pilot protection (see [Chapter 13](#)) applied. Thus, coordination is a “cut-and-try” process.

Although today many computer programs exist for coordination analysis, it is still important that engineers understand this process.

12.4.1 PHASE TIME—OVERCURRENT RELAY SETTING

For lines, there is rarely a thermal limit as there was for transformers. The minimum-operating current (relay pickup) must be set so that operation will not occur on the largest transient or short-time current that can be tolerated by the system. The key factors to be considered are:

1. Short-time maximum load (I_{STM}): This is the current that the circuit may be required to carry during emergencies or unusual operating conditions for intervals that can be from about 1 h or more. Practically, it is often the maximum capability of the transformer or maximum limit of the load.
2. Transient currents caused by switching operations on the power system. This includes currents that are expected during cold-load pickup conditions, recoverable power swings, transformer energization, and motor starting.

Cold load is a short-time increase in load current that occurs when a distribution feeder is reenergized after an outage. Normal feeder load is based on diversity, because not all customers require maximum load at the same time. After an outage, this diversity is lost momentarily, because all of the load is energized at the same time. The amount and duration is quite variable, depending on the circuit and the length of the outage; so experience history is usually necessary to document this.

A phase-overcurrent relay pickup of 1.25–1.5 times the maximum short-time load or greater will be required to avoid operation on short-time transients with inverse relay characteristics. The lower multiples can be used with the extremely or very inverse types, as the operating times are very long, just above pickup. The transient overcurrents may energize the relays, but subside below relay pickup before the operating time is reached. Generally, the extremely inverse characteristics match the fuse characteristics and motor-starting curves better, and therefore, are preferable for protection in the load areas. Moving back toward the source, the less inverse types are applicable.

12.4.2 GROUND TIME-OVERCURRENT RELAY SETTING

The minimum-operating current (pickup) must be set above the maximum zero-sequence current unbalance that may exist and that can be tolerated by the system. This unbalance is usually the result of unequal loading of single-phase taps among the three phases. Monitoring the unbalance and changing taps are used to keep the unbalance minimum. With this, and except for problems in coordinating with fuses, ground relays can be set lower than the phase relays for increased fault sensitivity.

Typically, 0.5 and 1.0 A taps are used where the unbalance is low, especially at the higher-voltage levels.

12.4.3 PHASE AND GROUND INSTANTANEOUS OVERCURRENT RELAY SETTING

Instantaneous overcurrent (IT) units operate with no intentional time delay, and generally in the order of 0.015–0.05 sec. This requires that they be set not to overreach any other protective device. An exception is for “fuse-saving,” discussed later.

The fundamental principles for setting the instantaneous units with reference to [Figure 12.1](#), breaker 5 at bus G, are:

1. Set at $kI_{\text{far bus max}}$ (I_{Fmax} in the figure). If there is a tap or a recloser before the far bus, use the maximum current at that device or point. k is typically 1.1–1.3. The value depends on the responses of the IT unit to a possible fully offset current and the degree of conservatism of the protection engineer.
2. If this setting value current is greater than the maximum near-bus fault (see I_{N} in [Figure 12.1](#)), a nondirectional instantaneous unit can be used.
3. If this setting value current is less than the maximum near-bus fault (see I_{N} in [Figure 12.1](#)), a directional instantaneous overcurrent unit is required, or the IT setting must be increased to avoid operation with a nondirectional type.

On feeders or radial lines, only criterion 1 is applicable. Criteria 2 and 3 are not applicable, because there is no current for faults at the back of the protection device.

The maximum current that must be considered in criterion 1 may be something other than the maximum current flow for a fault at the remote bus. For example, on lines that have considerable mutual coupling (double circuit lines), maximum current flow for setting ground instantaneous overcurrent relays may occur for a line-end fault on the adjacent line. Mutual coupling is discussed in greater detail later in this chapter. The critical current for setting instantaneous overcurrent relays may also be a low side fault on transformers tapped on the line or transient current that can exist during recoverable power swings, cold-load pickup, transformer energization, or motor starting. The basic criteria are that instantaneous overcurrent relays should be set as sensitive as possible, with the constraint that it must not operate on nonfault conditions or for any fault outside of its zone of protection. Protection engineers should recognize that instantaneous relays are a very simple and highly valuable protective function, and every effort should be taken to take advantage of its benefits.

12.5 DISTRIBUTION FEEDER, RADIAL LINE PROTECTION, AND COORDINATION

A distribution station or substation is supplied by the utility, generally through one or two transmission or subtransmission lines, depending on the size and the importance. Two supplies with two step-down transformers are shown in [Figure 12.2](#). This arrangement provides higher service continuity possibilities. The secondaries feed independent buses to which are connected various radial feeders, with only one bus indicated in the figure.

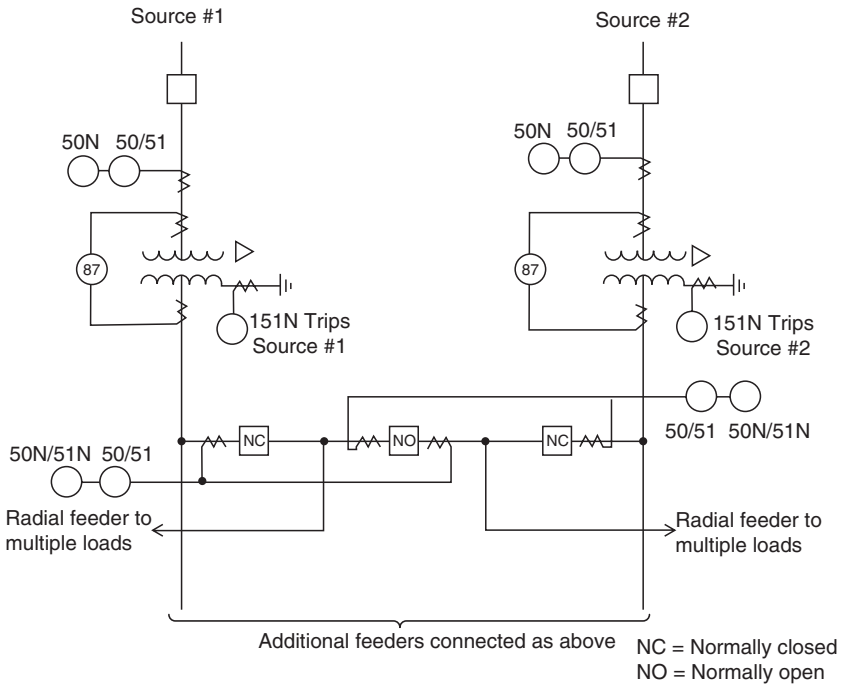

FIGURE 12.2 A multiple source distribution station.

A single, widely used supply distribution station is shown in [Figure 12.3](#), with several feeders from a single bus. For either arrangement, one typical feeder, of the many connected, is shown in [Figure 12.3](#).

With the double supply of [Figure 12.2](#), the normal breaker positions are as shown. The left feeders are fed by source 1, and the right feeders by source 2, with the NO breaker between them. With one source or one transformer out of service, for example, source 2, the right station load can be carried by source 1 by opening all the right NC breakers and closing all the NO breakers. This is an added load on the source 1 transformer; therefore, the rating can be increased by forced air and oil combinations as required.

The CTs are interconnected, as shown, to provide fault current in only the faulted feeder and zero in the unfaulted feeder for either two- or one-source operation.

The differential is shown around the transformers, but this could be extended to the high-side breaker if located at the transformer. The 87, high-side 50/51, 51N, and the neutral 151N relays, all trip the high side either directly or by transfer trip, depending on the high-side disconnection means available.

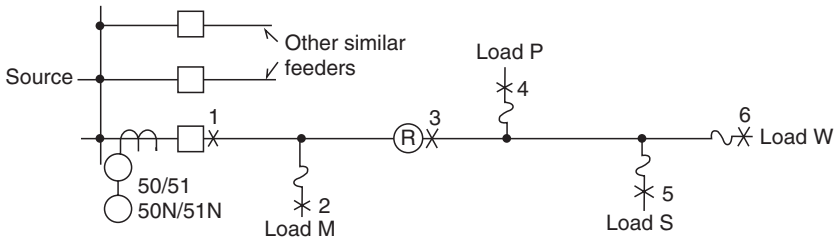

Relays at the source station:

Primary protection zones;

Between the breaker, the fuse to load M and to the recloser R.

Backup zone;

Between load M fuse and load M bus (not shown)

Between recloser R to the fuses P, S and W

Recloser R:

Primary zone;

Between recloser and the fuses at loads P, S, and W

Backup zone;

Between the fuses at P, S, W, and their respective load buses (not shown)

Fuses at the various loads:

Primary protection zones;

Between the load fuses and the respective load buses (not shown)

Backup zones;

Between the respective load buses and the loads (not shown)

FIGURE 12.3 Protection zones for a typical distribution feeder.

Additional service continuity may be obtained by interconnecting a feeder off one bus to a feeder off the other through a normally open recloser, somewhere out on the lines. With a loss of supply to one of the feeders, this NO recloser will close in an attempt to pick up the load. Should there still be a fault on this feeder, the recloser will trip and lock out. This tie recloser is not shown in the figures.

Many times, fault currents at the distribution secondary levels are determined essentially by the substation transformer and feeder impedances, the source impedances of the large power system often being very small and practically negligible. Thus, fault levels are relatively constant with system changes, except for fault resistance. This latter situation is quite variable and can be very high to “infinite,” especially for downed conductors that do not make a contact or that have only a high-resistance contact to the ground.

Fuses are widely used for phase and ground protection. However, they receive only phase or line current, whereas ground relays operate on $3I_0$ neutral current. Fortunately, fuses are applied to radial or feeder circuits where the line current equals $3I_0$ (for a phase-a-to-ground fault, $I_a = 3I_0$). Note, this is not true for loop lines. Thus, coordination of ground relays with

fuses can require ground relay settings essentially equivalent to the phase relays. High-ground relay settings can also result from high zero-sequence load unbalance by unequal phase-to-neutral or phase-to-ground loading.

Many distribution systems are four-wire multigrounded. Consequently, a neutral (fourth wire in three-phase distribution) is tied to the substation transformer ground(s) and carried along with the feeder phase(s). This is tied to ground at each pole. Faults at the pole are generally phase-to-neutral, whereas faults out on the line are probably phase-to-ground. In either situation, most of the return current will flow in the neutral wire because it is nearer the phases; hence, a lower inductance. Therefore, at the grounded station transformer-neutral, most of the return is by the neutral, rather than through the ground. Connecting the neutral ground relay between the ground and the neutral-wire connections will essentially provide $3I_0$ fault current, but this can be very small, especially for remote feeder faults. Connection of the ground relay between the transformer-neutral and the neutral (fourth)-wire connection measures the total load unbalance and fault current. This can require a high-ground relay setting, unless the loading is carefully monitored.

Because the required ground relay setting may be essentially the same as the phase relays, the tendency is to omit the ground relays. This may not be desirable in liability cases for which the absence of ground relay may suggest inadequate protection.

The protection zones for a typical distribution feeder are outlined in [Figure 12.3](#). The coordination of the various devices, where the fault current is the same or related to the transformer connections, is done conveniently by overlaying time–current characteristics available or transparent log–log paper. These can be shifted until proper coordination between the various devices is obtained. This method was used for transformer overload protection examples in [Chapter 9](#) and in [Figure 12.5](#) in the following example.

12.6 EXAMPLE: COORDINATION FOR A TYPICAL DISTRIBUTION FEEDER

A typical 13 kV feeder of several lines at a distribution substation is shown in [Figure 12.4](#). This is supplied from a 115 kV line through a 15/20/25 MVA transformer protected by a high-side fuse. Only one of the four feeders is illustrated and is typical, with the loading and protection of the other feeders similar, but different. The fault values are in amperes at 13.09 kV for solid faults at the locations shown.

If we begin at the high-side fuse, the setting and coordination of the protection is as follows. The maximum load for the 25 MVA tap is

$$25,000\sqrt{3} \times 115 = 125.5 \text{ A at 115 kV.}$$

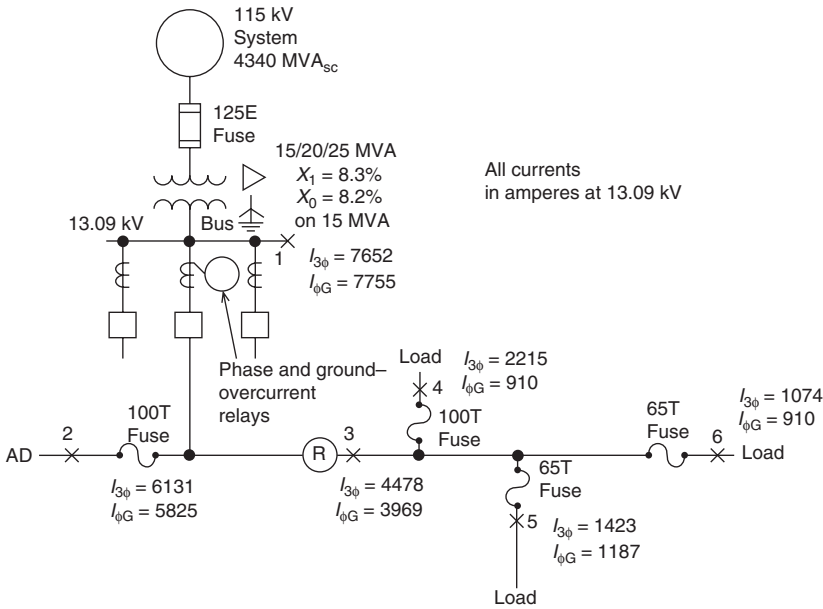

FIGURE 12.4 Typical distribution feeder serving multiple load centers.

The 125E fuse was selected for the transformer bank primary. Its operating time close to 250 A is 600 sec, which should override cold-load and magnetizing inrush transients.

The characteristics are plotted on log–log fuse coordinate paper (Figure 12.5). The abscissa is amperes at 13 kV, so the 125E fuse in the 115 kV circuit is plotted at $115/13.09 = 8.79$ times the manufacturer’s curves. Thus, the 600 sec minimum-melt current of 250 A becomes $250 \times 8.79 = 2196$ A for balanced currents. The dashed-line minimum-melt curve, shown to the left, reflects the effect of load current preheating the fuse.

Whereas phase-to-phase faults on the 13 kV side are 0.866 of the three-phase fault value (see Figure 9.20), the current in one phase on the primary is the same as the three-phase fault value. However, the primary fuse sees only 0.577 of the secondary one-per-unit current for 13 kV phase-to-ground faults (see Figure 9.20). The dashed-line curve to the right is the primary-fuse minimum-melt characteristic for secondary ground faults. For the 600 sec operating time, $2196 \times \sqrt{3} = 3804$ A is equivalent to 2196 A for a phase-to-ground fault.

The transformer through-fault overcurrent limit curve is plotted as shown. This area is discussed in Chapter 9. As shown, the transformer is protected satisfactorily against thermal damage.

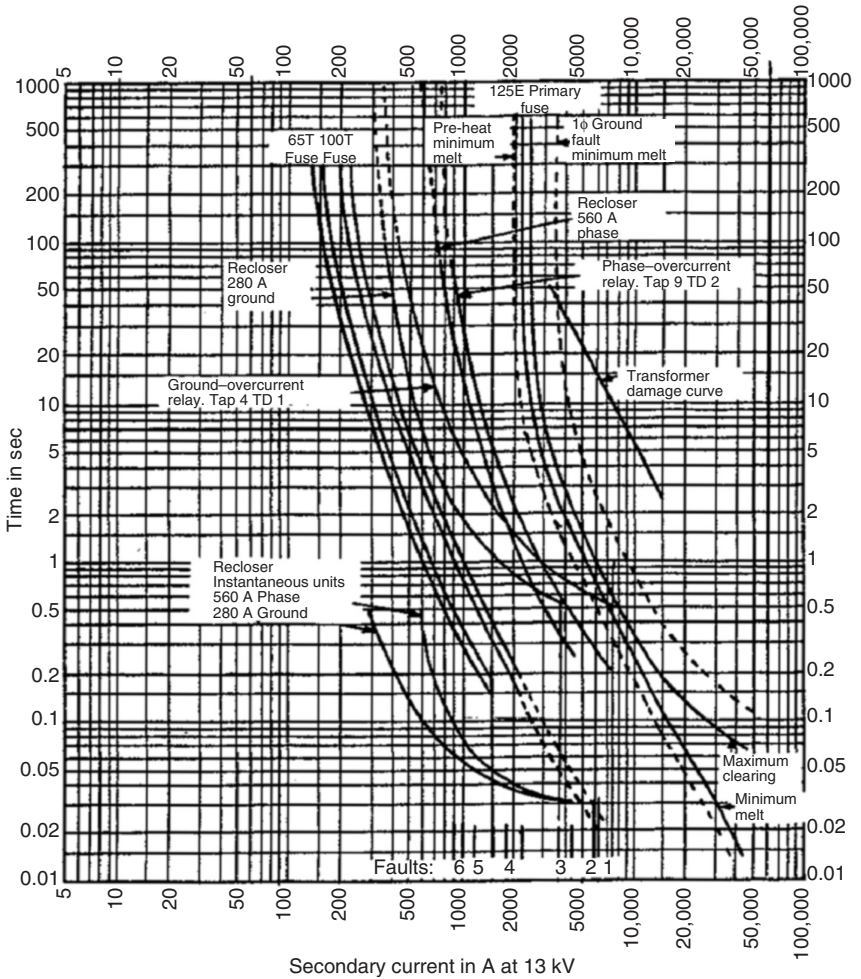

FIGURE 12.5 Typical time coordination curves for the distribution system feeder of Figure 12.4.

The 65T and 100T fuses selected on the basis of the loads served from the taps are shown plotted in Figure 12.5 from the manufacturer's curves. The left curve is minimum melt, and the right maximum clearing.

The maximum load through the recloser is 230 A. A recloser was selected with a minimum trip rating of 560 A phase, slightly more than twice the load needed to override cold load with a safety factor. The ground unit is set at 280 A by choice. The time characteristics for both units are plotted for the timed and the instantaneous operations from the manufacturer's data.

The maximum load through the breaker and relays at the 13 kV bus is 330 A. Thus, the CT ratio of 400:5 will give a secondary current of $330/80 = 4.13$ A.

Extremely inverse time–overcurrent relays provide good coordination with the fuses and the recloser. Selecting tap 9 provides a phase relay pickup of $9 \times 80 = 720$ A, just over twice the maximum load needed to override a cold load. The ground relay is set on tap 4 by choice. This provides a primary 13 kV pickup of $4 \times 80 = 320$ A. Time settings for the phase and the ground relay provide a CTI of at least 0.2 sec above the recloser. This is satisfactory when the recloser time curves include fault-interruption time.

Fast, instantaneous tripping with reclosing is very useful because approximately 80%–95% of the faults on open-wire circuits are temporary. They are caused primarily by momentary tree contact because of wind, or they may be lightning induced. Frequently, these faults can be cleared and the service restored quickly by deenergizing the line with immediate reclosing.

To provide this instantaneous tripping, phase and ground units can be applied to breakers to supplement the time units. Reclosers have either a fast or slow time–current characteristic, of which only one at a time can be used. Several attempts can be made, usually 1–3. The particular number and sequence is based on many local factors and experiences.

With reference to [Figure 12.4](#), when using $k = 1.2$, the instantaneous unit is set to not operate for fault 2 or the phase at 7357 A and the ground at 6990 A. This is not shown in [Figure 12.5](#), but would be a horizontal line at the relay, and breaker clearing time to the right from the foregoing operating values. In this application, the operating values do not provide a large margin over the maximum fault values for fault 1; hence, only a short section of the line has instantaneous protection. This is still recommended, for it provides fast clearing for the heavy close-in faults.

Fuse-saving is used to avoid fuse operations for transient faults and, thereby, avoid long outages for crews to replace them. This is accomplished by a second instantaneous unit set to overreach the fuse and, in the hope to clear transient faults before the fuse can operate. An instantaneous reclose is attempted and, if successful, service is restored. The instantaneous unit is locked out, thereby permitting the fuse to clear a continuing fault. An industry survey by the IEEE showed that 81% use this for phase faults and 61% for ground faults.

Thus, for fuse-saving at the breaker, as in [Figure 12.4](#), the instantaneous units could be set to operate for fault 2, but not for fault 3, or at 5374 A phase, 4763 A ground ($1.2 \times$ fault 3). However, it is important that the instantaneous unit and breaker clear faults before the fuse is damaged (minimum melt) or blown. [Figure 12.4](#) shows that the 100T fuse will be damaged at about 5000 A after about 0.03 sec (1.8 cycles at 60 Hz). Thus, the fuse will blow before the breaker opens; therefore, fuse-saving is not applicable at the breaker.

Fuse-saving is applicable at the recloser when operating on its fast or instantaneous curves. For faults on the laterals beyond faults 4, 5, or 6, the recloser will trip and reclose once or twice as programmed. If the fault is transient and cleared, service will be restored without a fuse operation. After this, the recloser operates on its slow curves, and the fault is cleared by the proper fuse on the laterals or by the recloser for faults on the feeder.

A sectionalizer could be used for fault 2 lateral circuit instead of the fuse. It would open during a dead period to clear a permanent fault on its circuit after, say, two unsuccessful fault operations by the breaker instantaneous units.

Reclosing can provide a potential liability where the circuit can be physically contacted by persons, such as downed lines at or near ground level. Many years ago, a case was reported where a conductor fell on a pile of lumber and started a small fire. When the power company arrived at the scene they were very surprised to find the wire coiled on the ground near the lumber, but no victim. It appeared that a helpful passer-by had moved the conductor during the dead period between the reclosing cycles; most fortunate, but very risky.

12.6.1 PRACTICAL DISTRIBUTION COORDINATION CONSIDERATIONS

Distribution protection practices will be found to vary considerably between utilities. This is due to the nature of the system being protected, operating experience, and the historical philosophy that has evolved within each individual utility. An area where differences exist is in the application of instantaneous overcurrent relaying. Such application involves judgment in creating a balance between preventing permanent outages for faults that are temporary in nature and subjecting the entire feeder to more momentary outages than necessary. Some utilities have abandoned fuse-saving practices because of the increasing complaints caused by the impact of momentary outages on sensitive electronic equipment. Other utilities maintain an outlook that the advantages of applying “low set” instantaneous tripping to facilitate fuse-savings outweigh the disadvantages. Some such utilities use a low set instantaneous relay on all distribution feeders that are blocked after the first trip, and an additional high set instantaneous relay that is in service at all times. The high set instantaneous relay provides fast clearing for high-magnitude faults, which helps prevent equipment damage and can enhance coordination, allowing for more sensitive settings to be applied on protective devices that are upstream from the line terminal breaker. It should also be recognized that when fuse-saving cannot be obtained for a maximum fault at the fuse location, as illustrated in the previous example, the fuse may still be saved for some faults that are downstream from the fuse or for faults on the tap that may be somewhat restricted. This is significant since overhead line faults are rarely “bolted” and will, in the vast majority of cases, have some restriction at the fault location.

Automatic reclosing plays a very important role in promptly restoring overhead lines to service following a temporary fault. It has been common practice at some utilities to automatically test a distribution line up to three times subsequent to a trip. The first reclosure is typically as fast as possible with about 15 cycles allowed for arc extinction. The second automatic reclosure was set to occur in 15 sec and the third in about 145 sec. It was found that the 145 sec delay on the third reclosure presented a safety hazard, as this relatively long time period was sufficient in some cases for downed lines to be considered completely deenergized and contacted by people in the area prior to the occurrence of the final automatic reclosure. As a result, some utilities have changed their automatic reclosing schedule, such that the third automatic reclosure was removed or set to occur in around 15 sec. System operators must also be alert not to initiate a test of lines when the nature of the failure is not known and the safety of maintenance personnel or the public may be in danger.

The use of programmable microprocessor-based protective devices can be applied to mitigate some of the problems encountered in protecting distribution systems. Such applications are discussed further in [Chapter 15](#). In addition, various techniques have been developed for detecting downed conductors, even when restriction causes practically no fault current to flow. Experience has shown that very little fault current might flow when the conductor falls on hard surfaces such as roads or sidewalks. Devices for detecting downed conductors have been in the experimental stage for a number of years. Reliability issues involved with such devices have caused most utilities to be reluctant to use them to initiate a trip of the circuit. The public safety implications of energized downed conductors remain a serious concern, and efforts to develop more reliable techniques for detecting such conditions are continuing and are warranted. In the meantime, one such approach that has been taken to obtain better sensitivity for detecting ground faults is to apply a ground relay set as sensitive as possible, considering the maximum unbalance that occurs on the circuit and with an extended delay to enable coordination with downstream devices. Automatic reclosing is blocked upon operation of this relay, since a probability of a downed conductor is indicated. Such application is made more practical with modern monitoring systems that allow unbalance to be continually tracked and recorded and with an adaptable setting capability that is available in modern digital relays.

12.7 DISTRIBUTED GENERATORS AND OTHER SOURCES CONNECTED TO DISTRIBUTION LINES

Various types and sizes of power sources are tied to distribution systems to supply power to electric utilities. This area was discussed in [Chapter 8](#), primarily from the generator and inertia perspective.

With the possibility of current for line faults supplied from both the distributed generator (DG) and the utility, the radial line tends to become a loop type for which directional relays might be needed. For [Figure 12.4](#), if a DG is connected to the feeder circuit as shown, a problem may exist for a fault on an adjacent feeder. The DG supplies current to the fault through the feeder, and its nondirectional overcurrent relays on the adjacent feeder. The possibility exists that both the unfaulted DG feeder and the faulted feeder may trip.

However, practically, the DG contribution is often quite small when compared with that from the utility. The large utility contribution requires a high setting, and with very inverse-time-current relay characteristics generally used, the operating time for the low DG contribution through its feeder is very long. Hence, directional-type relays may not be required. However, with increased proliferation of DGs on distribution circuits, this can evolve into a concern over time. Ground current contribution from DGs can also decrease the sensitivity of relaying on the line breaker for detecting ground faults. Protection engineers need to be alert to these concerns.

It is mandatory, as emphasized in [Chapter 8](#) and as repeated in this chapter, that all distributive power sources be promptly disconnected from the utility, whenever there is an interruption between the utility and the nonutility sources. This can be accomplished by undervoltage (27), overvoltage (59), and under-and-overfrequency (81/U, 81/O) relays at the DG units. Instantaneous tripping on overvoltages should be provided, where high voltages can occur because of ferroresonance in an isolated island that includes a generation source. A setting high enough to prevent nuisance tripping is required.

If the utility and its ground source can be separated from an ungrounded DG, the DG and the connected system can operate in an ungrounded mode. A 59N relay connected across the wye-grounded–broken delta should be used for protection.

When a DG can become islanded with part of the utility system, for which it could supply the load, some method of remote tripping of the DG is required. One reason, among many cited in [Chapter 8](#), is that the utility cannot restore its service without potential damage to the DG and connected customers.

Instantaneous, automatic reclosing cannot be used on circuits with DG sources. Reclosing should be done at the utility terminal only on the assurance that the DG is not connected or that synchronization is not required. As is appropriate, the DG unit must be connected or resynchronized to the utility only after assurance that the utility line has been permanently restored.

Specific application for all DG connections must be coordinated with the utility, for each has its own requirements.

12.8 EXAMPLE: COORDINATION FOR A LOOP SYSTEM

Coordination for a loop system is much more complex and difficult. For each fault, the current-operating relays that overreach other relays will be different

from those of the current that operates the overreached relays. This is in addition to the variation in current levels by system operation. Thus, the current overlay technique is very difficult or impossible to use. A coordination chart will be used in the example. Because fault current can flow in either direction through the line, directional-type time-overcurrent relays are required. They may not be required for instantaneous overcurrent units, but they are often used for uniformity and possible future system changes that might make them necessary. The “trip direction” of the directional relays normally is into the line that is protected.

A typical loop system is shown in Figure 12.6, the key faults that are documented for the several breakers at the three buses of the loop for three

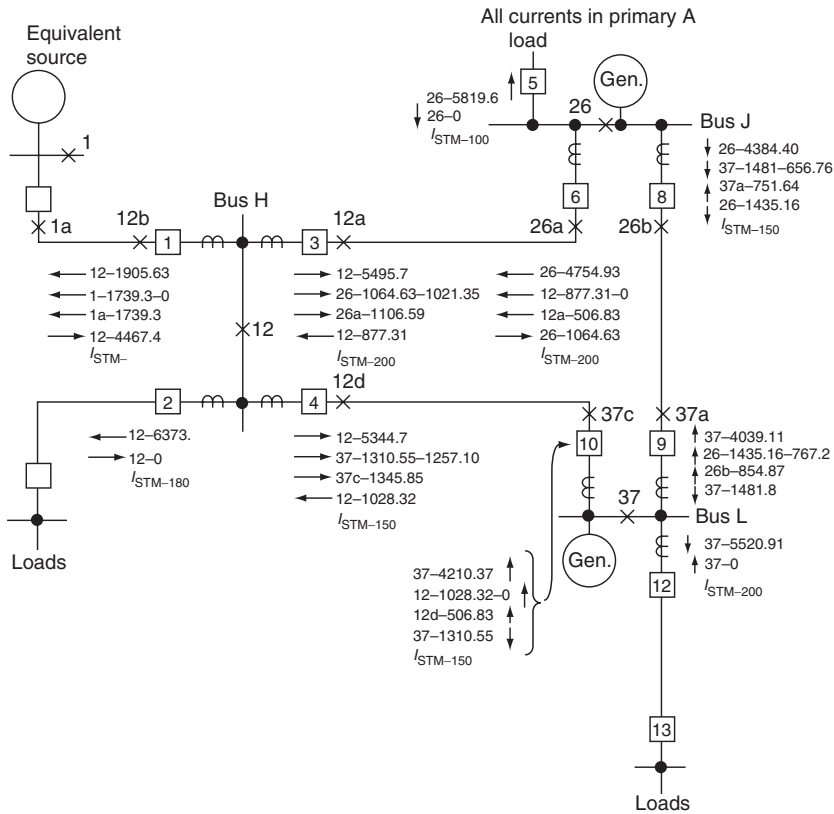

FIGURE 12.6 Typical loop system with multiple sources. Three-phase fault currents at 34.5 kV. First value is the maximum current, second value is the minimum current. The minimum-operating condition considered was the generators at buses J and L of service for light load. The generator-transformer units have fast differential protection.

phase faults. Typical settings will be made for the phase relays. The setting ground relays for the system is similar using phase-to-ground fault data and relay pickup values, as outlined earlier. In general, these taps will be one-half or less of the phase relays taps for most systems.

The directional time-overcurrent relays are applied at breakers 1, 3, 4, 6, 8, 9, and 10, with each directional unit “looking into the line” or operating when current is flowing into the line section.

Around the loop, clockwise:

- Relays at 3 must coordinate with relays at 5 and 8.
- Relays at 8 must coordinate with relays at 10 and 12.
- Relays at 10 must coordinate with relays at 1, 2, and 3.

Around the loop, counterclockwise:

- Relays at 4 must coordinate with relays at 9 and 12.
- Relays at 9 must coordinate with relays at 5 and 6.
- Relays at 6 must coordinate with relays at 1, 2, and 4.

Thus, it is seen that the loops are not completely independent. The settings in both are dependent on the settings of the relays on other circuits (and loops) from the several buses. In the example, these other circuits are the relays at breakers 1, 2, 5, and 12, and the generators at buses J and L. In setting relays around the loop, the first step is to determine the settings and operating times for these relays. To simplify the example, assume that the settings for these are the following:

- *Phase relays breaker 1:* Pilot relays with operating time not exceeding 0.06 sec are used on this short line.
- *Phase relays breaker 5:* Maximum-operating time for fault 26 on the line is 0.24 sec.
- *Phase relays breaker 12:* Maximum-operating time for fault 37 on the line is 0.18 sec.
- *Phase relays breaker 2:* Maximum-operating time for fault 12 on the line is 0.21 sec.

In setting relays around a loop, a good general rule is to attempt to set each relay to operate in less than 0.20 sec for the close-in fault and at least 0.20 sec and the CTI for the far-bus fault. Where the relays protective lines extending from the remote bus have operating times longer than 0.20 sec, the setting should be the sum of that maximum time and the CTI. For this example, a CTI of 0.30 sec will be used.

The relay coordination information for setting the relays around the loop in the clockwise direction, starting arbitrarily at breaker 3, is documented for

convenience in Figure 12.7a. With the short-time maximum load of 200 A, 250:5 CTs can be used. The maximum load is then $200/50 = 4$ A secondary. Select relay tap 6, which is 1.5 times this maximum load and gives a primary fault current pickup of $6 \times 50 = 300$ A.

Typical time–overcurrent relay curves are illustrated in Figure 12.8 for determining the time dial setting for coordination. In Figure 12.7a, relay 3 operating times for fault 26 at the far bus must be at least $0.24 + 0.30 = 0.54$ sec, assuming that relays at breaker 8 can eventually be set to operate for close-in fault 26 at not more than 0.24 sec. For this maximum fault (26), relay

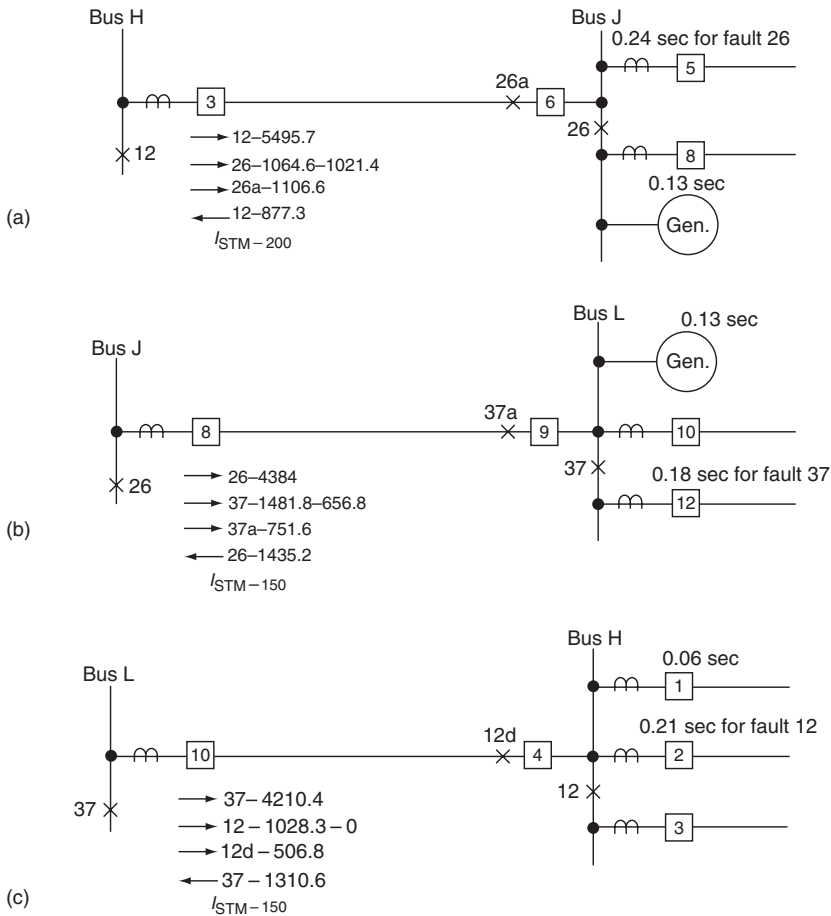

FIGURE 12.7 Information for setting relays for phase-fault protection, clockwise around the loop of Figure 12.6: (a) data for setting breaker three-phase relays; (b) data for setting breaker eight phase relays; (c) data for setting breaker ten phase relays.

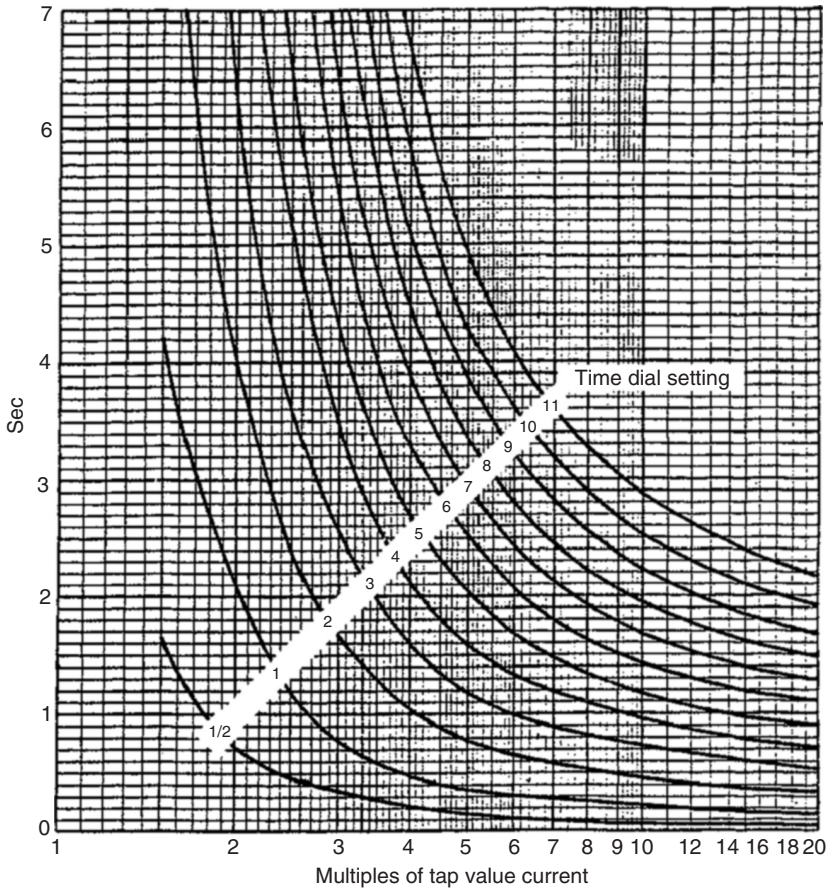

FIGURE 12.8 Typical inverse-time-overcurrent relay curves. (Courtesy of Westinghouse Electric Corporation.)

3 receives 1064.6 A or $1064.6/300 = 3.55$ multiple of its pickup current. From Figure 12.8, a time dial of 1 provides an operating time of 0.58 sec at this multiple, and thus coordination. Relay 3 operating times are for minimum fault 26, 0.61 sec ($1021.4/300 = 3.4$ multiple), maximum close-in fault 12, 0.18 sec ($5495.7/300 = 18.32$ multiple), and minimum line-end fault 26 A, 0.54 sec ($1106.6/300 = 3.69$ multiple). This line-end fault is not a coordination concern, because for it, breaker 6 is open. With directional relays at 3, bus fault 12 is not involved.

At this point move to bus J to set relays at breaker 8. The data are shown in Figure 12.7b. With a 150 A load, 200:5 ratio CTs are suggested. With these, secondary load is $150/40 = 3.75$ A. Tap 5 provides a margin of 1.33 times maximum load and a primary fault current pickup of $5 \times 40 = 200$ A. At this

instance, with relay 3 operating at 0.61 sec minimum for fault 26, from the foregoing, relay 8 should not operate more than $0.61 - 0.3 = 0.31$ sec for fault 26. The time of relays at 10 are unknown, but for the rest at bus L, relay 8 for faults 37 must be at least $0.18 + 0.3 = 0.48$ sec. Maximum close-in fault 26 is 4384 A, to provide a multiple of $4384/200 = 21.9$. For the far-bus fault 37, the multiple is $1481.8/200 = 7.41$. From the time curves (see Figure 12.8), time dial 2 provides 0.35 sec for the close-in fault and 0.56 sec for the far-bus maximum fault. This does not coordinate. Going back to relay 3 and increasing its time dial to 1.5, changes the operating times to 0.25 sec for the close-in fault and 0.85 sec for the far-bus maximum fault. This is 0.5 sec longer than relay 8.

Continuing around the loop to relays at breaker 10, the 150 A load suggests 20:5 CTs, giving a secondary load current of $150/40 = 3.75$ A. Tap 5 provides a margin of 1.33 more than the maximum load, and a primary current pickup of $5 \times 40 = 200$ A. For the close-in fault 37, the relay multiple is $4210.4/200 = 21$. For the maximum far-bus fault 12, the multiple is $1028.3/200 = 5.14$. The limits for relay 10 are shorter than 0.26 sec ($0.56 - 0.30$) for the close-in fault and longer than 0.55 sec ($0.25 + 0.30$) for the far-bus fault. Time dial 1.5 just meets this, thereby providing coordination.

Numbers are confusing, so the coordination around the loop is summarized in Figure 12.9. The relays at bus H are repeated to show coordination. The times in parentheses are the operating times for the far-bus minimum fault and the line-end fault. With the generators out of service at both buses J and L for the minimum condition, no current flows through breakers 10 and 6 for far-bus faults. This changes after the far-bus relay 4 or 3 opens, which provides fault current per 12d and 12a, respectively, the line-end faults. It is important to ensure that the relays can respond to these line-end faults; otherwise, they cannot be cleared.

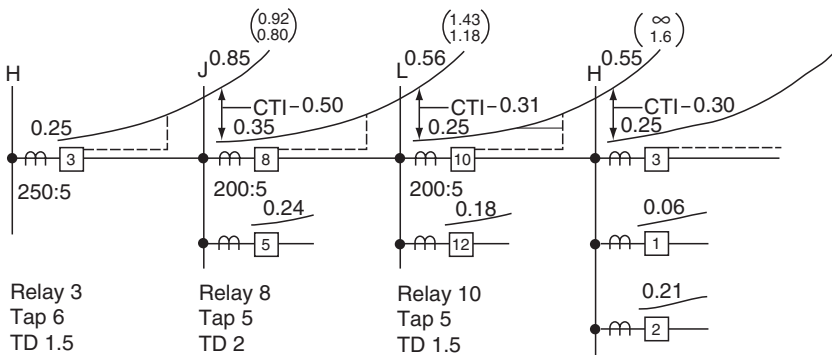

FIGURE 12.9 Summary of the phase relay settings around the clockwise loop of the Figure 12.6 system. The dashed horizontal lines represent instantaneous overcurrent protection.

The loop for this minimum-operating condition becomes a single-source loop. Although most distribution systems are radial, some are of this single-source loop type. It is also used in industrial plant complexes where there are several separate load areas. The advantage is that any one-line circuit can be removed with service available to all the loads. In this type of system, where the source is at bus H only (see Figure 12.6), the relays at breaker 6 do not need to coordinate with the relays at 1, 2, and 4, because they do not have current for fault 12. Similarly, relays at 10 do not need to coordinate with relays at 1, 2, and 3. Faults on the lines, such as at 12a and 12d, can be detected only after breakers 3 or 4, respectively, have opened when the fault current of the line-end fault exists. Thus, these faults are “sequentially cleared.” Load current into these lines would also be zero, unless there are other line taps. As a result, direction instantaneous relays can be applied at breakers 6 and 10 and set very sensitively and below the values for line-end faults. This provides “high-speed sequential operation” for these terminals. The next phase in the coordination process for the loop example is to set relays 4, 9, and 6 counterclockwise around the loop. This will not be continued, as the basic principles have been covered.

In most actual systems, attention must be given to the possibilities of various lines out of service and other operating conditions that may occur. It would be desirable to set all the relays to provide complete backup protection over all the adjacent remote lines. In the example, this would be to have the relays at breaker 3 provide protection for faults to bus L and out on load line 5 to any sectionalizing point. This may or may not be possible. The “infeed” of fault current by the source at bus J tends to reduce the fault current through 3 for faults on line JL and at bus L.

The computers that provide fault data for many variables and operating conditions also provide an excellent tool for setting and coordinating relays. Several such programs exist with varying degrees of capability and sophistication, and others are developed. These can be of great value in reducing the time and the drudgery of hand coordination, and often consider more alternatives and conditions than would otherwise be convenient.

12.9 INSTANTANEOUS TRIP APPLICATION FOR A LOOP SYSTEM

When a reasonable difference in the fault current exists between the close-in and far-bus faults, instantaneous units can be used to provide fast protection for faults out on the line. The fundamentals were outlined in Section 12.4.3. For the example of Figure 12.6 and using Figure 12.7, instantaneous unit at relays 3 must be set at k times the maximum far-bus fault current of 1064.6. Using $k = 1.2$, the setting would be 1277.5 A or 1278 A. This gives good coverage for the line compared with the close-in fault of 5495.7 A. The

percentage coverage is not linear on a loop system as it would be on a radial line, where the coverage would be

$$\text{Percentage instantaneous coverage} = 100 \left(\frac{I_{CI} - I_{IT}}{I_{CI} - I_{FB}} \right), \quad (12.1)$$

where I_{CI} is the close-in fault current, I_{FB} the far-bus fault current, and I_{IT} the instantaneous unit setting current. Thus, for the loop the coverage will be less than the value of

$$100 \left(\frac{5495.7 - 1278}{5495.7 - 1064.6} \right) = 95.2\%,$$

possibly about 85%–90%. Because the setting of 1278 is greater than the reverse or near-bus current of 877.31, a nondirectional instantaneous unit can be used. However, directional unit is required at the opposite end, at breaker 6, unless I_{IT} is set above $1.2 \times 1065 = 1278$ A.

For breaker 8 at bus J, set the instantaneous unit at 1.2×1481.8 , or 1778 A, and a nondirectional type is applicable.

For breaker 9, set the instantaneous unit at 1.2×1435.2 , or 1722 A. Because the near-bus current is 1481.8 A and slightly larger than the far-bus current, a nondirectional type might be used, for the value is lesser than the setting. However, the margin for transients and errors is less, so a directional type should be considered.

For breaker 10, set the instantaneous unit 1.2×1028.3 , or 1234 A. This must be a directional type, for the near-bus current is 1311 A. A nondirectional type with a setting of 1.2×1310.6 , or 1573 A, could be applied with good coverage of the line.

These instantaneous trip units supplement the time–overcurrent protection to provide fast operation over part of the line sections. They are shown as dashed-lines on [Figure 12.9](#).

Often, these units do not reach as far as was possible in the example, and occasionally offer limited protection for the maximum fault condition and none for minimum faults. Thus, their application becomes marginal from a protection coverage standpoint. Still, they can provide fast clearing for the heaviest close-in faults.

The operating times of the time–overcurrent relays can be reduced with instantaneous units by coordinating at their pickup point, rather than at the far bus. In other words, the CTI for relay 3 (see [Figure 12.9](#)) would be used at the instantaneous pickup point, the vertical dashed line to the right of 8. This becomes more difficult when the instantaneous unit reach varies considerably with fault-level changes from system changes. This can be programmed into the computer relay setting programs.

12.10 SHORT-LINE APPLICATIONS

As discussed in Section 12.1, short lines having a high SIR are low in miles or kilometers, but are better defined electrically for overcurrent protection purposes by considering the relative values of the close-in (CI) and far-bus (FB) fault currents. Figure 12.10 shows these two faults. A short line is when Z_L is low compared with the source impedance Z_S . Then I_{CI} almost equals I_{FB} , and current magnitude differences between the two faults do not provide a good indication for fault location. For a long line, Z_L is large relative to Z_S , to provide a significant and measurable difference between the two faults.

Thus, for the short lines, essentially fixed time discrimination must be used to coordinate between the relays at bus G and those at bus H. On a radial feeder, this means that the operating time is the largest nearest to the source end and the least at the load end.

On the loop systems, coordination is possible, only where a significant magnitude difference exists between the close-in and the far-bus faults around the loop. If the difference does not provide the means of fast clearing for close-in faults and delayed tripping for far-bus faults, coordination around a loop is impossible. In these cases, pilot protection, quite often differential protection, must be used for the primary protection. This type is discussed in Chapter 13.

Time-overcurrent relays can be used for backup protection, recognizing that they will not coordinate somewhere around the loop. This point of miscoordination should be selected at (1) a point of least probable fault incident, or (2) a point in the system where the minimum system disturbance would result, or (3) both. With highly reliable pilot protection, the backup would seldom be called on for protection.

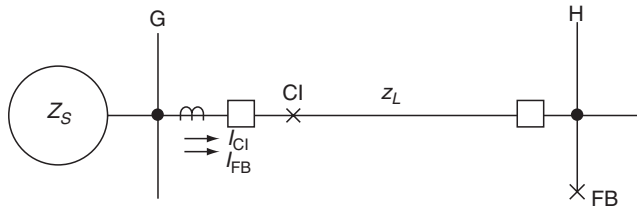

For three-phase faults:

$$I_{CI} = \frac{1}{Z_S}$$

$$I_{FB} = \frac{1}{Z_S + Z_L}$$

FIGURE 12.10 Close-in and far-bus faults on line Z_L defining short lines versus long lines.

12.11 NETWORK AND SPOT NETWORK SYSTEMS

High-density load areas, such as those that exist in major metropolitan areas, commercial buildings, and shopping centers, are served by a low-voltage grid network supplied from at least two relatively independent supply sources. LTNs that supply business districts of larger cities are supplied from a large number of network transformers that are connected to multiple distribution circuits. LTNs are highly reliable and designed to be capable of withstanding multiple outages on its supply system without overloading. The secondary network is operated at a low voltage (i.e., 120/208 V), suitable for direct supply to customers. Faults on the secondary network result in very high-fault current values and are self-clearing since, at such low voltage, arcs cannot be sustained in air. Faults on the network, therefore, burn free and do not require operation of any interrupting device. Spot networks are unit substations with two step-down transformers, with primaries connected to separate power sources. In both types, the secondaries are connected through circuit breakers or network protectors into the secondary grid. The protection is built into the protectors for automatically (1) disconnecting the supply transformer or circuit from the secondary network for faults, (2) opening the circuit when the supply or source voltage is lost, and (3) closing when the source is restored and the system source and network voltages are within designated limits. These are highly specialized areas of design and protection, and beyond the scope of this book.

12.12 DISTANCE PROTECTION FOR PHASE FAULTS

The basic characteristics and fundamentals of distance relays have been covered in [Chapter 6](#). This type of protection is applied almost universally for phase protection of lines at 69 kV and higher. The mho characteristic of [Figure 6.13b](#) is used most commonly. The major advantages are (1) fixed reach as a function of the protected line impedance and so independence of system operating and fault levels over a very wide range, (2) ability to operate for fault currents near or less than maximum load current, and (3) minimum to no transient overreach. They are more complex and costly than overcurrent relays. They are applicable at the lower voltages, but are not widely used except for special problems, such as load and fault current magnitudes close together. This could change with the advent of microprocessor units.

A minimum of two zones are necessary for primary protection because of the impossibility of determining if the far-bus fault is within or is outside the line section. Both zones operate instantaneously, but one (zone 2) is delayed by the CTI, to provide coordination. A fixed timer T_2 is used. It has been customary over many years to apply a forward third zone to provide backup protection for the remote line(s).

The common practice in the United States has been to use separate distance units for the several protection zones. This is in contrast with distance relays that use a single distance-measuring unit initially set for zone 1 reach. If the fault persists, the reach is extended by switching to zone 2 Ω after T_2 time delay, then after T_3 to zone 3 Ω . Both designs provide good protection. Separate units provide the comfort of redundancy because, for faults in the zone 1 primary reach area, all three distance units will operate. Thus, zones 2 and 3 are backup for failures of zone 1 unit. The switched types do not provide this backup, but are more economical.

These zones and typical settings are illustrated in Figure 12.11. Figure 12.11a shows the zones at several locations. Typically, zone 1 is set for 90%

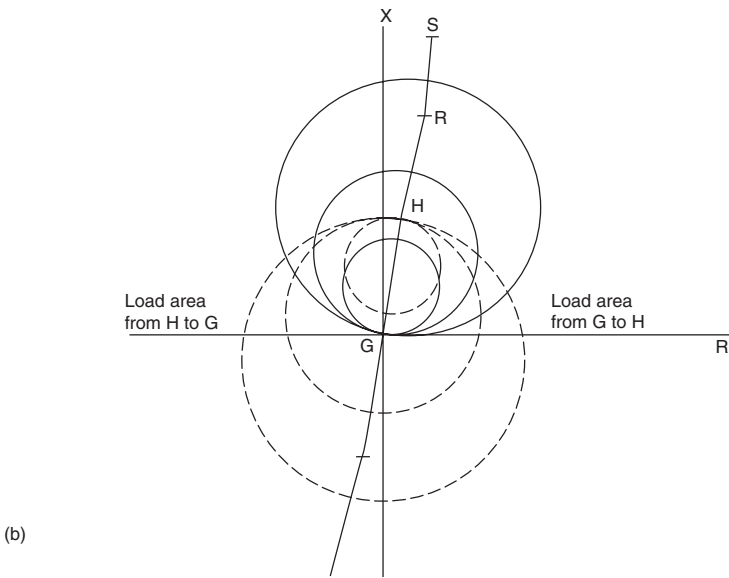
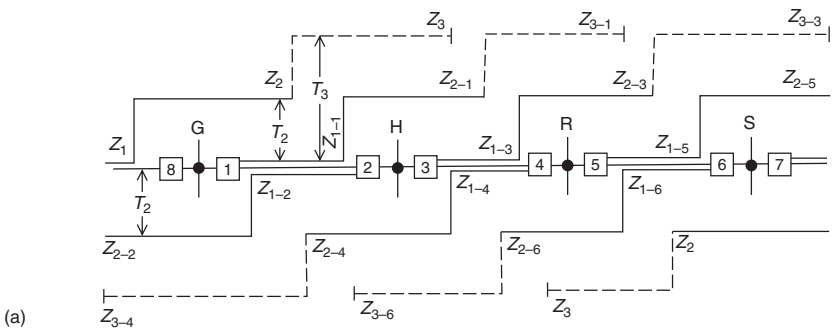

FIGURE 12.11 Protection zones with distance relays: (a) time–distance plot; (b) R–X diagram plot.

(range 85%–95%) of the positive-sequence line impedance, zone 2 approximately 50% into the next adjacent line, and zone 3 approximately 25% into the adjacent line beyond. Where possible, zones 2 and 3 provide backup for all the adjacent lines at operating times of T_2 and T_3 .

Figure 12.11b shows the operating circles for the three zone at bus G, breaker 1 (solid line) and at bus H, breaker 2 (broken line), plotted on the R – X diagram. The several lines are shown at their respective $r + jx$ positions. The relays operate when the ratio of fault voltage to current falls within the circles. Load impedance (see Equation 6.2) normally falls in the general areas shown.

On long lines, where large mho operating circles can include the load areas, the restrictive characteristics illustrated in Figure 6.13c, Figure 6.13d, Figure 6.13e are used. They provide a long reach in the fault area, with quite a restricted reach in the load areas.

The operating circles must be set such that they do not operate on any system swings from which the system can recover. Such swings occur after a system disturbance, such as faults, sudden loss of generation or load, or from switching operations. This is discussed later. These swings may also require application of the restricted operating characteristics.

Zone 1 at each end of the line provides the most desirable protection—simultaneous high-speed operation for the middle 80% of the line section. This can be increased to 100% only with pilot relaying.

Backup protection, as suggested in Figure 12.11, is ideal and seldom obtainable. In practice, most buses have multiple lines of different lengths and with power source at their remote ends. A typical example is illustrated in Figure 12.12. The relays at breaker 1, bus G protecting line GH look into lines HR and HS extending from bus H. Where line HR is short and line HS is long, zone 2 set for 50% of line HR will cover only a small percentage of line HS. Setting for 50% of line HS would result in possibly overreaching and miscoordinating with Z_2 of line HR, unless T_2 time was increased. This problem is multiplied with other lines of different length extending from bus H. However, the reach will not be as far as indicated because of the “infeed

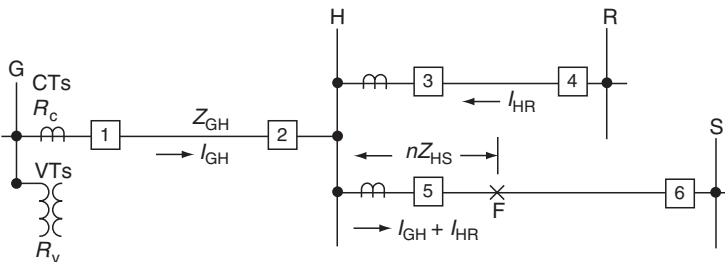

FIGURE 12.12 Protection for multiple lines and infeed at a remote bus.

effect.” Fault current from other lines will cause relays at 1 to underreach. This effect can be seen by considering a solid three-phase fault at F. With $V_F = 0$, the relays at 1 receive current I_{GH} , but the bus G voltage is the drop $Z_{GH}I_{GH} + nZ_{HS}(I_{GH} + I_{HR})$. Thus, the relays at 1 “see” an apparent impedance of

$$\begin{aligned} Z_{\text{apparent}} &= \frac{Z_{GH}I_{GH} + nZ_{HS}(I_{GH} + I_{HR})}{I_{GH}} \\ &= Z_{GH} + nZ_{HS} + \frac{I_{HR}}{I_{GH}}(nZ_{HS}). \end{aligned} \quad (12.2)$$

This is a larger value by the third term, $I_{HR}/I_{GH}(nZ_{HS})$, than the actual impedance, which is

$$Z_{GH} + nZ_{HS}. \quad (12.3)$$

As a result, relay 1, when set to a value of the actual impedance of Equation 12.3, would not see fault F; in other words, relay 1 “underreaches” as a result of the fault contributions from other lines, connected to bus H. Setting of the relays for the apparent impedance value has the danger of overreaching and miscoordination when the infeeds are removed or changed by system operation.

The infeed term can be quite large and also variable when a large part of the current fault is supplied by other circuits. The relay underreach will approach the remote bus, but not quite reach it, so primary protection is not inhibited. This is true for a two-terminal line without infeed taps, such as that shown in [Figure 12.12](#).

Undesired operation of zone 3 distance relays, applied for remote backup protection during major system disturbances, has caused the magnitude of the scope of such disturbances to be expanded. Large ohmic settings had been typically applied to the zone 3 relaying, in order to obtain the desired backup protection. Power swings and low voltage conditions that often exist during system disturbances resulted in the impedance seen by the zone 3 relay to be within its operating characteristic for a sufficient length of time for it to initiate a trip command. Such experiences have resulted in utilities restricting the use or reach applied to zone 3 relaying.

12.13 DISTANCE RELAY APPLICATIONS FOR TAPPED AND MULTITERMINAL LINES

Examples of single-tapped lines are shown in [Figure 12.13](#) and [Figure 12.14](#). Some lines have multiple taps (3 or 4). Although these may be economically, or physically, necessary they are always more difficult to protect. To provide

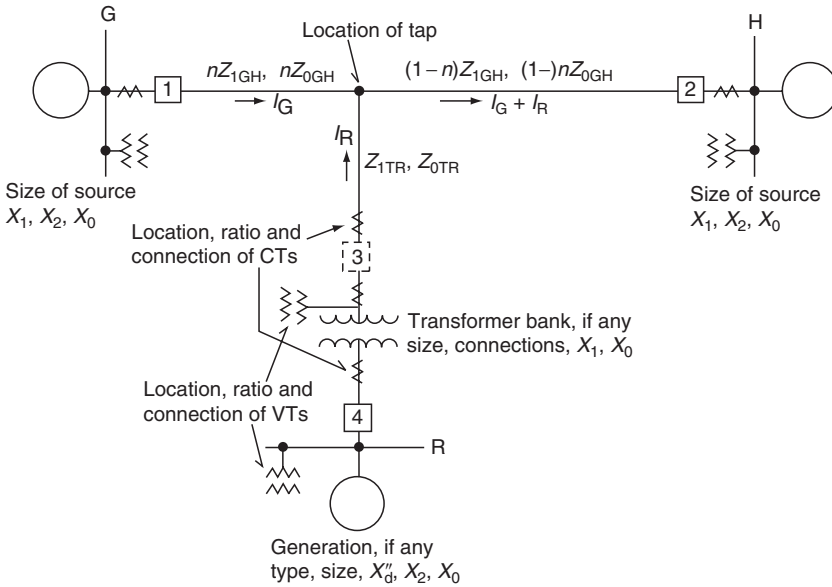

FIGURE 12.13 Typical tapped line and information required for a protection study. Currents are for a fault at bus H.

protection, considerable information is required, such as the type of tap(s) (see Figure 12.13 or Figure 12.14). If the taps are of the Figure 12.13 type, then beyond the normal information for the two-terminal lines, the information outlined on the figure should be supplied or obtained. If a wye–delta transformer bank is included as part of the tap, information that shows how the bank is grounded is required. Amazingly, this information is very frequently omitted from station one-line diagrams.

Consider the line of Figure 12.13; the tap T may be a transformer at or near the line, so that Z_{TR} would be the sum of the impedance from the tap and the transformer bank impedance. Sometimes, the tap ties through Z_{TR} to a bus, as shown in the figure. The tap may serve a load, so that negligible fault

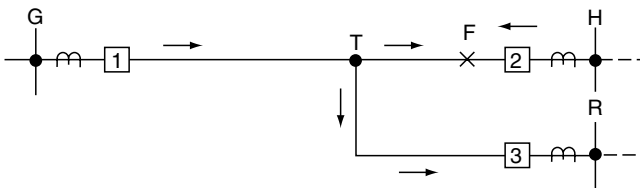

FIGURE 12.14 Multiterminal line where fault current can flow out at one terminal for internal faults.

current is supplied through it to line faults, or it may tie into a fault source at R, as shown by the broken line. Another variation is illustrated in [Figure 12.14](#).

The fundamentals for setting distance relays on these types of lines for primary phase-fault protection are as follows:

1. Set zone 1 for k times the lowest actual impedance to any remote terminal for Figure 12. 13-type circuits, or for k times the lowest apparent impedance to any remote terminal for the special case of Figure 12.14, k is less than 1, normal 0.9.
2. Set zone 2 for a value greater than the largest impedance, actual or apparent, to the remote terminals.
3. The zone 2 time (T_2) must be set such that it does not cause misoperation when any terminal is out of service and, thereby, causes the distance unit to overreach.

For example, assume the high-side breaker 3 exists at the tap; therefore, distance relays would be applied using the high-side CTs and VTs at the tap. For a fault at bus H, the actual impedance from the high side of the tap to bus H is

$$Z_{R \text{ actual}} = Z_{1R} + (1-n)Z_{1GH}, \quad (12.4)$$

but with current from station G to the fault at H. The tap relays sees

$$Z_{R \text{ apparent}} = \frac{Z_{1R} + (1-n)Z_{1GH} + I_{1G}}{I_{1R}(1-n)Z_{1GH}} \quad (12.5)$$

when I_{1G}/I_{1R} is large, which would be with a small tap source where I_{1R} is very small relative to I_{1G} , $Z_{R \text{ apparent}}$ can be quite large requiring long Z_2 , Z_3 settings. When breaker G is out of service or breaker 1 at G opens Z_2 , Z_3 can overreach considerably. This can result in zone 2 and zone 3 backup being impracticable or requiring extended times.

For some arrangements of circuits, these requirements can make primary protection quite difficult or limited. In [Figure 12.13](#), consider that tap T is very near bus G, so nZ_{GH} is small and $(1-n)Z_{GH}$ is large with Z_{TR} very small. Then zone 1 at breaker 1, bus G must be set at 90% of $(nZ_{GH} + Z_{TR})$, which is a very small value compared with $(1-n)Z_{GH}$. Thus, high-speed coverage of the line is almost negligible.

On the other hand, if the tap is a load transformer where Z_{TR} is high relative to Z_{GH} , zone 1 at breakers 1 and 2 can be set for 90% of the line to provide good high-speed line protection.

If R is a load tap in [Figure 12.13](#), with negligible current to line faults, distance relays (and overcurrent) are not applicable at breaker 3, and basically

are not necessary, for opening breakers 1 and 2 terminates the line fault. The worst case is a small generator or source connected to R , large enough to maintain a fault on the line, but not large enough to support fault-detecting relays. In other words, the impedance to a line fault from bus R is very large and approaches infinity.

For the example in [Figure 12.14](#), current can flow out of the R terminal for an internal line fault near the H bus. Thus, distance or directional relays at breaker 3 see the internal fault as an external one for no operation until after breaker 2 has opened.

Consequently, protection of tapped and multiterminal lines is more complex and requires specific data on the line impedances, location and type of tap or terminal, and fault data, with current distributions for the various system and operating conditions. Most often, except for small transformer load taps, these types of lines are protected best by pilot relaying.

12.14 VOLTAGE SOURCES FOR DISTANCE RELAYS

Three-phase voltage is required and provides reference quantities with which the currents are compared. For phase distance relays, either open-delta, or wye–wye voltage transformers (VTs), or coupling capacitor voltage devices (CCVTs) can be used and connected either to the used line or to the line that is protected. Both are widely used, and the decision is economic as well as involving use of line-side CCVTs for radio-frequency coupling for pilot or transfer trip relaying.

These voltage sources involve fuses—primary and secondary for VTs and secondary for CCVTs. These fuses should be generously sized, carefully installed, and well maintained, as a loss of one or more phase voltages may result in an undesired, unwanted relay operation. Where this is of great concern, overcurrent fault detectors can be added to supervise the trip circuit of the distance relays. For loss of voltage in the absence of an actual fault, overcurrent units would not operate. The disadvantages are the need for additional equipment and the loss of the feature of distance relays operating for fault levels less than maximum load.

Recently, detectors measuring V_0 , but not I_0 , have been used to supervise the relays. This requires wye-grounded–wye-grounded voltage sources.

12.15 DISTANCE RELAY APPLICATIONS IN SYSTEMS PROTECTED BY INVERSE-TIME-OVERCURRENT RELAYS

Zone 1 distance relays can be applied to provide increased instantaneous protection over that obtainable by instantaneous overcurrent relays. This is especially helpful when there is a large variation in fault level because of

system and operating changes. Distance relays can provide almost 90% instantaneous coverage of the line section, independently of system and fault-level changes.

To coordinate with existing inverse-time characteristics, a zone 2 distance relay can be set into or through the adjacent line section, with an inverse-time–overcurrent relay as a timer. The distance relay torque controls the overcurrent units; that is, the overcurrent relay cannot operate until the distance relay operates. This permits setting the overcurrent relays below maximum load. Hence, this application is valuable where fault and load currents are close together, or the maximum possible load is greater than minimum fault current.

12.16 GROUND-FAULT PROTECTION FOR LINES

The setting and coordination procedure for ground relays, both inverse-time–overcurrent and instantaneous overcurrent, is the same as that discussed earlier for phase relays. Ground relay taps for the inverse-time units must be set above the tolerable zero-sequence unbalance on the line, and single-phase-to-ground fault data are used. These relays are connected to operate on zero-sequence current from three paralleled CTs or from a CT in the grounded neutral.

In distribution, industrial, and commercial systems, in which line fuses are used, the ground relays receiving $3I_0$ must coordinate with fuses receiving line I_a , I_b , and I_c currents. Although the line current is equal to $3I_0$ in radial feeder circuits, fuses must be set at values higher than the load and a short-time inrush. This may require a high tap setting on the ground relays. The example of [Section 12.6](#) discussed ground relay applications in these types of circuits.

For subtransmission and transmission lines, generally 34.5kV and higher, the systems are usually solidly grounded at many of the stations; thus, they are multigrounded systems. The system unbalance at these levels tends to be quite low. Fuses are not used in the lines; therefore, separate ground relays can be set very sensitively relative to phase relays. In this area, either ground distance or ground–overcurrent relays are employed.

12.17 DISTANCE PROTECTION FOR GROUND FAULTS AND DIRECTION OVERCURRENT COMPARISONS

Ground distance relays have not been in wide use in the United States in the past. This seems unusual in view of the common application of distance relays for phase faults and that most faults (80–90) involve ground. However, the electromechanical ground distance protection units were more complex than phase units, but microprocessor types have simplified this, and these modern ground distance units appear to be more applicable and in wider use.

Directional ground–overcurrent relays usually provide quite sensitive and satisfactory ground–fault protection on multigrounded systems and are in wide use. Load current is not a problem and, on transmission lines, settings of 0.5–1.0 A with 5 A CTs are common.

A brief review of measuring zero-sequence line impedance has been covered in [Section 6.6](#). V_0/I_0 does not provide a suitable indication of the fault location, so various means must be taken to provide the measurement and operation for single-phase-to-ground faults. Although these units may be set using positive-sequence impedance, the ratio between X_0 and X_1 must be programmed. Unfortunately, zero-sequence line impedance is not as accurate as the positive-sequence impedance because it involves variables and unknowns in the earth return impedance, tower impedance, tower footing, and fault (arc) resistances. Consequently, ground distance relays have the advantage over instantaneous overcurrent of a relatively fixed reach, as their zone 1 is set for 80%–85% of the line, compared with 90% for phase distance relays. This reach is affected by mutual impedance, but this is rarely a serious problem for zone 1. The effect of mutual impedance was discussed earlier in the chapter.

Ground reactance relays have long been promoted for improved coverage of fault resistance, especially on short lines. However, fault resistance, as seen by distance-type relays, is not a pure resistance, except on a radial line or at no-load on the line. With load flowing, the out-of-phase infeed to line faults from the remote terminal(s) can produce a very large apparent out-of-phase impedance. This is further discussed in [Section 12.18](#) and illustrated in [Figure 12.15](#). A large apparent impedance can result in failure to operate or misoperation of relays in adjacent sections.

Fault arcs generally appear to be either a “mole hill” (negligible) or a “mountain” (very difficult to protect). There have been many correct operations of ground distance relays because fault arcs were small on transmission lines (mole hills). However, there have been several HV and EHV lines with midspan tree faults (mountains), for which the ground distance relays did not respond properly. In several instances, these faults were cleared by ground–overcurrent relays in adjacent lines. Thus, ground distance protection should be supplemented with directional overcurrent ground relays.

The advantages for overcurrent relays are (1) relative independence of load, (2) generally of larger margin between the close-in and the far-bus faults because the X_0 value of lines is close to three times X_1 , (3) low system unbalance, (4) fuses not used in the lines, and (5) current level for ground faults tends to be more constant than for phase faults, because ground source transformers are seldom switched.

Perhaps the most important reason for the general use of overcurrent relays for ground protection is the general practice of using pilot protection on lines of 115 kV and higher. As has been indicated, the ideal protection is high-speed simultaneous operation at all terminals for 100% of the line faults.

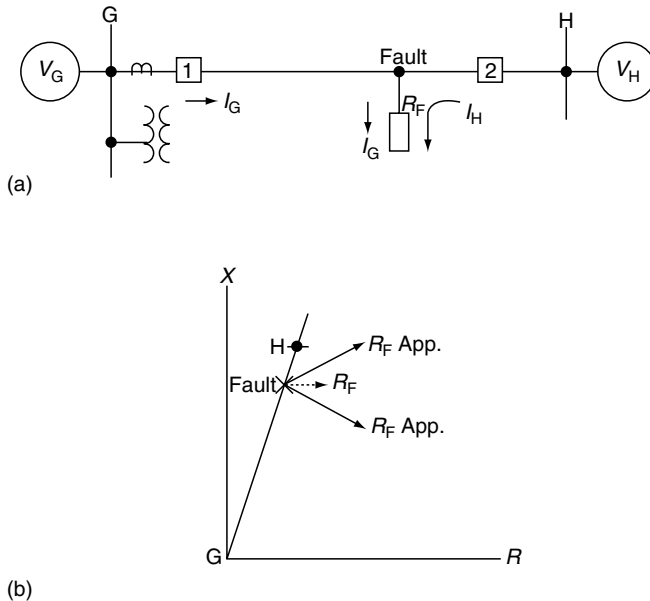

FIGURE 12.15 Typical line and representation of fault impedance: (a) single line diagram; (b) representation on R - X diagram.

Pilot relaying provides this possibility. Ground distance relays provide high-speed simultaneous protection for only the middle 60%–70% of the line. Ground-overcurrent relays are usable and provide quite sensitive protection in the most widely applied pilot systems.

12.18 FAULT RESISTANCE AND RELAYING

Ground faults on lines usually result as flashover of the insulators caused by lightning induction or failure of the insulators. The current path for ground faults include the arc, tower impedance, and the impedance between the tower foundation and the earth (tower footing resistance). When used, ground wires provide a parallel path to the earth return. Phase faults on lines are often the result of high wind swinging the conductors close enough to arc over.

The possibility of significant fault resistance thus exists, with the potential of affecting or inhibiting relay performance. Arcs are resistance, tower and ground wires are complex impedances, and tower footing impedance is essentially resistance. The resistance of arc between 70 and 20,000 A has been expressed as

$$R_{\text{arc}} = \frac{440 \times I}{I} \Omega, \quad (12.6)$$

where l is the arc length in feet and I is the current in the arc. This can be used as R_F in Figure 4.12 through Figure 4.15. Actual arcs are variable, tending to start at a low value, build up exponentially to a high value, and then the arc breaks over, returning to a lower value of resistance. A typical value of 1 or 2 Ω exists for about 0.5 sec, with peaks of 25–50 Ω later. Tower footing resistance at various towers can run from less than 1 Ω to several hundred ohms. With so many variables, it is quite difficult to represent fault resistance with any degree of certainty or realistically.

It has been a common assumption that the fault impedance is all resistance and so can be represented on an R – X diagram as a horizontal value, such as that shown dotted in Figure 12.15b. With this concept, the reactance characteristic, as shown in Figure 6.13f, has been promoted as excellent coverage for large values of R_F and to provide more protection than a circular characteristic such as the mho type. If the arc drop is really a major factor, this document on the R – X diagram is correct only for a radial feeder where distance relays are seldom used, or for an unloaded loop line. However, loop lines generally are carrying load, so that V_G and V_H are not in phase. Real power across a circuit, such as GH, is transmitted by the angular difference between the source voltages. Thus, when a fault occurs, actual currents supplied from the two ends are out of phase. Thus, for relays at breaker 1, station G, the voltage drop measured includes the $I_H Z_F$ drop, which is not compensated because only I_G flows through the relay. Thus, relay 1 sees (1) a higher impedance than the actual impedance of the line and Z_F and (2) an apparent reactive component even if Z_F is only resistance. As a result, R_F will appear as shown, either tilted up when V_H leads V_G , or tilted down when V_G leads V_H . Looking from H toward G, relay H will see a higher impedance when V_G leads V_H , and a lower value when V_H leads V_G .

Thus, if V_G leads V_H in Figure 12.15, so that the higher apparent value of R_F tilts downward, it is quite possible that an external fault in the system to the right of bus H will have this value of R_F fall into the operating area of the zone 1 reactance unit at G. Unless the reach of the G zone 1 reactance unit is reduced, this unit will overtrip incorrectly. Hence, the mho unit will not overreach for all practical operating conditions that have been studied. Although the mho type characteristics may provide less coverage, it is more secure.

The tilt of the apparent R_F upward will prevent operation for both types of characteristics for faults near the setpoint. At worst, the underreach by the tilt and larger magnitude could delay operation of zone 1 until after breaker 2 at bus H opens for faults near the setpoint. Then R_F becomes almost horizontal and lower in value. Zone 2 and 3 units provide additional backup. With pilot relaying, fault resistance seems to be of less importance, because the overreaching units can operate on most values of impedance practically encountered. The one exception is tree faults on EHV lines, mentioned earlier.

The modern practice of minimum right-of-way trimming has resulted in arcs of 100 Ω , or more, on EHV lines as the trees grow into the voltage

gradient breakdown zone. This usually results during heavy-load periods when the midspan line sag is maximum. These are difficult to detect. The best possibility is detection by sensitive ground–overcurrent relays. Distance relays are generally insensitive to these faults. The tree problem is minimized by proper maintenance of the rights-of-way; however, overcurrent protection is still recommended. High-speed clearing for such highly restricted faults is not critical, since the associated fault current levels are low and do not pose a significant threat to equipment or system stability.

12.19 DIRECTIONAL SENSING FOR GROUND–OVERCURRENT RELAYS

For multigrounded loop systems, inverse-time–overcurrent units are directional. Instantaneous units may or may not need to be directional, depending on the relative magnitude of the maximum near-bus and maximum far-bus fault currents. The criteria are given in [Section 12.4.3](#). Generally, separate directional units are used to torque control the fault-detecting overcurrent units or their equivalent in electronic relays. A reference quantity is required with which the various line zero-sequence currents can be compared, to determine if the line current is flowing into the line (tripping direction) or out of the line into the bus (nontripping direction). This reference is known as the polarizing quantity. Zero-sequence current or voltage, or negative-sequence voltage and current, is used for polarizing and directional sensing.

The most common type is current polarization that uses $3I_0$ from a CT that is connected in the grounded neutral of a two-winding wye–delta power transformer. The transformers are as shown in [Figure A4.2-1a](#) and [Figure A4.2-1b](#). Voltage polarization uses $3V_0$ across a grounded wye–delta voltage transformer, as shown in [Figure 4.4](#).

None of the other two-winding transformer bank connections in [Figure A 4.2-1](#) can be used for current polarization, as zero-sequence current cannot pass from the N_0 bus to any system fault through the transformers.

With the three-winding transformer banks of [Figure A4.2-3](#), a single CT in the grounded-wye–neutral of diagrams a and c can provide polarizing similar to the grounded wye–delta two-winding banks. For type b banks, CTs with ratios inversely proportional to the voltage ratio and connected in parallel can be used. The connections are shown in [Figure 12.16](#). This provides polarization for the ground relays on both the high (H) and the low (M) systems. For ground faults in the high-voltage (H) system, zero-sequence current flows up the left-hand neutral and is equal to the sum of the current from the low-voltage (M) system, which flows down the right-hand neutral and circulates in the tertiary (L winding). For ground faults in the low-voltage (M) system, zero-sequence current flows up the right-hand neutral and is the sum of the high-voltage (H) current down the left-hand neutral and the current circulating in the tertiary (L winding). On a per-unit basis, the net current

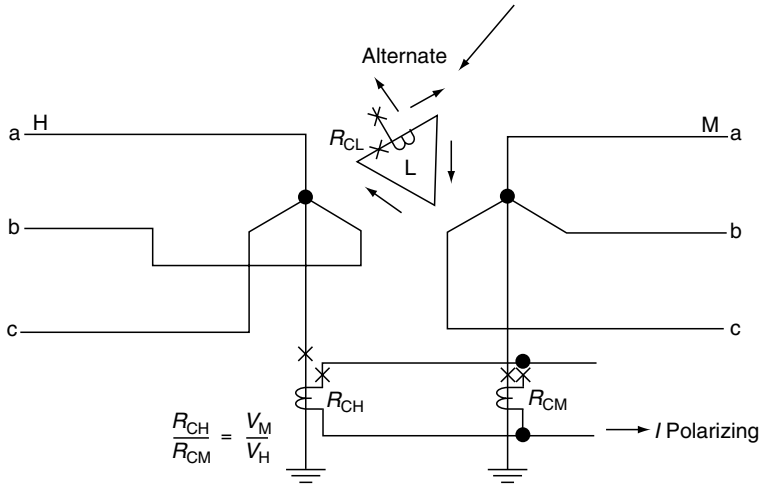

FIGURE 12.16 Ground relaying, directional polarizing from a three-winding transformer bank.

from the paralleled CTs is always in the same direction and equivalent to that circulating in the tertiary. An alternative to the two paralleled CTs is to use a single CT inside the tertiary, as shown. Usually, this tertiary CT is not available unless specified.

It is very important to ensure that the polarizing CTs do not saturate on heavy faults very near the station. In Figure 12.16, the inverse into required can result in a low ratio on one side with low CT capability and potential saturation.

In addition, problems have resulted in paralleling neutrals of different transformer banks for which the grounds are tied to the ground mat at different locations. The voltage difference across the mat can cause CT saturation.

There have been several instances of misoperation, resulting in phase shifts and wave distortion, by the saturation of one or more of the neutral CTs. Even with the low burdens of solid-state relays, long lead lengths can cause CT saturation problems. Good quality neutral CTs are most important so that when it is necessary to use a low ratio, the CT still has a close rating capability.

12.20 POLARIZING PROBLEMS WITH AUTOTRANSFORMERS

The neutral of the autotransformer is seldom usable for polarizing. For a grounded neutral autotransformer without tertiary, zero-sequence current passes through the autotransformer, and the current in the neutral reverses for faults on the two sides. Thus, the neutral is not suitable for polarizing.

For ungrounded autotransformers with a tertiary, zero-sequence passes through the bank, and the current flowing in the tertiary reverses for faults on the two sides. Thus, the tertiary is not suitable for polarizing.

For the more common grounded autotransformers with tertiary, an example was given in [Chapter 4](#) (see [Section 4.12](#)). Expanding this in general terms will provide the criterion for use of these autotransformers for ground relay polarizing. The transformer and zero-sequencing networks are shown in [Figure 12.17](#). For a phase-to-ground fault on the high (H) side (see [Figure 12.17b](#)), the currents shown are the per-unit zero-sequence values. With I_{0H} in amperes in kV_H , the currents through the autotransformers are

$$\begin{aligned} \text{H winding: } & kI_{0H} \text{ A at } kV_H, \\ \text{M winding: } & pI_{0H} \frac{kV_H}{kV_M} \text{ A at } kV_M, \\ \text{L winding: } & (1-p)I_{0H} \frac{kV_H}{\sqrt{3}kV_L} \text{ A at } kV_L. \end{aligned}$$

This is the current inside the delta tertiary winding. The amperes follow Kirchhoff's laws, so the current up the neutral is

$$\begin{aligned} I_N &= 3 \left(kI_{0H} - pI_{0H} \frac{kV_H}{kV_M} \right) \\ &= 3I_{0H} \left(k - p \frac{kV_H}{kV_M} \right) \text{ A.} \end{aligned} \quad (12.7)$$

While examining Equation 12.7, we see that the distribution factors k and p are less than 1, normally k is greater than p , and the voltage ratio kV_H/kV_M is greater than 1. Thus, $p kV_H/kV_M$ can be greater than k , equal to k , or less than k for a specific autotransformer and connected system. Usually, the product is larger than k , so that I_N is negative and the current flows down the neutral.

Consider now a phase-to-ground fault on the low-voltage (M) winding. This is shown in [Figure 12.17c](#). With I_{0L} in amperes at kV_M , the currents through the autotransformers are

$$\begin{aligned} \text{H winding: } & tI_{0L} \frac{kV_M}{kV_H} \text{ A at } kV_H, \\ \text{M winding: } & sI_{0L} \text{ A at } kV_M, \\ \text{L winding: } & (1-t)I_{0L} \frac{kV_M}{\sqrt{3}kV_L} \text{ A at } kV_L. \end{aligned}$$

This is the current inside the delta tertiary winding. However, by Kirchhoff's laws, the current up the neutral is

$$I'_N = 3 \left(sI_{0L} - tI_{0L} \frac{kV_M}{kV_H} \right) = 3I_{0L} \left(s - t \frac{kV_M}{kV_H} \right) \text{ A.} \quad (12.8)$$

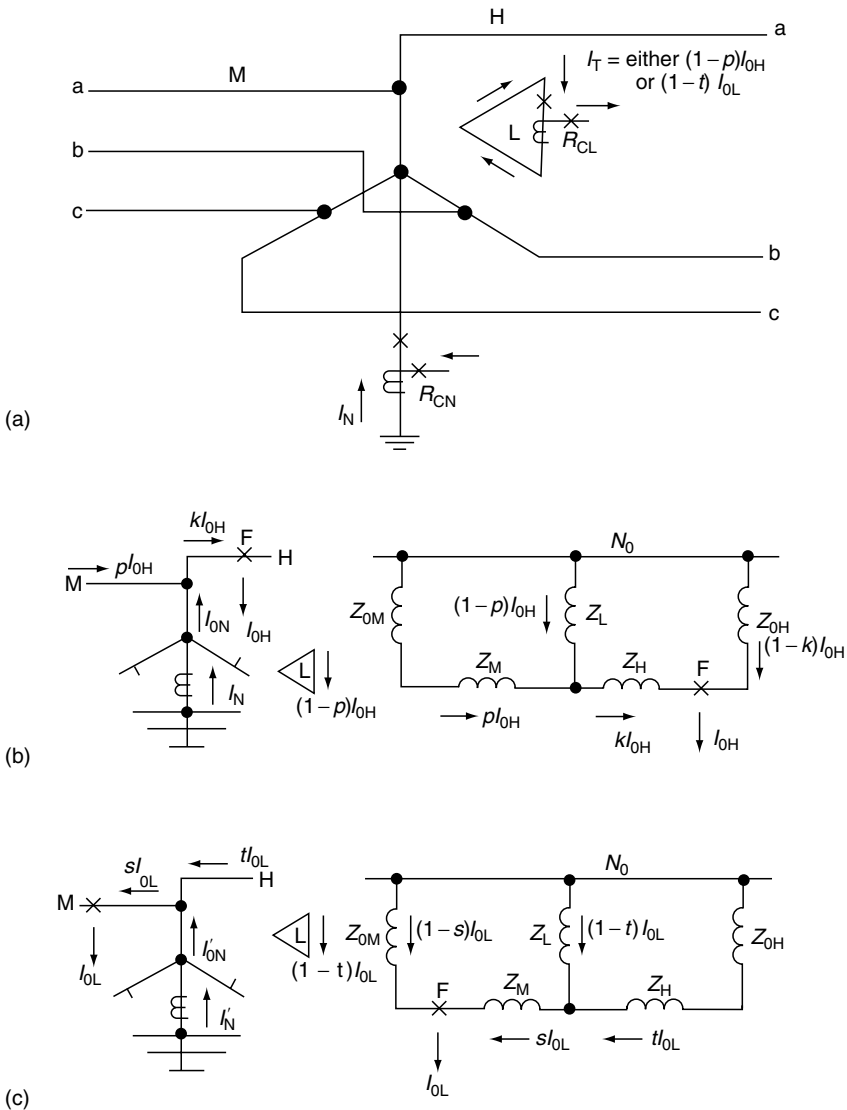

FIGURE 12.17 Ground relaying directional polarizing from an autotransformer bank with tertiary (grounded neutral CT seldom usable for polarizing): (a) three-phase diagram showing possible polarizing CTs; (b) zero-sequence network and current distribution for high-side (H) fault; (c) zero-sequence network and current distribution for medium (low) fault.

In this equation, the distribution factors s and t are less than 1; normally s is greater than t , and kV_M/kV_H is less than 1. As a result, the ratio $t(kV_M/kV_H)$ will always be less than s , so that I'_N is always positive and the current is up the neutral.

With the high probability of neutral current flowing down for high-side faults and up for low-side (M) faults, the neutral is not a reliable polarizing reference. In a given situation for which current does flow up the neutral for the high-side fault, care should be taken that this is correct for all possible variations of the low-voltage system impedance, Z_{0M} . Switching or changes during operation could result in a neutral current reversal.

Usually, the autotertiary current is in the same direction for high- or low-voltage system faults; therefore, it can be used as a polarizing current. As shown in Figure 12.17, one CT measures the I_0 current circulating. If load is connected or a generator tied into this tertiary, a CT in each of the three windings is required, with the secondaries in parallel, to cancel out positive and negative sequence and supply only $3I_0$ for relaying.

However, as documented in Chapter 4, the tertiary I_0 current can reverse for faults on one side of the bank, thereby making the tertiary unsuitable for polarizing. The reversal results when a relatively small MVA autotransformer, with a negative branch in the equivalent circuit, is connected to a very solidly grounded system. In other words, in Figure 12.17b, if Z_M is negative and larger than Z_{0M} , the current $(l-p)I_{0H}$ will be negative—a tertiary current reversal. Similarly, in Figure 12.17c, if Z_H is negative and larger than Z_{0H} , current in the tertiary $(l-t)I_{0L}$ is negative, to reverse the tertiary current. The equivalent-circuit negative for either Z_M or Z_H is small on the transformer base, but can become large when transferred to the larger-system base, where either Z_{0M} or Z_{0H} of the interconnected system is small because of the multigrounds.

Zero-sequence voltage can be used for polarizing, but it can be quite small. At least it does not reverse. The system equivalents Z_{0M} and Z_{0H} are always positive, and the zero-sequence voltage at the bank terminals consists of the drops across these impedances. Perhaps, a large series capacitor might cause a problem in this area, but this has not been experienced.

12.21 VOLTAGE POLARIZATION LIMITATIONS

Current polarization is preferred when it is available and can be used. Voltage polarization with $3V_0$ can be used at terminals with or without a grounding bank. At stations with large, solidly grounded transformer banks, the $3V_0$ levels should be checked for the remote faults to ensure adequate magnitude. This concern with zero-sequence voltage is illustrated in Figure 12.18.

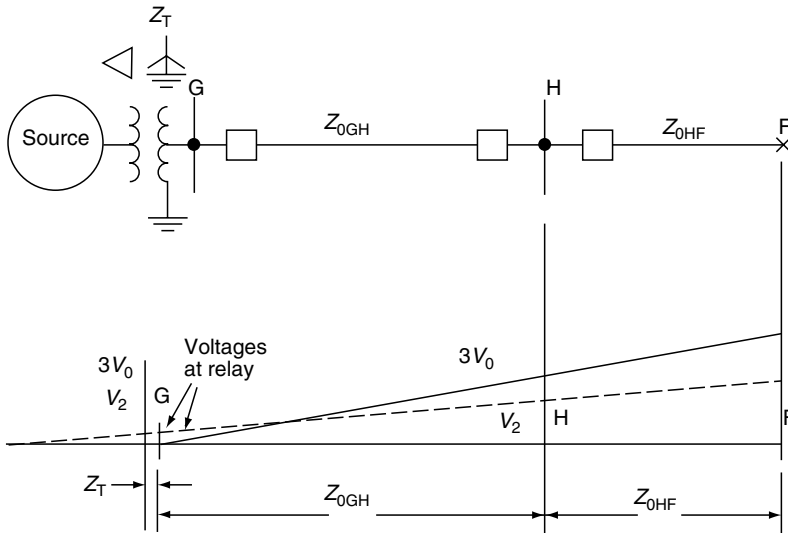

FIGURE 12.18 Typical voltage profiles of V_2 and $3V_0$ for ground faults.

With $3V_0$ maximum at the fault, the value at a grounding bank may be quite small. Z_T of the transformer is small because of the large bank, and Z_0 of the lines is large because of distance and the $\pm 3Z_1$ factor. Modern ground relay directional units are quite sensitive, so this may not pose a problem, unless long lines or settings are made well into the remote adjacent lines.

12.22 DUAL POLARIZATION FOR GROUND RELAYING

A common practice is to use current and voltage polarization jointly. Many ground relays are “dual polarized.” Some use two separate directional units, one voltage polarized and the other current polarized. They operate in parallel, so that either one can release the overcurrent units. Other designs use a hybrid circuit, with one directional unit that can be energized by current or voltage, or both. These types offer flexibility of application to various parts of the system.

12.23 GROUND DIRECTIONAL SENSING WITH NEGATIVE SEQUENCE

An excellent alternative is the use of negative sequence to operate the directional unit. Zero-sequence $3I_0$ is still used for the fault-detecting overcurrent elements, with V_2 and I_2 for the directional unit. It is applicable generally, but is particularly useful at autotransformer stations, with problems, as discussed earlier, and where mutual induction is involved, as discussed in [Section 12.24](#).

It is also applicable at stations where only open-delta VTs exit or where VTs are available only on the opposite side of wye–delta power transformers. In these circumstances, neither current nor voltage polarization is available.

Negative-sequence units are easy to field check for correct connections and operation—a problem with the relays connected in neutral circuits. Interchanging two phases to the negative-sequence current, or voltage filter, or inputs produces positive operation on balanced voltages or load currents.

The V_2 , I_2 quantities for ground faults are generally lower than the $3V_0$, $3I_0$ values and should be checked, and V_2 can be smaller or larger than $3V_0$, as indicated in Figure 12.18. General experience indicates that, in most instances, the V_2 and I_2 values are sufficient to operate available sensitive relays. Computer fault studies should be programed to include these negative-sequence values, and this method of polarizing has considerable merit in present-day power systems.

12.24 MUTUAL COUPLING AND GROUND RELAYING

Zero-sequence coupling between lines that are parallel for part or all of their length can induce false information in the unfaulted circuit and cause protection problems in both. The mutual impedance Z_{0M} can be as high as 50%–70% of the self-impedance Z_0 . To review this effect, Figure 12.19 shows the general case of parallel circuits. The voltage drops are

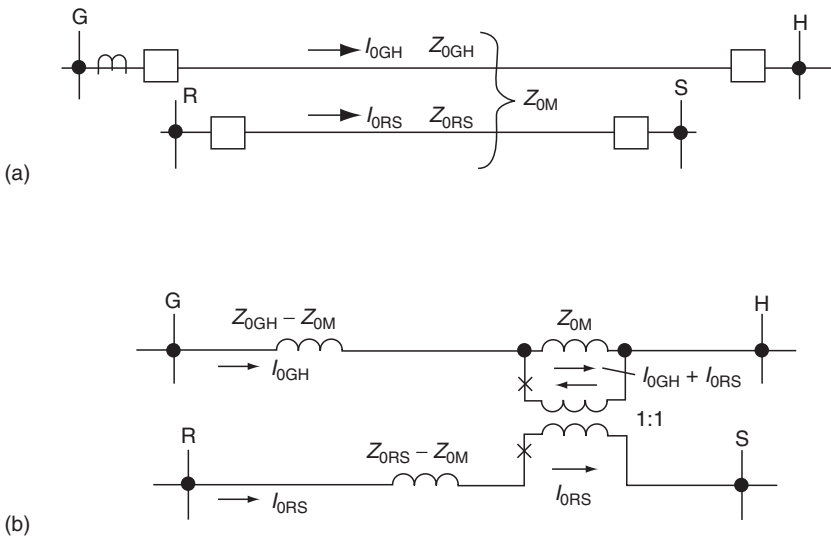

FIGURE 12.19 General example of paralleled lines with mutual coupling: (a) mutual-coupled lines; (b) equivalent network for (a).

$$V_{GH} = Z_{0GH}I_{0GH} + Z_{0M}I_{0RS}, \quad (12.9)$$

$$V_{RS} = Z_{0RS}I_{0RS} + Z_{0M}I_{0GH}. \quad (12.10)$$

For network analysis, these equations for the equivalent network shown in [Figure 12.19b](#) can be used. The ideal or perfect transformer with a 1:1 ratio is used, so that the mutual Z_{0M} is in both circuits, but isolated from direct electrical connection. The drops across this equivalent are the same as those of Equation 12.9 and Equation 12.10.

If three or more lines are paralleled, there will be a Z_{0M} value between each pair. That value times the respective current in the coupled line is added to Equation 12.9 and Equation 12.10. Additional ideal transformers with the respective Z_{0M} values would be added to the equivalent network shown in [Figure 12.19](#).

Lines GH and RS can be at the same or different voltages. With Z_{0M} determined in ohms from Carson's formula, as modified for zero sequence, the per-unit value from [Equation 2.15](#) is

$$Z_{0M} = \frac{\text{MVA}_{\text{base}} \times Z_{0M}(\text{ohms})}{\text{kV}_G \text{kV}_R} \text{pu}, \quad (12.11)$$

when line GH operates at kV_G and line RS at kV_R . If both lines are at the same voltage, the bottom term is kV^2 , as in Equation 2.15.

Quite often, the paralleled lines are bused at either one or both terminals. These circuits and their equivalent networks are shown in [Figure 12.20](#) and [Figure 12.21](#).

Where the two bused and coupled lines (see [Figure 12.21a](#)) have the same impedance Z_{0GH} , the equivalent impedance between bus G and H from [Figure 12.21b](#) will be

$$\begin{aligned} Z_{\text{eqGH}} &= Z_{0M} + \frac{1}{2}(Z_{0GH} - Z_{0M}) \\ &= \frac{1}{2}(Z_{0GH} + Z_{0M}). \end{aligned} \quad (12.12)$$

If $Z_{0M} = 0.7Z_{0GH}$, then, $Z_{\text{eqGH}} = 0.85Z_{0GH}$.

Thus, with currents flowing in the same direction, the mutual increases the impedance between the two buses, which would be $0.50Z_{0GH}$, without the mutual.

The foregoing discussion has emphasized mutual coupling by zero-sequence only. There is a coupling by the positive- and negative-sequence currents, but this induction effect is usually less than 5%–7% and, hence, has negligible effect on protection. As a result, negative-sequence directional units can usually be applied for correct directional sensing.

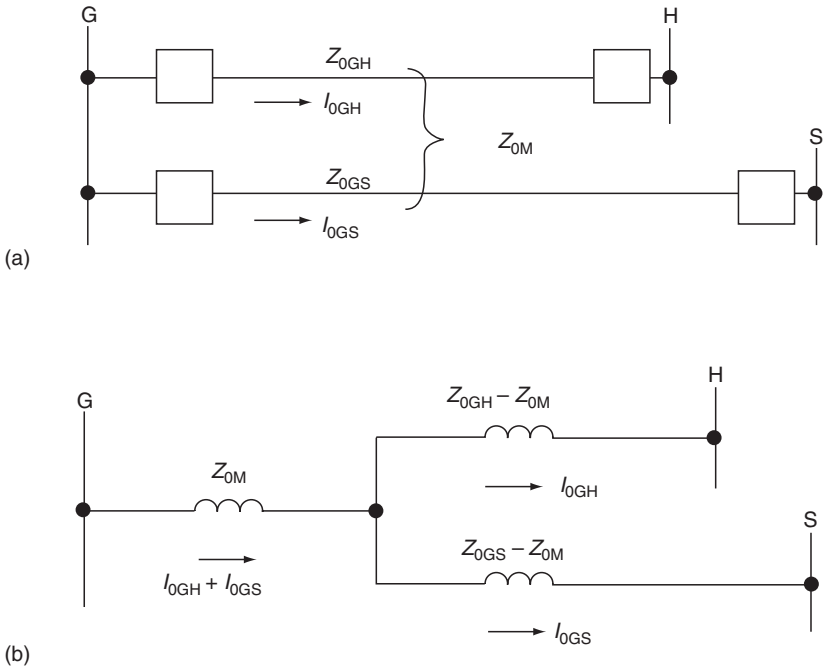

FIGURE 12.20 Parallel lines based at one terminal: (a) mutual-coupled lines; (b) equivalent network for (a).

In the systems shown in [Figure 12.22](#), the zero-sequence network for the line GH system is isolated electrically from that for the line RS system. The electromagnetic coupling acts as a transformer, such that current in one line tends to circulate current in the coupled line. A ground fault at or near one end will cause currents to flow as shown. In the faulted line GH, current up the two neutrals and out into the line is in the operating direction for the directional ground relays at both G and H. They should operate to open up the breakers at G and H. Before that happens, current I_{0RS} is induced in line RS. The directional unit at S will operate as the current is up the neutral and out into the line. The directional unit at R also operates, as current in and down the neutral is equivalent to up and out the line. The magnitude can be large enough to operate the overcurrent units, with the result that either breaker at R or S, or both, may be tripped incorrectly. The magnitude of the current in line RS is

$$I_{0RS} = \frac{Z_{0M}I_{0GH}}{Z_{TR} + Z_{0RS} + Z_{TS}}. \quad (12.13)$$

If G and R buses or H and S buses are in close proximity, so that the grounded-neutral CT in the two banks can be paralleled, correct polarizing

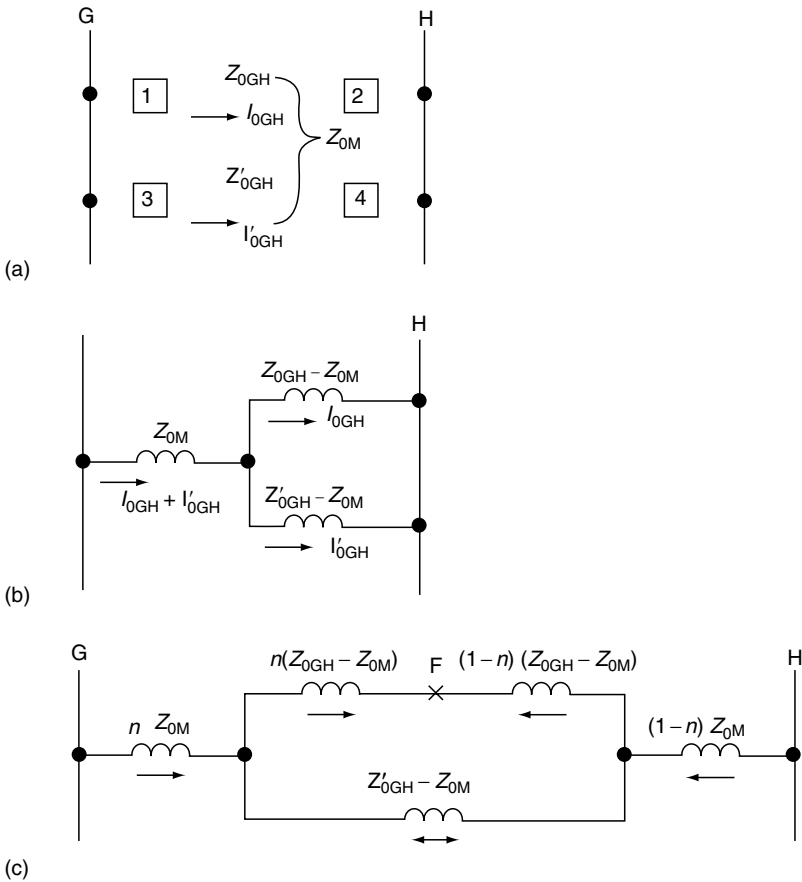

FIGURE 12.21 Paralleled lines based at both terminals: (a) the mutual-coupled lines; (b) the equivalent network for faults at the terminals; (c) the equivalent network for faults or taps in one-line sections.

can be obtained. The faulted line current up the neutral will be greater than the induced current down the neutral.

The $3V_0$ voltage for Figure 12.22 also will not provide correct polarizing. Correct directional sensing can be obtained by the use of negative sequence, but the induced $3I_0$ may be sufficient to operate the overcurrent units. For Figure 12.22, this would possibly cause the S terminal ground relays to misoperate.

Circuit switching in a zero-sequence electrically interconnected system can result in zero-sequence isolation and induced circulating currents. An example is shown in Figure 12.23. Lines GH and RH are mutually coupled and are connected together at bus H. For the ground fault close to breaker 2,

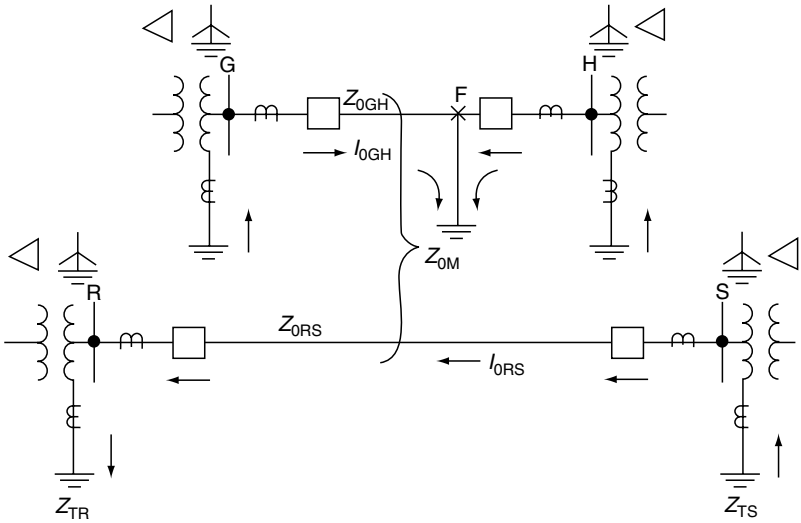

FIGURE 12.22 Fault current flow in lines with mutual coupling.

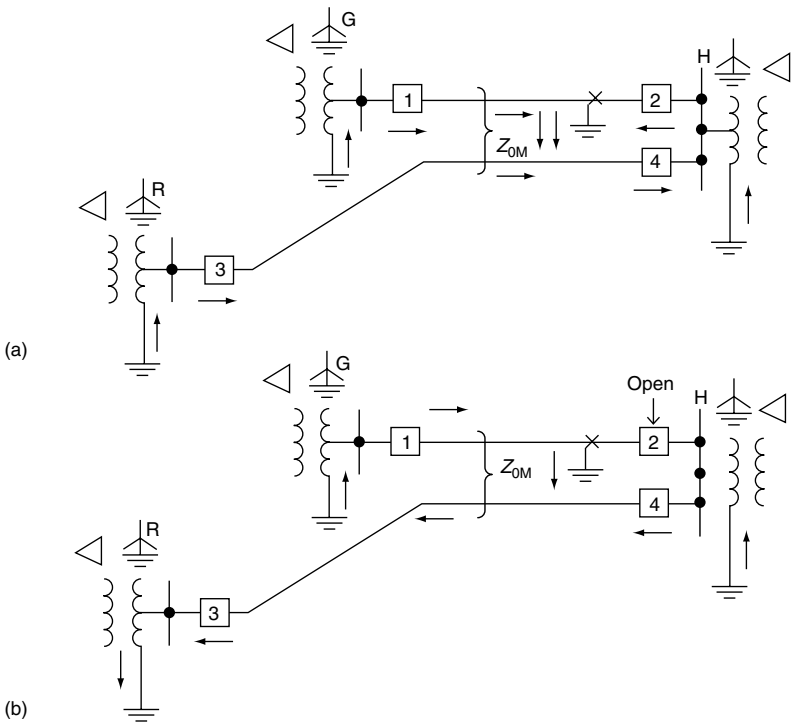

FIGURE 12.23 Zero-sequence electrical circuit isolation by switching, causing mutual to reverse current: (a) initial fault near breaker 2; (b) breaker 2 trips by instantaneous relays.

the zero-sequence current flows are shown in [Figure 12.23a](#). This is defined by the equivalent circuit of [Figure 12.20](#). If the fault is in the zone of the instantaneous units at 2, they will operate fast to open breaker 2. This now isolates the two circuits electrically, as shown in [Figure 12.23b](#), and, until breaker 1 opens, an induced current circulating in the line RH system reverses the line current and causes current to flow down instead of up in the transformer-neutral at station R. Zero-sequence directional units, either current polarized or voltage polarized, would operate at both ends to indicate an internal fault on line RH. Thus, incorrect tripping of either breaker 3 or 4, or both, can occur. This is a “race” with a possibility that breaker 1 will open to clear the fault before relay 3 or 4 can operate. This situation has explained intermittent incorrect tripping in several systems, which was solved by applying negative-sequence directional sensing.

Multiple mutual coupling can cause current reversals in systems that are not zero-sequence electrically isolated. An example is shown in [Figure 12.24](#). The two lines G to H are coupled with the line R to S. Station H is a very large and solidly grounded station. Therefore, very high ground-fault currents flow from H to the fault near station G. With the system interconnected, as shown, the normal zero-sequence current flow to the fault should be up the neutral at station S, and over the line from S to R to join the current at R and continue through line RG to the fault. However, the very large currents coupled to line RS can result in the reversal of line RS current from its normal anticipated direction. This reversal is shown in the figure. Again, zero-sequence current or voltage directional units would operate at both R and

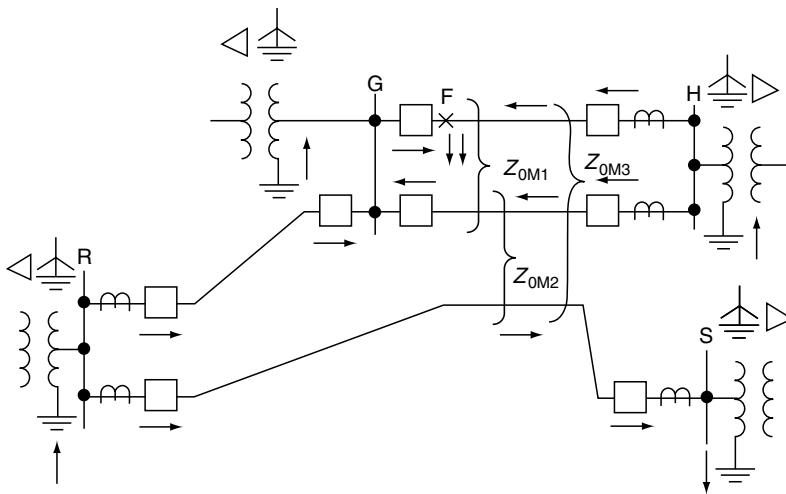

FIGURE 12.24 Current reversal by mutual without zero-sequence electrical circuit isolation.

S, to suggest a fault on line RS with possible incorrect tripping before the faulted line relays can operate and the breakers clear the fault.

There is a very high probability of this condition occurring more frequently, as environmental and economic concerns force the use of existing rights-of-way for more lines. As a result, mutual coupling is an increasing problem. Hence, it is very important that all mutuals be included in the fault program and carefully considered in protection.

As has been suggested, negative-sequence directional sensing can often provide correct indications, but it does not solve all problems. In Figure 12.24, negative-sequence current would flow from S to R, so negative-sequence directional unit at S senses a fault in line RS, and with overcurrent sufficient to operate the zero-sequence fault detectors, relay S tends to operate. At R, the negative-sequence directional unit blocks this relay operation.

An incorrect operation with negative-sequence ground directional relays occurred to open breakers 3 and 5 for a ground fault out on line from breaker 1 (Figure 12.25). These several lines were coupled as shown. The ground fault induced sufficient current to circulate in the secondary loop to operate the overcurrent zero-sequence units. Negative sequence from the industrial plant flows through both paralleled lines, so both directional units at the industrial plant substation closed. The result was incorrect tripping of both breakers 3 and 5 and, unfortunately, dumping of an important load. This particular problem was corrected by raising the overcurrent settings at breakers 2, 3, 4, and 5 above the induced current. As the exposure to line 1 was short, the higher setting still provided good protection for faults on lines 2–3 and 4–5.

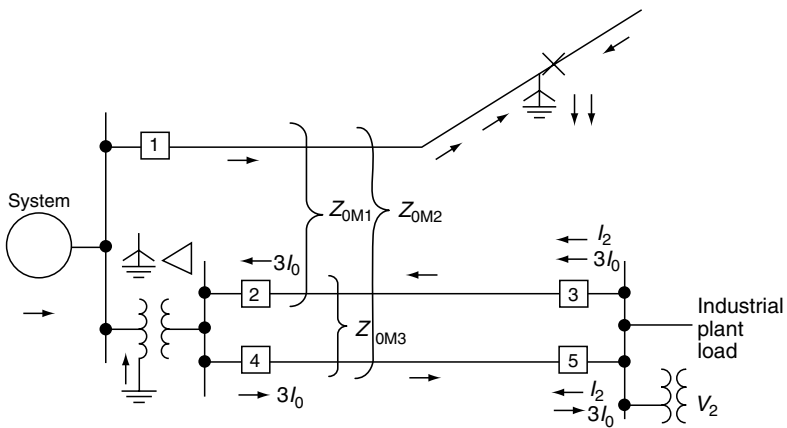

FIGURE 12.25 Example of misoperation with mutual coupling and negative-sequence directional sensing.

12.25 GROUND DISTANCE RELAYING WITH MUTUAL INDUCTION

The mutual coupling will produce either a higher apparent impedance and relay underreach or a lower apparent impedance and relay overreach. Current flowing in the paralleled line in the same direction as the fault current in the protected line will cause a higher apparent impedance (see Equation 12.9) and underreach. Current flowing in the opposite direction produces a lower apparent impedance and overreach.

Consider ground distance relays at breaker 3 (see Figure 12.21a) with zone 1 set for 85% of the line 3–4 impedance, without any mutual compensation. Zone 1 will reach approximately 70%, with current in line 1–2 flowing from 1 to 2 as shown. If breaker 4 opens first, the current in line 1–2 reverses to cause zone 1 at 3 to reach out and cover approximately 100% of the opened line.

Zone 2 should be set for approximately 150% of the line section, to ensure that it will cover all of the line for primary protection, with current in the parallel line flowing in the same direction. With this setting, zone 2 of breaker 3 should coordinate correctly with breaker 2, zone 2.

As a general rule, mutual compensation is not recommended for ground distance relays. If it is used, care must be taken to ensure proper operation when the paralleled line current changes direction from that for which the compensation was set.

12.26 LONG EHV SERIES-COMPENSATED LINE PROTECTION

Series capacitor banks are frequently inserted in long power lines to reduce their total impedance, thereby permitting the transmission of more power with less loss and for higher system stability limits. Protection for the capacitors themselves are discussed in Chapter 9. The capacitors may be inserted in the line at any point, but for economic reasons, they are often installed in the line at the terminal stations, as illustrated in Figure 12.26. In this example, directional mho distance relays can operate undesirably, as shown in Figure 12.26b. The distance relays at 1 set to protect line GH cannot see faults in capacitor X_{CG} and part of the line, as this impedance area falls outside the circular operating characteristics. However, the distance relays at 3 for the protection of the line-to-line GH. As a result, distance relays are not recommended for these lines, unless one is willing to assume that the capacitor protective gaps will always short out the capacitor for faults in this problem area. This is a reasonable gamble, for the gaps are fast and reasonably

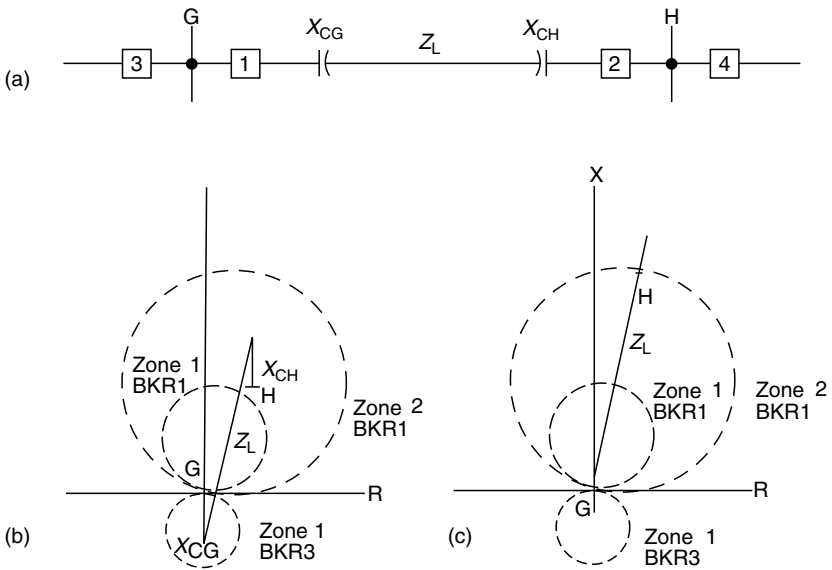

FIGURE 12.26 Protection problems encountered with series-compensated transmission lines: (a) a typical series-compensated line with series capacitor banks at the station terminals; (b) R - X and distance relay diagrams with capacitor banks in service; (c) R - X and distance relay diagrams with capacitor banks out of service.

reliable. Zone 1 solid-state relays may require a short-time delay; electro-mechanical relays probably will not.

When the gaps flash, the line becomes as shown in Figure 12.26c. To cover the long line without the capacitors, a long reach or large ohm setting is required for zone 2 (and zone 3 if used). This setting may be a problem with load or recovery stability limits, so that one of the restricted distance characteristics of Figure 6.12 will be required. In addition, with the capacitors in service, zone 2 or zone 3 reach may cause coordination problems with relays at breaker 4 at station H.

Phase comparison pilot systems are preferred for these systems. Current-only systems will not have the problems of correctly sensing internal and external faults. Distance fault detectors do not have to be directional, so can be applied and set to operate for all faults in the line with or without the capacitor banks in service.

The segregated phase comparison system is especially applicable to these types of lines. This is outlined in Chapter 13.

12.27 BACKUP: REMOTE, LOCAL, AND BREAKER FAILURE

Remote versus local backup was introduced in Section 6.4. In this section, backup protection has been included throughout the protection chapters in two basic forms: redundancy and remote. Redundancy is the additional protection provided in the primary protection zone, and sometimes extending into the adjacent system. Example are three separate phase relays, instead of two or a single unit, to serve all three phases: phase relays backing up ground relays, timed-overcurrent and distance-timed zones backing up the instantaneous or pilot relays, and in EHV and UHV, two separate pilot systems. The degree of independence of the various protection schemes is a measure of the redundancy available. A very high redundancy is obtained for the EHV and UHV systems by operating the two pilot systems from separate CTs and VTs or CCVTs, separate trip coils in the circuit breaker, and separate station batteries. If separate batteries are not available, separate fused supplies from the single battery are used. A similar arrangement is sometimes used for the voltage supply. This provides the maximum redundancy that is economically practical.

Remote backup is the overlapping of the primary relays in one protection area into the adjacent areas. Thus, in Figure 12.27a, relays 1 at station S, relays 5 at station T, and relays 8 at station R should provide backup to the relays and breaker 3 at station G for faults on line GH. That is, if breaker 3

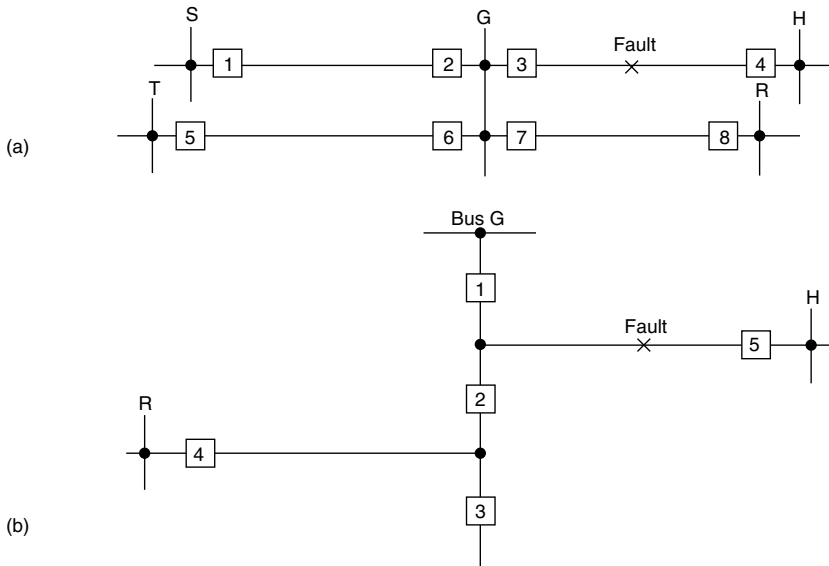

FIGURE 12.27 Power system configurations to illustrate backup protection: (a) backup on a single bus system; (b) backup on a ring or breaker-and-half bus system.

does not open for these faults, the remote breakers 1, 5, and 8 must open to clear line GH faults.

As has been indicated, this becomes quite difficult or impossible, especially for faults near station H, because of the infeed effect from the currents or the other lines. This tends to reduce the current or increase the impedance seen by the remote relays. If the remote relays can see line GH faults, the operating time may be relatively slow because of coordination requirements necessitated by the other lines out of service. Sometimes, these difficulties can be solved by sequential remote tripping. If one remote terminal can operate on backup, its removal may result in a redistribution of fault current sufficient to operate the other remote backup relays.

With the advent of EHV and UHV systems in the recent past, two problems have developed. One was that, initially, the higher-voltage circuit breakers were subject to a higher failure incidence than previously encountered. The other was that system stability required much faster backup. Thus, breaker failure–local backup systems were applied.

Instead of opening breakers 1, 5, and 8 in [Figure 12.27a](#) for a failure of either relays or breaker 3 to open on line GH faults, local backup would open the local breakers 2, 6, and 7. This can be done with minimum delay; ideal times as low as 150–250 msec are in use.

Breaker failure is initiated when the primary protection operated, but the breaker does not open. Local backup is identical, except that a second and independent primary relay system should be provided to cover the failure of the relays to operate. As indicated, very high redundancy in relay systems is used for higher-voltage systems.

When local backup is applied to lower-voltage systems, careful attention should be given to adequate relay redundancy to cover all possible relay failures. Remote backup by its separate location provides 100% redundancy for the faults within their operating range.

Remote backup is still important as an additional and “last resort” protection, and is necessary with ring or breaker-and-a-half buses. This is illustrated in [Figure 12.27b](#). For faults on line GH, breakers 1 and 2 at bus G are tripped. If breaker 1 fails to open, local backup would trip the necessary breakers off bus G (not shown). If breaker 2 fails to open, local backup would trip breaker 3, but the fault is still supplied through breaker 4 at station R. Thus, breaker 4 must be opened. This can be accomplished by remote backup operation of the relays at 4. With the infeed through breakers 1 and 3 removed, the possibility of relays 4 seeing faults on line GH is increased. Transfer trip of breaker 4 by the local backup at G is another possibility. This requires information that breaker 2 is in trouble and not breaker 1 or 3.

Typical local backup-breaker failure schemes are shown in [Figure 12.28](#). The trip circuits of the two redundant (independent) relay systems are of pilot type, and its operating times can be equal to or faster than the primary system. With a single trip coil on the breaker, the primary directly trips the breaker by

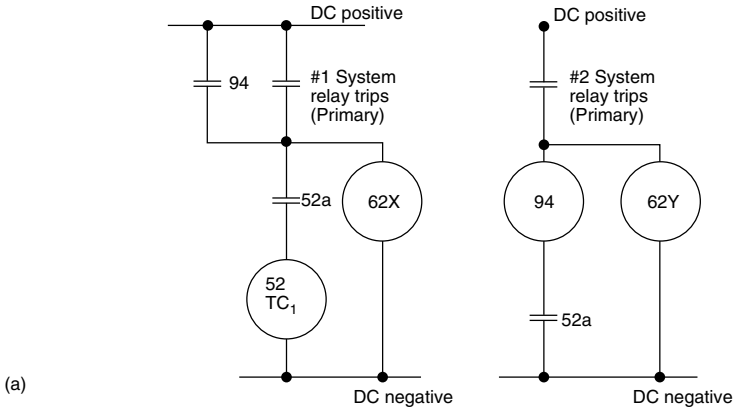

(a)

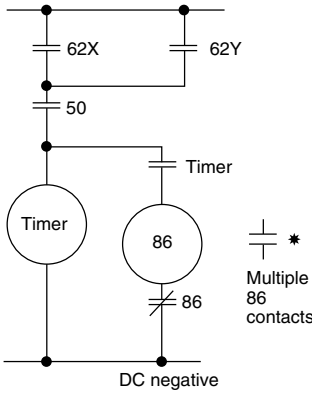

(b)

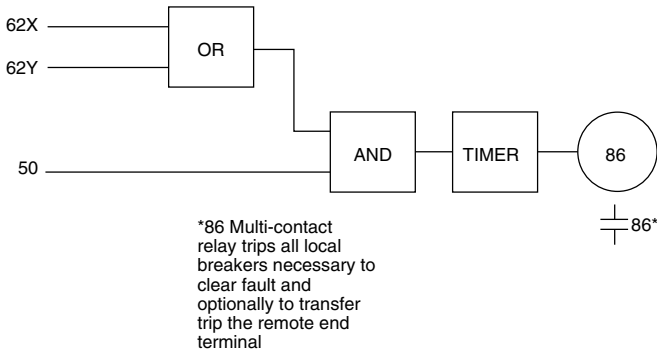

(c)

FIGURE 12.28 Typical breaker failure–local backup DC (schematic): (a) typical circuit breaker trip systems and auxiliaries for breaker failure–local backup (where breakers have double trip coils, 94 relay coil, and contact is omitted and the second trip coil 52 TC₂ connected in place of the 94 relay coil); (b) typical contact logic for breaker failure–local backup; (c) typical solid-state logic for breaker failure–local backup.

energizing the trip coil 52TC₁, and the secondary energized relay 94 which, in turn, operates 52TC₁. With double trip coils, 94 is omitted, and the secondary system directly energizes the second trip coil 52TC₂.

At the same time, auxiliary relays 62X and 62Y are energized. Either relay operates a timer supervised by a 50 relay. This is a low-pickup non-directional instantaneous overcurrent relay with a high dropout ratio. It is generally connected in two phases and ground. The phase units should be able to carry the maximum load at their low settings. This 50 relay monitors the current through the breaker and provides a final check on breaker current flow, with fast opening to stop the timer, should the breaker open late. The operation of the timer energizes a multicontact auxiliary (86) relay, which is the only one that is manually resettable. The 86 relay contacts initiate tripping of all the breakers locally required to clear the fault, and may also initiate a transfer trip signal to the remote terminal(s) to ensure that the relays have operated correctly for the internal fault. There are several variations of the schemes and connections for the various bus configurations. Microprocessor-based breaker failure relays are available that include programable logic that allows the user to select that which best suits user needs and philosophy.

1. Up to 34.5–69 kV: directional time–overcurrent for phase or ground with nondirectional or directional instantaneous overcurrent where applicable.
2. 34.5–115 kV: directional distance (two or three zones) for phase, same as item 1 for ground, alternate-ground distance.
3. 69–230 kV: pilot relaying (see Chapter 13) for phase and ground as primary protection, backup as item 2.
4. 230 kV and above: two pilot systems (primary and secondary) (see Chapter 13) for phase and ground, additional backup as item 2.
5. For very short lines at any voltage level: pilot wire or pilot type (see Chapter 13) for phase and ground, backup as per 1 or 2, but coordination with other protection may not be completely possible.
6. Multiterminal and tapped lines: pilot-type relays generally required, unless load-type impedance or transformer connections will permit proper discrimination for external faults.

12.28 SUMMARY: TYPICAL PROTECTION FOR LINES

The typical protection recommended and generally applied for the protection of lines is outlined in Figure 12.29 for radial lines and feeders, and in Figure 12.30 for loop lines. Once again, there are many variables, circumstances, operating conditions, and local practices that can modify these general suggestions and practices. The pilot systems indicated are discussed in Chapter 13.

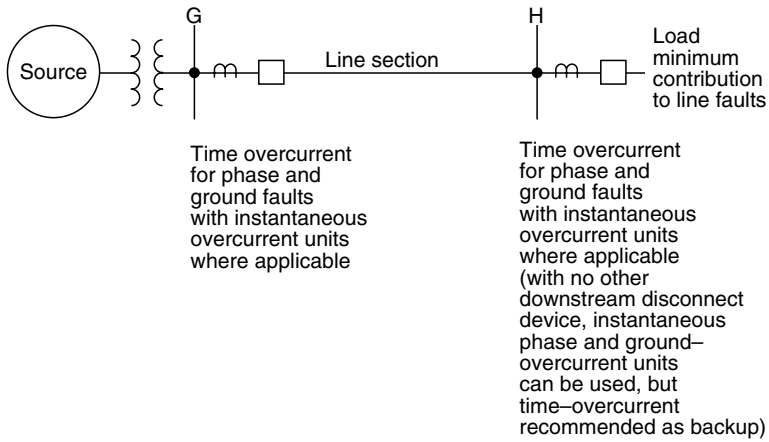

FIGURE 12.29 General summary and suggested protection for radial lines and feeder circuits. Fuses or reclosers may be used either downstream or upstream, in which case the time and instantaneous overcurrent relays must be selected and set to coordinate with these other devices. Complete coordination may not always be possible under all possible operating conditions. When minimum fault current is less than the maximum possible load current, apply a distance-controlled overcurrent relay.

12.29 PRACTICAL CONSIDERATIONS OF LINE PROTECTION

Over the years, performance of line protection has received the highest degree of attention and scrutiny. This is because most power system faults occur on lines, and, as such, the associated protection is frequently challenged. The considerable distance that typically exists between line terminals and the need for communication channels also cause challenges for protection performance. In addition, considering the high cost and difficulties encountered in building new lines, power systems are operated with line loadings approaching very close to their design limits. Incorrect operation of line relays during faults or undesired operating on load or recoverable transients has initiated or contributed to the scope of many major electrical disturbances that have occurred in the country. One needs only to scan through the NERC reports

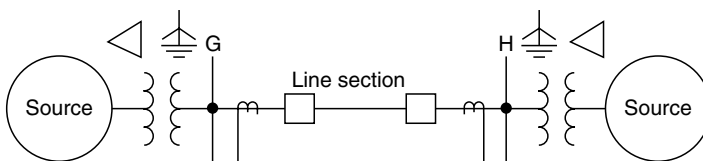

FIGURE 12.30 General summary and suggested protection for loop lines and circuits. Protection at both terminals.

that summarize major electrical disturbances to understand the significant role that the performance of line relaying has played during the sequence of events of many of these incidents. The protection engineer is constantly challenged to seek strategies to improve performance of line protection. New technologies, such as the use of fiber optics for communication channels along with advances in digital systems, have gone a long way in providing the protection engineer better tools for meeting this challenge. It is highly important that the use of new technologies and techniques be considered and analyzed in designs for line protection schemes on a continual basis, so that performance remains on an upward trend. Innovative thinking is also required on the part of the protection engineer responsible for the application of protection on power systems, to look beyond the obvious and expected operating states of the power system, and to consider the impact of less probable and more severe conditions when specifying and anticipating performance of protection.

BIBLIOGRAPHY

- ANSI/IEEE Standard C37.95, Guide for Protective Relaying of Consumer–Utility Interconnections, IEEE Service Center.
- ANSI/IEEE Standard C37.103, Guide for Differential and Polarizing Relay Circuit Testing, IEEE Service Center.
- ANSI/IEEE Standard C37.108, Guide for the Protection of Network Transformers, IEEE Service Center.
- Blackburn, J.L., Voltage induction in paralleled transmission circuits, *AIEE Trans.*, 81, 1962, pp. 921–929.
- Bozoki, B., J.C. Benney, and W.V. Usas, Protective relaying for tapped high voltage transmission lines *IEEE Trans. Power Appar. Syst.*, PAS 104, 1985, pp. 865–872.
- Burke, J.J. and D.J. Lawrence, Characteristics of fault currents on distribution systems, *IEEE Trans. Power Appar. Syst.*, PAS 103, 1984, pp. 1–6.
- Curd, E. and L.E. Curtis, *Procedure for an Overcurrent Protective Device Time–Current Coordination Study*, Vol. 1, No. 1 Section 110, Square D Power Systems Engineering Data, Square D. Co., Middletown, OH, 1979.
- Distribution System Protection Manual*, Bulletin No. 71022, McGraw-Edison Co., Canonsburg, PA.
- Dugan, R.C. and D.T. Rizy, Electric distribution protection problems associated the interconnection of mall dispersed generation systems, *IEEE Trans. Power Appar. Syst.*, PAS 103, 1984, pp. 1121–1127.
- de Mello, F.P., J.W. Feltes, L.N. Hannett, and J.C. White, Application of induction generators in power systems, *IEEE Trans. Power Appar. Syst.*, PAS 101, 1982, pp. 3385–3393.
- Elmore, W.A. and J.L. Blackburn, Negative sequence directional ground relaying, *AIEE Trans.*, 81, 1962, pp. 913–921.
- Griffin, C.H., Principles of ground relaying for high voltage and extra high voltage transmission lines, *IEEE Trans. Power Appar. Syst.*, PAS 102, 1983, pp. 420–432.

- IEEE-PES, Protection Aspects of Multi-terminal Lines, IEEE-PES Special Publication 79TH0056-2-PWR, IEEE Service Center.
- IEEE Tutorial Course, Application and Coordination of Reclosers, Sectionalizers and Fuses, 80EHO157-8-PWR, IEEE Service Center.
- Lewis, W.A. and L.S. Tippett, Fundamental basis for distance relaying on a three-phase system, *AIEE Trans.*, 66, 1947, pp. 694–708.
- Power System Relaying Committee, Local backup relaying protection, *IEEE Trans. Power Appar. Syst.*, PAS 89, 1970, pp. 1061–1068.
- Power System Relaying Committee, EHV protection problems, *IEEE Trans. Power Appar. Syst.*, PAS 100, 1981, pp. 2399–2406.
- Power System Relaying Committee, Distribution line protection practices, industry survey analysis, *IEEE Trans. Power Appar. Syst.*, PAS 102, 1983, pp. 3279–287.
- Rook, M.J., L.E. Goff, G.J. Potochnry, and L.J. Powell, Application of protective relays on a large industrial–utility tie with industrial co-generation, *IEEE Trans. Power Appar. Syst.*, PAS 100, 1981, pp. 2804–2812.
- Wang, G.N., W.M. Moffatt, L.J. Vegh, and F.J. Veicht, High-resistance grounding and selective ground fault protection for a major industrial facility, *IEEE Trans. Ind. Appl.*, IA20, July–Aug. 1984, pp. 978–985.

13 Pilot Protection

13.1 INTRODUCTION

Pilot protection used for lines provides the possibilities of high-speed simultaneous detection of phase- and ground-fault protection for 100% of the protected section from all terminals: the ideal primary protection goal. It is a type of differential protection for which the quantities at the terminals are compared by a communication channel, rather than by a direct-wire interconnection of the relay input devices. The latter is impractical because of the distances between the several terminals. Similar to differential schemes, pilot schemes provide primary zone protection and no backup. Thus, they do not require coordination with the protection in the adjacent system unless additional backup is included as a part of the pilot scheme.

This protection is applicable at all voltages. In actual practice, it is usually applied to short lines at all voltages and to most lines at about 69–115 kV and higher. The application key is the importance of the circuit in the power system and the necessity for rapid clearing of faults for stability and service continuity.

This chapter outlines the fundamentals and basic operation of the several systems in common use in the United States. Currently, many of the pilot systems that are installed are digital in nature. Most modern digital based pilot relays incorporate much of the pilot scheme logic that previously required the use of slower and more cumbersome auxiliary relays with electromechanical contacts. In addition, the use of digital communication systems has improved the overall performance of pilot relay schemes.

13.2 PILOT SYSTEM CLASSIFICATIONS

The pilot protection systems can be classified into two categories:

1. By channel use:
 - a. Channel not required for trip operations; known as blocking systems
 - b. Channel required for trip operations; known as transfer trip systems
2. By fault detector (FD) principle: the comparison at the several terminals of:
 - a. Power flow, known as directional comparison
 - b. The relative phase position of the currents, known as phase comparison

- c. Wave deflection from a fault: a relative new ultrahigh-speed system with application primarily to EHV transmission lines.

A particular scheme is usually described or identified by a combination of these two categories. The major schemes in use can be identified more specifically:

- A. Directional comparison systems
 - 1. Directional comparison blocking
 - 2. Directional comparison unblocking
 - 3. Overreaching transfer trip
 - 4. Underreaching transfer trip
 - a. Nonpermissive
 - b. Permissive
- B. Current-based systems
 - 1. Current differential
 - a. AC pilot wire
 - b. Digital current differential
 - 2. Charge comparison
 - 3. Phase comparison
 - a. Single-phase comparison: blocking
 - b. Dual-phase comparison: unblocking
 - c. Dual-phase comparison: transfer trip
 - d. Segregated phase comparison
- C. Directional wave comparison

13.3 PROTECTION CHANNEL CLASSIFICATIONS

The channels used for protective relaying are as follows:

1. *Pilot wires*: A twisted wire pair for transmitting 60, 50 Hz DC between terminals. Originally telephone pairs were used, privately owned dedicated pairs are preferred.
2. *Audio frequency tones*: On–off or frequency-shift types over wire pairs, power-line carrier, or microwave.
3. *Power-line carrier*: Radio frequencies between 30 and 300 kHz, transmitted chiefly over high-voltage transmission lines. On–off or frequency-shift types are used.
4. *Microwave*: Radio signal between 2 and 12 GHz, transmitted by line-of-sight between terminals. Multiple channels with protection by a subcarrier or audio tone.
5. *Digital Channel*: Types of media include dedicated optical fiber (dark fiber) or multiplexed networks. Multiplexed networks include T1 multiplexing, SONET, digital microwave, and radio links. When

owned by the utility, fiber-optic cables can be imbedded in the ground wire, wrapped around a power cable, or buried along the right-of-way. Digital channels may also be leased from an outside telecommunications company.

These are discussed in more detail in [Section 13.14](#).

13.4 DIRECTIONAL COMPARISON BLOCKING PILOT SYSTEMS

This is the oldest type of system, which was first used in the 1930s. It is still very widely used and is the most versatile and flexible system, especially applicable for multiterminal lines. The direction of the power flow at the terminals is compared. For internal faults, the power (current) flows into the line at the terminals, so simultaneous high-speed tripping at the terminals is permitted. For external faults, the information that current flows out at one of the terminals is used to block tripping of all terminals.

This system is usually applied with an “on-off” power-line carrier channel (see [Section 13.14.1](#) and [Figure 13.7](#)). The transmitter-receivers at the two terminals are tuned to a common RF frequency. Separate frequencies, as well as other types of channels can be used. A basic schematic of this system is shown in [Figure 13.1](#). In general, distance relays for phase faults and directional instantaneous overcurrent relays for ground faults are used as FDs. The channel signal is initiated by distance phase and instantaneous overcurrent units known as carrier start (S) relays. The FDs must be directional and set to overreach all remote terminals under all operating conditions. Because this is also the requirement for zone 2 distance relays, these are used in the pilot system. The pilot trip for internal faults is in parallel with the time-delay T_2 trip.

The carrier (channel) start units must be set more sensitively or to reach farther out on the line than the remote FD. In other words, in [Figure 13.1a](#), S_1 units at breaker 1, bus G must operate for all phases or ground faults to the left of 1 that can operate FD_2 at breaker 2, bus H. Similarly, S_2 must operate for all phases and ground faults at bus H and to the right that can operate FD_1 at G. Normally, a zone 3 distance relay is used, but connected to see out of the protected line section instead of into the line, as discussed in [Chapter 12](#). The conventional mho characteristic that passes through the origin cannot respond adequately to provide blocking for the possibility of a solid zero-volt fault just external to the relay. Accordingly, the zone 3 distance relay has a small current-only torque or bias to provide positive operation for these faults.

Both electromechanical and electronic systems are in service, and their basic operation is the same. A typical operating logic diagram is shown in [Figure 13.1b](#). For the logic boxes, “1” is used to indicate a logic input or

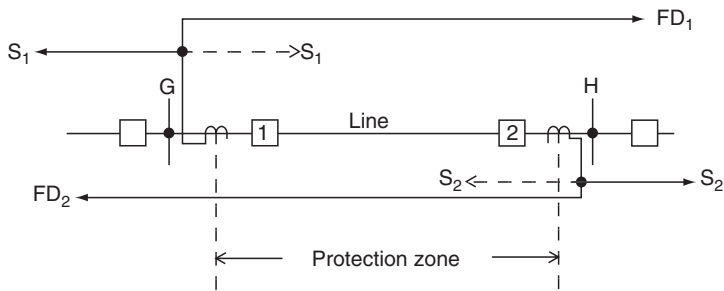

(a) Power system and relay setting diagram

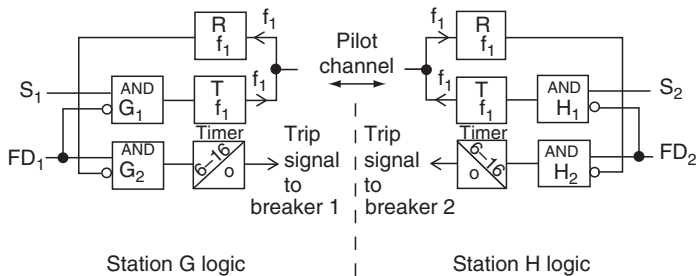

(b) Solid state logic diagrams

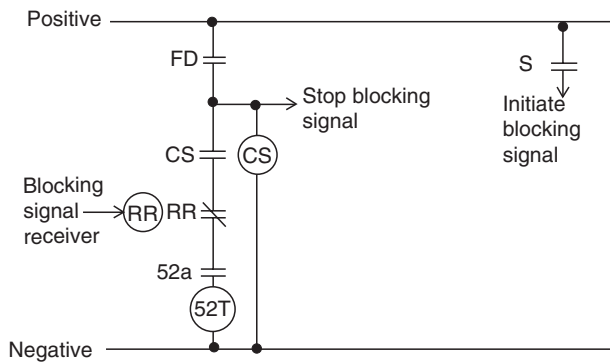

(c) Contact logic diagram

FIGURE 13.1 Basic operating principles of the directional comparison blocking pilot system.

output signal, and “0” for no or an insufficient input or output signal. The “AND” logic box requires all inputs to be 1 to have 1 as output. The small circle (o) at the box indicates that 1 appears to the box as 0 and vice versa. The top numbers in the timer logic box represent the time in milliseconds for an output to occur after an input (pickup time). The lower number is the reset (dropout) time.

The operation for an external fault, for example, on bus H or on the line(s) to the right of the bus, is as follows:

Relays 2 at bus H: FD₂ does not operate, S₂ does operate. AND H₁ thereby has both inputs 1 to key the carrier transmitter on. The RF signal f₁ is received locally and transmitted to station G. AND H₂ has two 0 inputs; neither will provide an output. Thus, breaker 2 is not tripped.

Relays 1 at bus G: The RF signal f₁ received provides a 0 on AND G₂ thus there is no output to trip breaker 1 although FD₁ operates. FD₁ operation provides a 0 on AND G₁, so the transmitter is not keyed, although S₁ may operate on this external fault.

Thus, the carrier (channel) signal at H is used to block the overreaching trip relays at G from operating on this external fault. Correspondingly, an external fault on or to the left of bus G will provide a blocking signal from G to H to block the overreaching H relays from tripping.

For internal faults in the protected zone:

Relays 1 at bus G: FD₁ operates for 1 as an input to AND G₂ and 0 as an input on AND G₁. Thus, the station G transmitter will not be turned on or will be stopped should S₁ operate before FD₁. No signal is transmitted to H.

Relays 2 at bus H: FD₂ operates for 1 as an input to AND H₂ and 0 as an input to AND H₁. Thus, the station H transmitter will not be turned on or will be stopped should S₂ operate before FD₂. No signal is transmitted to G.

With no channel signal from either terminal, both AND G₂ at G and AND H₂ at H energize their respective timers and both breakers are tripped at high speed. The typical 6 to 16 msec delay is for coordination between the various operating relays. The channel is not required for tripping; therefore, should an internal fault interrupt the channel signal, tripping can still occur.

The basic contact logic for electromechanical relays is shown in [Figure 13.1c](#) and is equivalent to the operation just described. For internal faults, directional overreaching phase or ground relays (FD) operate to stop their local blocking signal (carrier stop). If no blocking signal is received from the remote terminals, relay (RR) remains close and the tripping is initiated. CS provides about 16 msec coordinating time.

For an external fault at any terminal, S phase or ground (carrier start) units initiate a blocking signal to energize RR at the remote terminals. This opens the trip circuit at that terminal to block a trip should any FD relays have operated. At the external fault terminal, FD will not have operated, so both FD and RR are open.

13.5 DIRECTIONAL COMPARISON UNBLOCKING PILOT SYSTEM

This system is developed around frequency-shift (FSK) channels, such as an FSK power-line carrier. This equipment provides excellent narrowband transmission at low power with receivers that are highly insensitive to noise. An RF signal is transmitted continuously in one of two modes, known as *block* or *unblock*. Typical shifts for these are ± 100 Hz from a center RF frequency. One watt is used for the block mode, and either 1 or 10 W for the unblock mode.

With a continuous signal transmitted, it can be used to block relay operation and, thereby, eliminate the channel start relays (S) that are required in the preceding system. For internal faults, the relay-blocking signal is shifted to unblock, to permit the relays to trip instantaneously. Because a signal must be transmitted, the unblock signal can be used to augment tripping. In addition, this type of channel can be monitored continuously, which is not possible with on-off channels.

A typical unblock system is shown in Figure 13.2. As illustrated in Figure 13.2a, only FDs are required. They are of the same types and settings as described in Section 13.4. Both the phase and ground relays must always overreach all remote terminals for all operating conditions to provide 100% internal line-fault protection.

As documented by the logic diagrams of Figure 13.2b and Figure 13.2c, the operation is as described in the following. This is a typical system; other arrangements are possible.

13.5.1 NORMAL-OPERATING CONDITION (NO FAULTS)

Both frequency-shift transmitters at station G (FSK T_G) and station H (FSK T_H) are transmitting in the block mode, so that from their respective receivers (FSK R_G) and (FSK R_H) the block signal is 1 and the unblock signal is 0. Thus, the outputs of OR G_1 and OR G_2 at station G and of OR H_1 and OR H_2 at station H are all 0. FD₁ at G and FD₂ at H are not operated, so the AND G_3 and AND H_3 inputs are all 0 and no trip is indicated.

As shown, separate frequency channels are required between the stations indicated by f_1 and f_2 . The ideal spacings between these are about 1 kHz for narrowband equipment. Transmission of these frequencies is continuous during their operation.

13.5.2 CHANNEL FAILURE

If one channel is lost for any reason, so that there is no block signal output, the protection is blocked out of service and an alarm is set off. In Figure 13.2b, if the block signal from FSK R_G is lost (goes to 0) without a shift to unblock

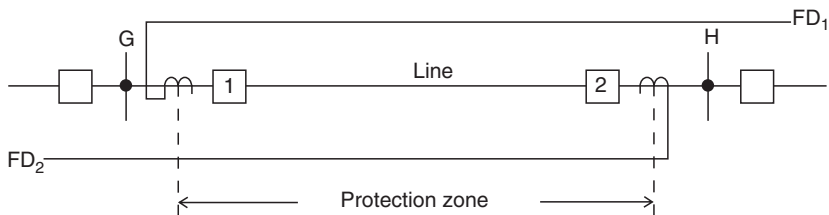

(a) Power system and relay setting diagram

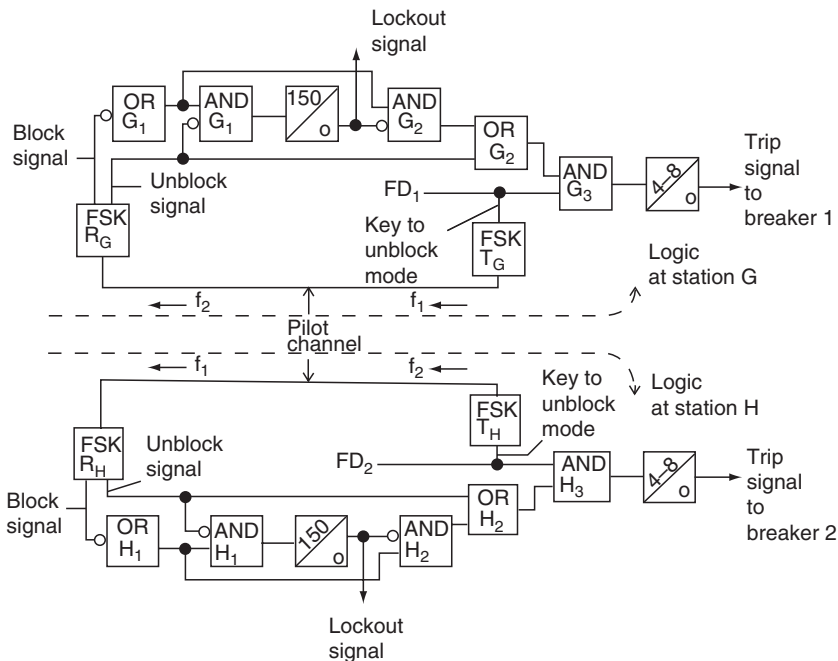

(b) Solid-state logic diagrams

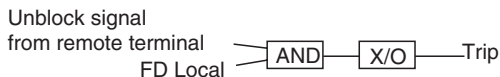

(c) Simplified logic diagram

FIGURE 13.2 Basic operating principles of the directional comparison unblocking pilot system using a frequency-shift channel.

mode, so that it remains at 0 at station G, OR G₁ has 1 as both input and output. At this point AND G₁ has input 1 to energize the timer. After 150 msec, the relay system is locked out with an alarm.

13.5.3 EXTERNAL FAULT ON BUS G OR IN THE SYSTEM TO THE LEFT

Relays 1 at station G: FD₁ relays do not operate. This directly prevents tripping of breaker 1 and permits the FSK T_G transmitter to continue in the blocking mode.

Relays 2 at station H: Block signal 1 continues, so OR H₁ has no input; hence, no output. Thus, the lower input to AND H₃ is 0, so it can have no output even though FD₂ has operated with 1 on AND H₃. Thus, tripping is blocked by the blocking signal from station G. The operation of FD₂ keys the transmitter FSK T_H to unblock.

Back at station G: Reception of the unblock signal from station H by FSK R_G operates OR G₂, but AND G₃ cannot operate because FD₁ has not operated.

13.5.4 INTERNAL FAULTS IN THE PROTECTED ZONE

At station G: FD₁ operates to key FSK T_G to unblock and to input 1 to AND G₃.

At station H: FD₂ operates to key FSK T_H to unblock and to input 1 to AND H₃.

At both stations: The operation is the same. Considering station G, the unblock signal 1 with the FD₁ signal 1 operates AND G₃ to initiate breaker 1 tripping after about a 4 to 8 msec delay for operating coordination. This unblock signal is not necessary for tripping. Removal of the block signal operates OR G₁ and, in turn, AND G₁ if the unblock signal is delayed or not received because of the fault. The bypass from OR G₁ to AND G₂ causes it to operate with 0 unblock signal on AND G₁. This AND G₂ output lasts until the timer operates, which is sufficient to permit a trip signal through OR G₂ and AND G₃.

Therefore, this system operates as a “blocking type,” where no channel signal is required for the timer interval (150 msec as shown), then becomes a “transfer trip” type. This provides a combination of the advantages of both the types, as reviewed in a later section. It is applicable to power-line carrier channels, which should not be used for the transfer trip systems.

13.6 DIRECTIONAL COMPARISON OVERREACHING TRANSFER TRIP PILOT SYSTEMS

Power-line carrier channels are not used or recommended for these systems. A signal must be received from the remote terminal(s) to trip, and with power-line carrier, the signal could be interrupted or shorted out by a fault. Therefore, these systems are used normally with audio tones over telephone circuits or modulated on microwave channels. “Trip-guard” tones are used. The guard

is monitored. The arrangement is similar to that described in the foregoing. Loss of channel (guard) for about 150 msec locks out the protective relays from tripping and setting of the alarms. After the guard signal returns, the relays are restored to operation after about 150 msec.

A typical system is shown in Figure 13.3. The same types and settings of directional phase distance and ground directional instantaneous overcurrent

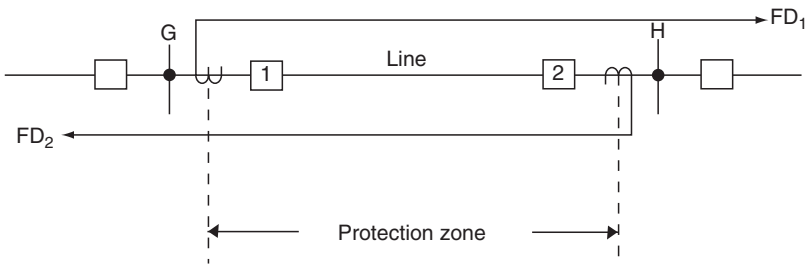

(a) Power system and relay setting diagram

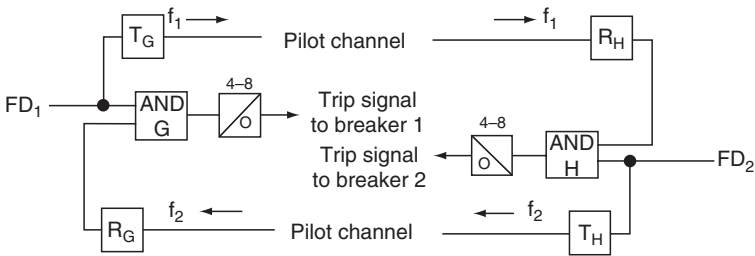

(b) Solid-state logic diagrams

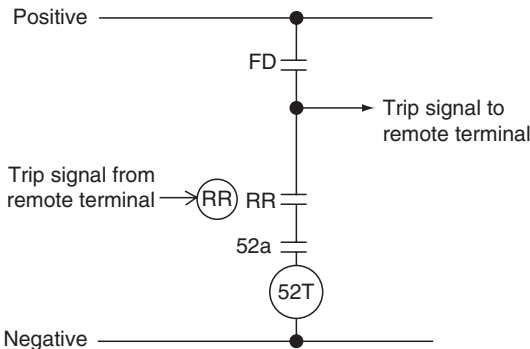

(c) Contact logic diagram

FIGURE 13.3 Basic operating principles of the directional comparison overreaching transfer trip pilot system.

relays are used, as for the previous systems. However, it is important that these should be set to overreach the remote terminal(s) under all operating conditions. If we consider [Figure 13.3b](#):

13.6.1 EXTERNAL FAULT ON BUS G OR IN THE SYSTEM TO THE LEFT

Relays 1 at station G: FD_1 relays do not operate. Tripping cannot take place. Transmitter T_G continues to operate in the guard mode.

Relays 2 at station H: FD_2 relays operate, but cannot trip, for receiver R_H does not input to AND H in the guard mode. FD_2 does shift transmitter T_H to the trip mode, so at station G this receiver energizes the AND G, but as before, FD_1 does not.

Thus, both terminals are blocked from tripping on the external faults.

13.6.2 INTERNAL FAULTS IN THE PROTECTED ZONE

The operation is the same at both terminals. FD_1 and FD_2 both operate to shift their respective transmitters to the trip mode. This is received at the remote receivers and provides an input into the AND G and AND H, which, with the FD_1 and FD_2 inputs, provide a trip output, and both breakers are operated simultaneously at high speed. The 4 and 8 msec delay provides coordination time between the various components.

The operation with electromechanical relays is the same as for solid state and is shown in [Figure 13.3c](#). Directional phase or ground relays (FD) operate for faults on the line or beyond and send a trip signal to the remote terminal to close RR. If the fault is internal the FD at both terminals operate, send trip signals, and thus, both ends trip. If the fault is external, the FD that does not operate does not permit tripping and does not send a trip signal; therefore, the other terminal cannot trip.

13.7 DIRECTIONAL COMPARISON UNDERREACHING TRANSFER TRIP PILOT SYSTEMS

These systems require that the FDs be set such that they always overlap, but do not overreach any remote terminal under all operating conditions. Phase directional distance zone 1 units meet this requirement and so are used in this system. Instantaneous overcurrent relay “reaches” vary with current magnitude, and it becomes difficult, and sometimes impossible, to ensure that these relays for ground faults always overlap, but not overreach. Thus, distance ground relays are recommended for this system and set as in the foregoing for zone 1.

The channels required are the same as those for the overreaching transfer trip systems. Two types exist: (1) nonpermissive, shown in Figure 13.4b and (2) permissive (see Figure 13.4c). With the setting indicated, all external faults do not operate any of the FDs. On the internal faults FD₁ at bus G and FD₂ at bus H both trip directly for faults in the area of the overlap. Both of these detectors key their respective channel transmitters to the trip mode. This provides a trip output at the receivers to directly trip the terminal breakers. No time delay is required.

This system is not in general use because of the very high security requirements of the channels. Any transient or spurious operation of the receiver will result in incorrect operation. Consequently, overreaching FDs, of the type and setting described in the foregoing, are added. These are used to supervise the channel. As seen in Figure 13.4c, a trip signal through the channel requires that the overreaching FDs operate so that AND G or AND H, or both, can have an output to trip the breakers.

The operation with electromechanical relays is illustrated in Figure 13.4d. Because the directional phase or ground relays (FD) do not overreach any remote terminal, they can trip directly at each terminal. The operation of FD also sends a tripping signal to the remote terminals to close RR and directly energize the trip in the nonpermissive system. With the addition of optional overreaching phase and ground relays, as shown, the tripping by the remote terminal is supervised. This is the permissive directional comparison underreaching system.

13.7.1 ZONE ACCELERATION

A variation of the underreaching transfer trip system is referred to as “zone acceleration.” As in the underreaching scheme, zone acceleration uses underreaching distance elements to initiate tripping directly and to key the transfer trip channel. Receipt of the transfer trip signal at a terminal does not initiate a trip directly but acts to extend the reach of the underreaching units at the receiving location such that they become overreaching units. End-zone faults near one of the line terminals are cleared at the terminal remote from the fault by action of the switched overreaching distance relay at that location rather than directly by the transfer trip signal. This logic lowers the security concern of the underreaching scheme as previously described because a fault detecting relay must operate at a terminal in order for a trip to be initiated. With zone acceleration logic, the total time to clear an end-zone fault will be more or less longer than that of the underreaching scheme as additional time is required for switching the setting and then for the operation of the overreaching distance element. This scheme certainly requires the use of distance elements with setting switching capability. Such capability is available in most modern digital distance relays.

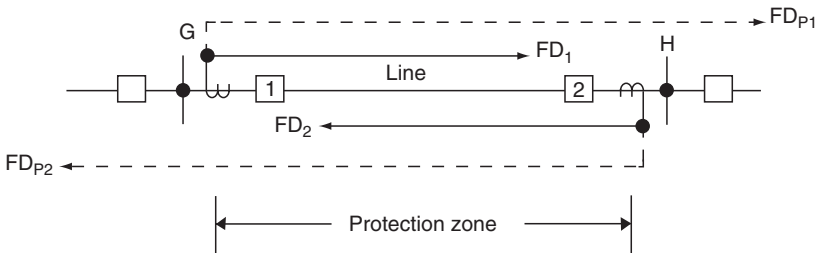

(a) Power system and relay setting diagram

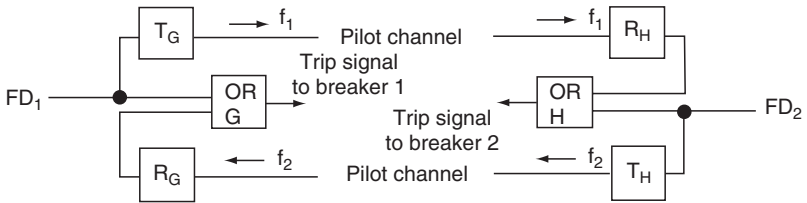

(b) Solid-state logic diagrams—Nonpermissive underreaching transfer trip

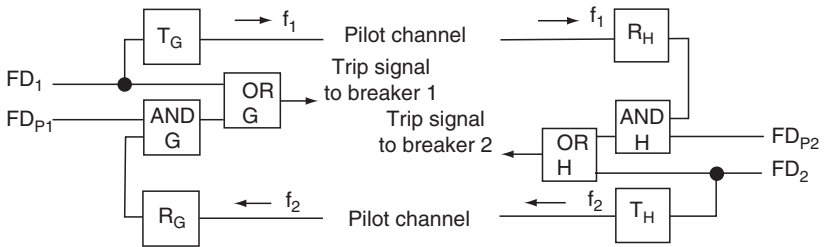

(c) Solid-state logic diagrams—Permissive underreaching transfer trip

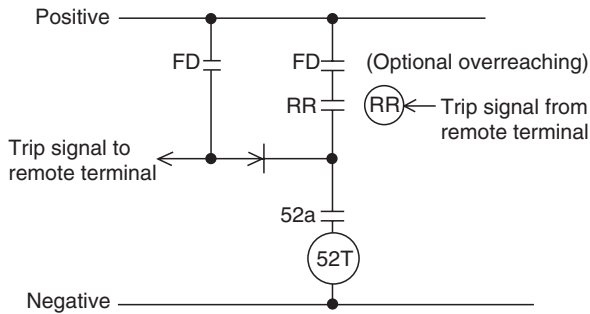

(d) Contact logic diagram—Nonpermissive. Permissive with optional FD.

FIGURE 13.4 Basic operating principles of the directional comparison underreaching transfer trip pilot system.

13.8 PHASE COMPARISON: PILOT WIRE RELAYING– WIRE-LINE CHANNELS

This widely used system for short lines is developed between 1936 and 1938. Dr. E.L. Harder conceived that a single-phase voltage

$$V_F = k_1 I_1 + k_0 I_0 \quad (13.1)$$

was representative of all types of power system faults and could be used for protection and could be compared with telephone circuits. The author's first assignment in relaying was to perform many fault calculations on typical systems to assure that this single-phase voltage V_F was viable. Several other combinations have been used to provide a single-phase voltage from the three-phase currents.

The three-phase and neutral currents are connected to a sequence filter, which provides a single-phase voltage output V_F . One design is as Equation 13.1 or, subsequently, as Equation 13.2. Power system voltages are neither involved nor required

$$V_F = k_1 I_1 + k_2 I_2 + k_0 I_0, \quad (13.2)$$

where I_1 , I_2 , I_0 are the positive-, negative-, and zero-sequence current components, respectively, derived from the line currents I_a , I_b , I_c . In addition, k_1 , k_2 , k_0 are network factors adjustable by taps and the design of the sequence network. All types and levels of faults produce combinations of positive, negative, and zero sequence. Thus, all faults above the relay sensitivity can be detected. For ground faults, k_0 can be made large for high ground-fault sensitivity. With the filter output of Equation 13.1 and where $Z_1 = Z_2$, the phase-to-phase fault pickup is higher by $\sqrt{3}$ than the three-phase fault pickup (the phase-to-phase actual fault current is 0.866 less than three-phase current). For short lines, this lower sensitivity to the phase-to-phase faults was seldom a problem. With the network output of Equation 13.2, the phase-to-phase fault pickup is lower (higher fault sensitivity) than the three-phase pickup.

The output voltage from the sequence networks V_F or the voltage from other-type networks is compared with the similar output voltage from the remote terminals. The system using a "telephone"-type wire-line channel has been widely used over many years. The basic circuit is shown in [Figure 13.5](#). The sequence network voltage is passed through a saturating transformer. This limits the voltage to essentially a constant magnitude of about 15 V; hence, it is independent of the wide variations that occur in fault currents.

This voltage is connected to the pilot wires through a restraint coil R, with an operating coil OP across the pair and the insulating transformer. Typically, a 4:1 or 6:1 ratio transformer is used, providing a maximum pilot wire voltage

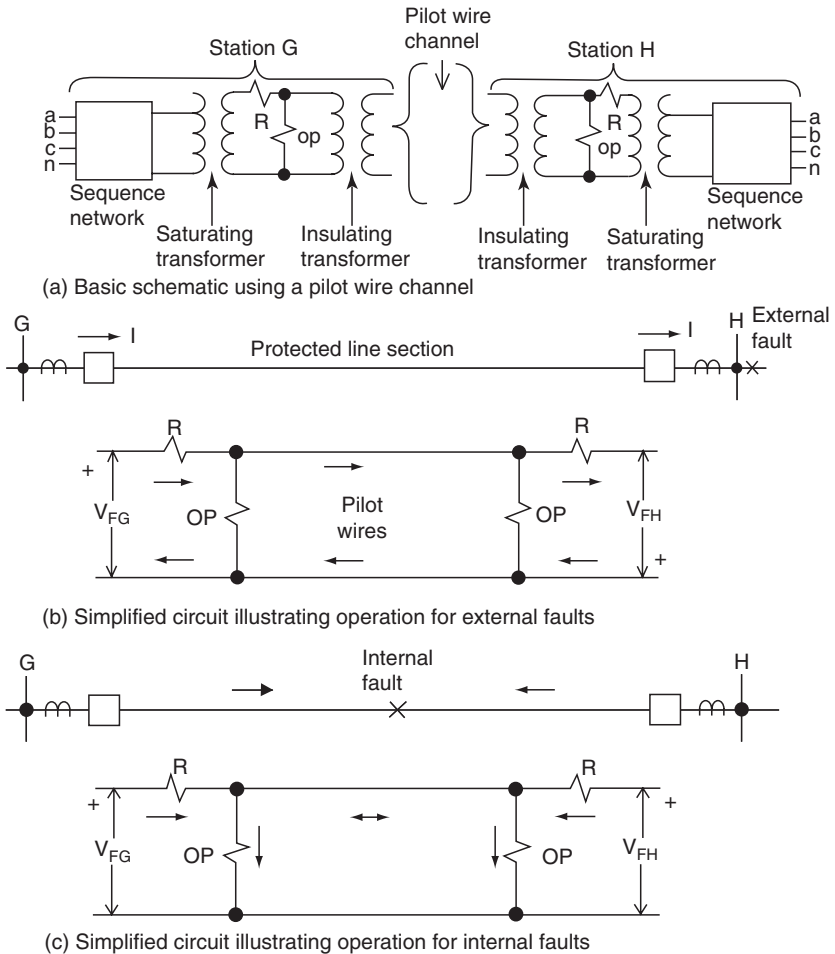

FIGURE 13.5 Typical pilot wire-relaying system for line protection. Principle also used with audio tones or fiber optics (see Section 13.8).

of about 6 or 90 V. The pilot wire side insulation of this transformer is about 10 to 15 kV to ground and between the windings.

Current in the operating R coil tends to prevent relay trip operation, whereas current in the operating OP coil produces relay operation. With equal current in R and OP and above the pickup value, this relay operates to energize the breaker trip coil.

The operation of the system for external faults is illustrated in Figure 13.5b. Through current, either load or to external faults, results in a circulating current through the pilot wire pair, as shown, with only a small portion

passing through the operating OP coil. The higher current through the restraint R coil prevents relay operation at both terminals.

For internal faults (Figure 13.5c), current flowing to the fault particularly circulates through the restraint R and operating OP coils in series with a small current over the pilot pair. If the contribution to the fault from stations G and H were equal, no pilot wire current would flow. The other extreme possibility is that, there is no contribution to the fault from bus H; then, the current through G would divide between the local operating coils and, through the pilot wires, the remote operating coil at H. If the fault current through G in this instance is high enough, both terminal relays can operate to provide simultaneous high-speed tripping of both ends. This is occasionally quite desirable.

Thus, over a wide range of current magnitude and distribution, this system provides high-speed simultaneous protection for both phase and ground faults. As can be seen, this is a differential-type protection, operating on the total-fault current, and a 50 to 60 Hz phase comparison type.

Three terminal applications are possible with this system. The added terminal relay is connected across the pilot pair with its pilot pair forming a wye-connection with the other two pilot wire branches. The pilot wire-wye connection should have legs of equal impedance. Because different distances will exist between the terminals, balancing resistors are used to provide this balance.

Supervision of the pilot pair for opens, shorts, or grounds is obtained by circulating about 1 milliamperes of DC current over the pair, with sensing relays at each terminal. These are connected at the midpoint of the insulating transformer on the pilot wire side. This winding is split at the midpoint and a small capacitor connected between the two halves to permit the 50 to 60 Hz signals to pass. The supervisory DC voltage is applied across this capacitor. At the other end(s), sensing relays are connected across similar capacitors at those terminals. Interruption or increase of the circulating current provides alarm indications. The equipment can also be used for a transfer trip channel in either or both directions. For this, the DC current in the supervisory equipment is reversed and increased to operate the transfer trip relays.

With this supervision equipment connected to the pilot wires, special attention must be given to probable high voltage from induction or station ground rise. For personnel safety, neutralizing and mutual drain-gauge reactors and gaps should be used in most applications.

13.9 PHASE COMPARISON: AUDIO TONE OR FIBER-OPTIC CHANNELS

The current-only system with a single-phase voltage to represent all types of phase and ground faults (see Section 13.8) was extended, about mid-1940s, for the protection of longer transmission lines. One typical system uses V_F of

Equation 13.2. This voltage is passed through a squaring amplifier that produces square waves for transmission and comparison at the remote terminal.

For security, two-level FDs may be used, both overreaching, such that they operate for all internal phase and ground faults. Normally, these are current-operated units. Where the minimum internal fault currents are on the order of or less than maximum load current, distance units are applied for the phase-fault detectors. This means that the system now requires VTs and is not a current-only system. In either event, the high-level detector is set about 125% to 250% of the low-level unit.

A typical system and its operation are illustrated in Figure 13.6. At breaker 1, station G, the fault detectors are FD_{1S} and ED_{1T} , and at breaker 2,

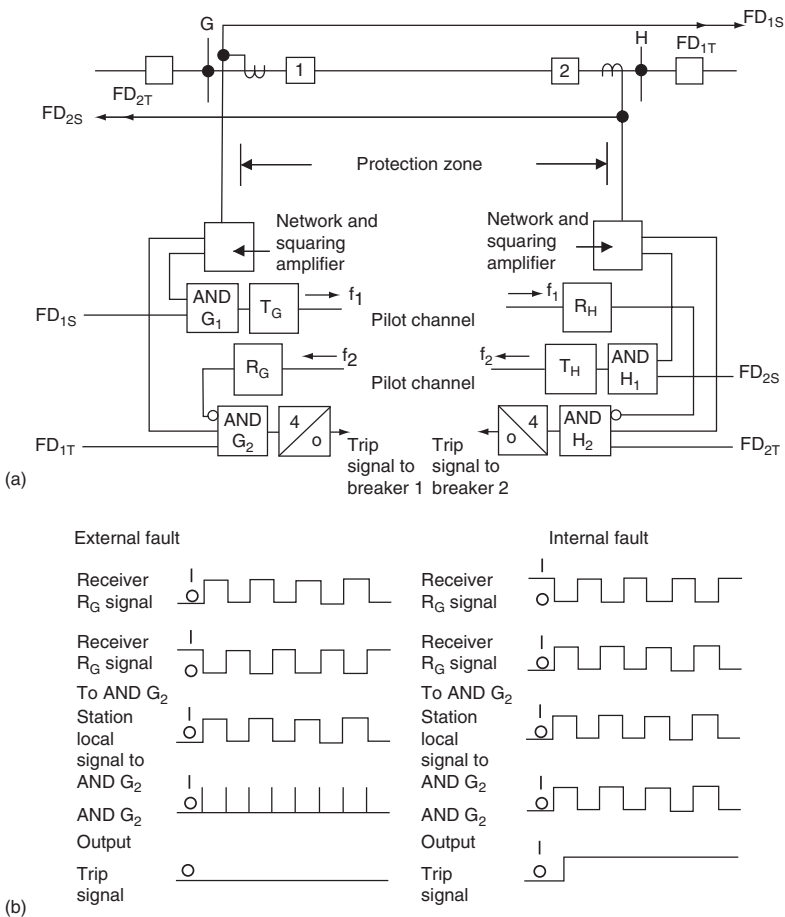

FIGURE 13.6 Basic operating principles of phase comparison pilot system; single half-wave comparisons over audio tone channels: (a) system logic diagrams; (b) typical system operation for relays at 1 bus G for external faults at bus H and to the right, and for internal faults.

station H, the fault detectors are FD_{2S} and FD_{2T} . The S units are set more sensitively (lower-current pickup or longer-distance reach) than the T units. As shown in the figure, the squaring amplifier produces square waves that are at the maximum on one half of the 50 to 60 Hz wave and zero on the other half of the wave.

With similar equipment and settings at the two terminals, the operation at bus G for relays 1 is as follows:

13.9.1 EXTERNAL FAULT ON BUS H OR IN THE SYSTEM TO THE RIGHT

FD_{1S} and FD_1 operate to input 1 to AND G_1 and AND G_2 , respectively. At station H, FD_{2S} and FD_{2T} (both nondirectional) operate to input 1 on AND H_1 and AND H_2 . Thus, FD_{2S} and the squaring amplifier output start transmission of square waves from transmitter T_H over pilot channel f_2 to receiver R_G . The polarities are such that this train is as shown, and is negated as input to AND G_2 . Thus, AND G_2 is energized only for a very short interval, if at all, for short spikes of output considerably less than the 4 msec required for operation. For the external faults assumed, the currents into the line at 1 should be in phase with the currents out of the line at 2 for all practical purposes (line losses and phase shifts are normally negligible except for very long lines). Time delay is provided for the local signal to compensate for the differences and the channel delays; accordingly, tripping does not occur for the external faults. The system at breaker 2, station H operates in a similar manner, and both terminals operate similarly for faults on bus G and in the system to the left.

13.9.2 INTERNAL FAULTS IN THE PROTECTED ZONE

All FDs at both terminals operate. At station H, the current of relay 2 has reversed for the internal faults, so the received signal and the input to AND G_2 are essentially in phase with the local square waves from relays at 1. These provide positive square output from AND G_2 and after 4 msec, a trip output.

The full half-wave output shown assumes that the currents at stations G and H are 180° out of phase or flowing into the line in phase. With load flowing across the line, this is not true, but these systems can trip with the currents at the two stations out of phase up to 90° . In 60 Hz systems, a phase angle difference of 90° corresponds to 4 msec. Similar operation for the internal faults occurs at relays 2, station H.

This system can be used with on-off power-line carrier channels. For the internal faults, if a receiver signal is not received, AND G_2 will have 1 as an input continuously. Trip operation can occur at both ends by the local signal input plus the local FD_T operation.

The systems presently described provide comparison on only one half cycle. If the fault should occur on the zero-output half cycle, tripping for internal faults is delayed until the next half cycle.

If FSK power-line carrier or “mark-space” audio tone channels are available, comparison can be made on either half cycle of the 50 to 60 Hz wave. This is known as *dual-phase comparison*. Equipment similar to that of [Figure 13.4](#) for comparing each half cycle is required. The square waves of one half cycle are transmitted by 1 on one frequency and 0 by the shift frequency. The other half cycle is transmitted similarly by a separate channel. Similar to [Figure 13.4](#), the unblock logic permits operation on internal faults if the channel signal is not received. The transfer trip mode is used in general for the audio tone-type channels.

Another technique for the comparison of the single-phase voltage from the sequence networks at the terminals is by pulse-period modulation. In this instance, the carrier period is varied linearly with the modulating signal amplitudes. A modulator develops the pulse train and the demodulator translates the pulse train into a magnitude wave. A delay equalizer ensures time coincidence of the local and remote signals. The channel can be either audio tones or optic fiber.

13.10 SEGREGATED PHASE COMPARISON PILOT SYSTEMS

As indicated in [Chapter 12](#), phase comparison pilot systems are preferred for the protection of series-compensated transmission lines. Dual-phase comparison systems are in service with favorable operating records. However, these types of lines can have very severe harmonics, so it is possible that networks, to provide the current-derived operating voltages, will provide incorrect information on the potential highly distorted current waves from faults on the system. These networks basically are “tuned” to the 50 to 60 Hz current waveform.

Accordingly, a system that compares the phases individually, rather than a single voltage for the three phases, is used. The voltage derived from the single-current magnitude is independent of power-system frequency and waveform. However, multiple channels are required in these systems. The two common systems are (1) comparing $I_a - I_b$ at the terminal ends over one channel, and $3I_0$ at the terminals over another channel; or (2) comparing each phase current I_a , I_b , and I_c at the terminals through three channels. The current square waves are compared basically as described for other types of phase comparison systems.

13.11 SINGLE-POLE-SELECTIVE-POLE PILOT SYSTEMS

The large majority of faults on the higher-voltage overhead transmission lines result from overvoltage transients induced by lightning. These cause a

flashover of the phase(s) generally to ground, and most faults are single-phase-to-ground. These can be cleared frequently by rapidly opening the circuit or faulted phase. Besides, because the transient has passed, the arc will be extinguished by deenergizing. Then, rapid automatic reclosing will restore service. This is discussed further in [Chapter 14](#).

With the large percentage of single-phase-to-ground faults, it would be necessary to open only the faulted phase, leaving the other phases closed to exchange synchronizing power between the terminals. This technique is known as single-pole trip-reclose. On reclosing the opened phase, if the fault persists, all three phases are opened and further reclosing is blocked.

A more sophisticated scheme opens one phase for single-line-to-ground faults, two phases for line-to-line and double-line-to-ground faults, and three phases for three-phase faults. High-speed reclosing occurs for one or two opened-phase faults and is optional for three-phase faults.

The advantages of opening one or two phases are higher stability limit capability and less “shock” to the power system. During the open phase(s) period, zero-sequence and negative-sequence currents flow; therefore, ground backup relays must be set to avoid operation. The most appropriate open times are on the order of 0.5 to 1.0 sec.

Pilot relaying is necessary when high-speed reclosing is used to provide reasonable assurance that all terminals are opened to deionize the fault. The schemes for single-pole and selective-pole relaying are more complex. Several techniques are used for selecting the faulted phase; and a discussion of these is beyond the scope of this book. Most of the schemes have difficulties with some types of faults for which they are not designed to operate, so additional relays or auxiliaries are required to avoid incorrect operations. The three-subsystem segregated phase comparison scheme of the preceding section provides an excellent means for single-pole or segregated-pole relaying. This type opens only the faulted phase or phase involved in the fault, and with its independent comparison of the three phases, the scheme avoids the difficulty of correctly identifying the phase(s) that is faulted, which plagues many other schemes.

Single-pole-trip-reclose systems are common in Europe, but are used infrequently in the United States. The main reason was that until the advent of EHV, the U.S. circuit breakers were three-pole type, with only one trip coil. Thus, to apply single-pole-reclose relaying, special or more expensive breakers were required. With separate pole mechanisms now common, there is increased interest in these relaying systems.

The most important application for these systems is for the single line connecting two major power sources with no other or weak ties between them. Three-phase trip-reclose cannot be used for these, as the two systems are separated by opening the line and will be too far out of synchronism to reclose and maintain stability.

13.12 DIRECTIONAL WAVE COMPARISON SYSTEMS

An electrical disturbance generates traveling waves that spread outward from the disturbed area, traveling down the line in opposite directions. If the disturbance is between the line terminals (an internal fault), the wave direction will be out of the line at both terminals. If it is an external fault, the wave direction will be in at one terminal and out at the other. Thus, comparing the wave direction at the terminals by a microwave or power-line carrier channel provides an indication of a fault and its location. A decision is made in the first 2 to 5 msec, ignoring all later information. Only sudden changes are recognized, steady-state or slow changes are suppressed.

This provides ultrahigh-speed distance protection for lines of 350 kV and more.

13.13 DIGITAL CURRENT DIFFERENTIAL

The previously described pilot wire relaying and phase comparison systems are forms of current comparison pilot systems. Pilot wire schemes are classified as current differential scheme in that, information is derived from the currents at each line terminal to develop a voltage signal that contains information that relates to the magnitude and phase of each of the currents at the associated line terminals. The voltage signals are carried over the pilot wire and are compared at each terminal. Percentage differential relays located at each line terminal respond to currents that are derived from signals compared at each terminal. Application problems of the metallic pilot wire have restricted the use of such pilot wire systems to very short lines. Replacement of the metallic pilot wire with fiber-optic cable has allowed utilities to upgrade the performance of existing pilot wire systems, however, such systems are rarely used for new installations. The availability of communication systems that are capable of exchanging digital data has allowed the application of digital line differential systems. In such systems, samples of the current at each terminal are converted to a digital signal. The digital signals are transmitted between terminals using a wide band channel and compared to determine if a fault exists within the protected line section.

13.14 PILOT SCHEME ENHANCEMENTS

Various enhancements are applied on pilot relay systems to improve performance.

13.14.1 TRANSIENT BLOCKING

Overreaching pilot relays on unfaulted lines can operate for external system faults that are within their reach. When such operation occurs, one terminal of the pilot relay scheme on the unfaulted line is set up for a trip subject to

receipt of the tripping signal from the other terminal(s). During the process of clearing the system fault, one terminal of the faulted line may open before the opening of the other terminal(s) of the faulted line. When the first breaker of the faulted line opens, it is possible for the current through unfaulted lines to reverse the direction. If such a reversal occurs in a line in which an overreaching pilot relay had operated on the initial fault, it is essential that the picked-up overreaching relay drops out before the receipt of the trip signal, which would be initiated by the current reversal. If the trip signal is received before the dropout of the overreaching relay, an incorrect trip of the unfaulted line will result. Parallel lines are highly susceptible to such current reversals. Special logic is designed into pilot schemes that use overreaching relays to prevent such incorrect operations. This logic typically blocks pilot tripping at a terminal when it is recognized that the overreaching pilot relay had operated without receipt of the trip signal within a given time frame. The time setting for the transient blocking function must be longer than the maximum time that the receipt of the trip signal would be expected for an internal fault and less than the shortest time expected for a breaker operation on an external fault plus the time for the trip signal to be initiated and received at the terminal of the unfaulted line at which the overreaching relay had originally operated.

13.14.2 WEAK INFEED LOGIC

When a weak source exists at one terminal of a transmission line, it is possible for insufficient energy to exist at that terminal to operate forward-looking trip relays for a internal line fault. In such cases, the relaying at the weak source terminal will not operate until the breaker at the other line terminal(s) opens. Permissive or unblocking pilot schemes would not operate under such conditions as the scheme logic requires operation of fault relays at all terminals in order for a trip to be initiated at any terminal. Weak infeed logic can be incorporated into pilot schemes such that when the trip signal is received at a terminal and forward- or reverse-looking relays have not operated at that terminal, the trip signal is keyed and sent to the remote terminal(s), allowing the breaker to trip at that location. Sending of the trip signal from the weak infeed terminal can be supervised by zero-sequence and undervoltage relays to verify that a fault does indeed exist on the power system.

13.14.3 “BREAKER OPEN” KEYING

Permissive or unblocking schemes will not operate for an internal fault when the line is operating with one terminal breaker open as fault relays will not have operated at the open breaker position. For all such pilot schemes to operate under such conditions, a trip signal is automatically transmitted from the open breaker terminal. Keying of the trip signal is usually initiated by an auxiliary switch on the breaker, indicating that it is in the open position.

When a line terminates on two breakers, both breakers must be open in order for the trip signal to be sent.

13.15 TRANSFER TRIP SYSTEMS

Such systems are used to transfer a tripping signal to circuit breakers or other circuit interrupters that are located at an area remote from the protective relays. This is necessary either (1) because a breaker for fault isolation does not exist at the local station, or (2) for backup to ensure that the remote terminal is opened for system faults.

The term *transfer trip* is used in two contexts, which can be generally described as *equipment transfer trip* or *line-transfer trip*. A common example of equipment transfer trip is the installation of a transformer bank without a local breaker associated with one winding and where fault current can be supplied through that circuit to an internal transformer fault. This was discussed in [Chapter 9](#). Operation of the transformer protection can directly trip the local breaker(s), but a transfer trip system is required to open the remote breaker(s), especially when the current through the remote terminal is too low to operate FDs at that location. An alternative to transfer trip in this application is a local fault switch actuated by the local relays to assure fault current levels are well above the pickup values of the remote protection.

Transfer trip signals can be sent through any of the channels indicated earlier. Because high-speed operation of the remote terminal is desired, it is important that the channel and equipment used have very high security against transient operation from any spurious signal. FDs at the remote terminal generally cannot be used to supervise the transfer trip signal because of the possibility of a low-fault contribution.

Audio tone transfer trip systems are in wide use, generally with two separate systems for increased security. Signals from both systems must be received to trip the remote breaker(s).

In the line-transfer trip systems, FDs are used at the terminals. Thus, tripping can be initiated only after the local FD has operated and a transfer trip signal has been received. Consequently, channel security, although important, is not quite as critical as for the equipment transfer trip systems. Line-transfer trips are described in [Section 13.6](#) and [Section 13.7](#).

13.16 COMMUNICATION CHANNELS FOR PROTECTION

A variety of channels is used for protection. This is a field in itself, and is outlined only as necessary for a discussion of the protective systems. Historically and currently, channels generally have been the weakest link in the protection chain. Tremendous progress has been made from the early applications in the 1930s to the quite sophisticated and highly reliable equipment

available in recent times. This is a specialized field, and applications for protection should be made by specialists in this area, who are familiar with the protection requirements. Good engineering for channels is mandatory for secure and dependable protection, as it is for the relay protection part.

13.16.1 POWER-LINE CARRIER: ON-OFF OR FREQUENCY-SHIFT

Beginning in the early 1930s radio frequencies between 50 and 150 kHz were superimposed on the power lines for pilot protection. They were originally used in an on-off mode and, as the art progressed, frequency-shift became available. These are known as power-line carrier channels and are in wide use with frequencies between 30 and 300 kHz. Figure 13.7 illustrates a typical channel of this type. In the United States, phase-to-ground coupling is most commonly used. Other types used are phase-to-phase, two-phase-to-ground, and so on. The transmitters generate about 1–10 W of radiofrequency (RF) power. In the past, 100 W transmitters were available, but they are not in common use currently.

The RF signal is connected to the high-voltage line through a line tuner and coupling capacitor, as shown. The tuner, normally mounted at the base of the coupling capacitor unit, cancels the capacitance of the coupling capacitor unit. This provides essentially a low-impedance resistive path for efficient transfer of RF signals to and from the line section.

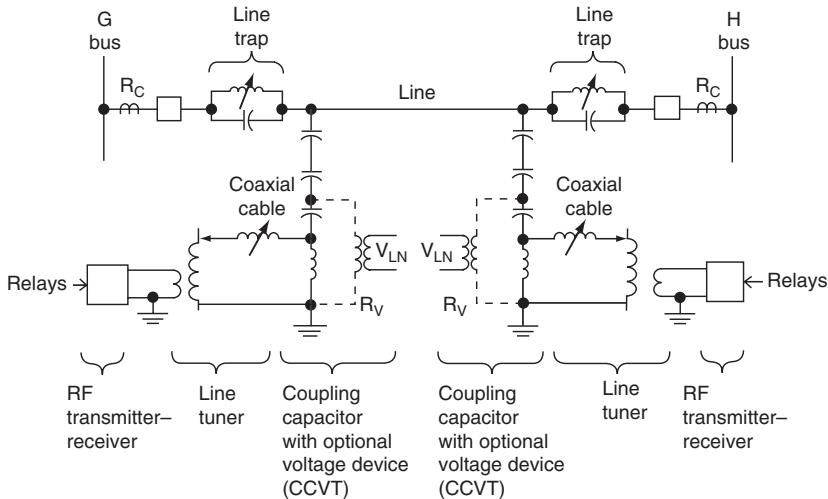

FIGURE 13.7 Typical single-line diagram for a phase-to-ground power-line carrier channel.

At the remote end, the RF energy passes through similar equipment to the receiver. The transmitter–receiver may be tuned to the same frequency or to different frequencies, which may require a double-frequency tuner.

The inductance between the coupling capacitor and ground presents a high impedance to the RF signal, but low impedance to the system 50 or 60 Hz. This unit may also supply secondary voltage as CCVTs, in which case, three are used to connect individual phases, and only one is used for coupling, as shown.

A line trap is connected in the high-voltage line at each terminal just external to the RF path. It is tuned to provide a high RF impedance, to minimize signal loss into the buses and associated systems, and to prevent external ground faults from potentially shorting out the signal. Traps are available for tuning to a single frequency, double (two) frequencies, or to a broad band of RF frequencies. They are designed to carry a 50 to 60 Hz-load current continuously at low loss, and to withstand the maximum fault current that can pass through the line.

Although the RF signal is introduced to one of the phases, it is propagated by all three-phase conductors. There have been several occasions when the accidental coupling to different phases at the two terminals has gone unnoticed for several years because an adequate signal was received. In fact, the signal may be greater when coupled to different phases. Model analysis has provided an important modern tool for predicting carrier performance and the best method of coupling and transmission. This is important, especially for long lines. The references provide more information on this.

Overhead power lines tend to have a characteristic impedance (Z_0) between 200 and 500 Ω phase-to-ground and 400–488 Ω between phases. The carrier equipment and coupling particularly match these values for maximum power transfer of the RF. Taps and discontinuities, particularly if they are at quarter wavelengths, can result in high signal losses. The RF signals should be selected to avoid these problems.

Power-line carrier applications to power cables may be impossible or very difficult, as their characteristic impedance is low and the losses are higher than that for overhead lines. Carrier transmitter–receivers are operated on–off, frequency-shift with mark-space signals, or single sideband, depending on the design and application.

Fault arc noise has not been a problem or a significant factor in the use of power-line carrier for protection. Disconnect switches with currents less than 200 A can cause operation of carrier on–off receivers, but this does not impair the protection used with this type of equipment.

13.16.2 PILOT WIRES: AUDIO TONE TRANSMISSION

Audio tones in the range of 1000–3000 Hz are used for protection. They are more compatible for use over leased telephone facilities and, therefore, they

are frequently applied over these channels for protection. The protection hazards and solutions outlined earlier are applicable. When used, neutralizing transformers should be able to pass the audiofrequencies with low losses. Frequency-shift, on-off, and pulse-code equipment is available.

13.16.3 PILOT WIRES: 50 OR 60 HZ TRANSMISSION

One of the early and still used channels is a twisted pair of “telephone” wires to provide a low-voltage, low-power continuous circuit between the protected zone terminals. Preferably, wires on the order of AWG 19 are desired both for mechanical strength and to provide loop that is not more than about a 2000 Ω for two terminals or not more than 500 Ω per leg for three-terminal applications. It is mandatory that they be twisted pairs, to minimize extraneous voltage differences between the pair from signals on other pairs in the cable and from external voltages outside the cable.

The problems that are experienced with pilot wires result from induction from lightning or a paralleled power circuit, insulation stress from a rise in station ground-mat voltage during faults, direct physical contact by lightning or with the power circuit, physical damage by insulation failure, or gunfire directed at overhead circuits. (For protection, see [Appendix 13.1](#).)

13.16.4 DIGITAL CHANNELS

In recent years, digital channels are increasingly used for pilot relaying communications. Some of the types of digital channels that are used for this function include dark fiber (dedicated fiber-optic cable), multiplexed fiber-optic systems (T1 and SONET), digital microwave, radio links, and 56 kbps phone lines (Digital Data Service). Digital microwave can be point-to-point or used within a SONET ring.

Digital communication systems are a study in themselves and are beyond the scope of this book. It is important, however, for protection engineers to become familiar with this area as digital communication systems continually play a large role in modern protective systems. The large amount of control wiring that was required within substations for protection and control is replaced in many cases with digital communication systems with the application of microprocessor based relaying. Practically all modern microprocessor relays have built-in digital communication capability and ports for sending and receiving digital messages.

With respect to pilot relay systems, the optimal digital channel performance can be obtained from a dedicated fiber pair. The dedicated pair is virtually immune from electrical interference, has a very low bit error rate, and a very short end-to-end data delay time. Such application, however, is very expensive and can be prone to long outages if the fiber is cut.

Multiplexed digital networked systems offer the advantage of very low outage rates. In such systems, if a path is lost, an alternate route is

automatically and quickly inserted. Such systems are also more economical than dark fiber because up to 24 channels can be multiplexed on a single fiber pair. Delay times and time to switch over to an alternate path need to be considered when applying multiplexed digital communication systems. The normal magnitudes of delay and switchover times involved, however, usually do not prevent the use of multiplexed communication systems in pilot schemes that use digital relays.

Digital microwave is suitable for pilot relaying schemes in that the channel delay times are very short (500–600 μsec). A concern with using digital microwave is its tendency to fade during inclement weather conditions—it is during these types of conditions that faults are most likely to occur on the power system!

Some of the important parameters that need to be considered when applying digital communication systems in pilot relay schemes include the following:

1. Delay time from end-to-end. The pilot system must be capable of dealing with variations in delay times that exist in many digital systems. A difference could exist between the delay time involved in sending a signal and that involved with receiving a signal. Delay times can also change when alternate paths are inserted.
2. Interruptions to the communication channel. The system must be designed to be capable of resynchronization following a switching operation on the communication network.
3. Excessive bit errors. High attenuation caused by long distances can result in bit error rates that are very high for obtaining satisfactory operation of a pilot system. Moreover, copper links can exist within communication networks resulting in the possibility of electrical interference.

Replacement of wire pairs used in electromechanical pilot wire schemes must have very short end-to-end delays. These older pilot wire systems were not designed to account for any channel delay. In such applications, channel delays less than 1 msec are desirable and channels with delays more than 2 msec should not be considered.

Experience has shown that digital channels that are available from telephone companies through channel service units (CSUs) are not suitable for protective relaying applications. As the CSU is not hardened for use within a substation, nearby faults can cause the channel to be lost. Periodic interruptions, long delay times (greater than 20 msec), and asymmetrical delays are other problems that have been encountered when attempted to apply such systems in relaying schemes.

13.17 SUMMARY AND GENERAL EVALUATION OF PILOT SYSTEMS

Field experience over many years has indicated that all the pilot system types can, with proper design, provide good reliability. Thus, the choice, if there are no application restraints or limitations, is largely one of personal preference and of economics. Within the various types of pilot systems, the following general tendencies and comments can be observed.

The blocking systems tend toward higher dependability than security. Failure to establish a blocking signal from a remote terminal can result in overtripping for external faults.

On the other hand, transfer trip systems tend toward higher security than dependability. A failure to receive the channel signal results in a failure to trip for internal faults. The transfer trip systems require extra logic for internal-fault operation at a local terminal when the remote terminal breaker is open, or for a “weak feed,” when the fault contribution is too low to send a trip signal. This is not a problem with blocking and unblocking systems.

Unblocking systems offer a good compromise of both high dependability (channel not required to trip) and high security (blocking is continuous).

The directional comparison blocking system is most adaptable to multi-terminals or taps on the line. A weak feed, with its very low-fault contribution to internal faults, does not prevent the other terminals from tripping. However, tripping the weak-feed terminal may require a separate transfer trip system and channel. For nonsource taps where the relays at the other terminals cannot be set selectively with the tap, a blocking-only terminal at the tap can be used to block remote terminal tripping for external faults at the tap.

Historically, directional comparison systems use the same distance relays for both pilot primary and for zone 1 and backup protection. Phase comparison offers complete independence between the pilot and backup and the possibility of not being dependent on system voltage measurement.

In EHV and UHV protection, where two pilot systems are commonly used, one directional comparison and one phase comparison system provide two completely different types, which can appear attractive. However, to some this can be a burden—two different systems to be familiar with and to maintain.

Schemes that operate on current alone such as phase comparison, charge comparison, and current differential are suitable for the protection of complex transmission configurations because performance is good on evolving inter-circuit and cross-country faults. Such systems are also immune to mutual coupling, power switching, and series impedance unbalances. These schemes can provide good protection for cables, series compensated lines, short lines, and lines with greater than two terminals.

Pilot wire relays are recommended and widely applied for short lines such as those that exist in utility distribution and industrial plant complexes. Experience over many years indicates that nearly all problems are pilot wire related, often the result of inadequate design, protection, or maintenance. When these are resolved, the performance is very high. Fiber-optic pilot circuits offer the advantage of having no electrical-related problems.

All types and combinations of pilot channels are in use. The choice is based primarily on availability and economics moderated by personal preference. Power-line carrier has been in use for many years and has the advantage that the channel is under the control of the protection group or within the user company. However, available frequencies can be a problem, as the spectrum is crowded. Frequencies can be repeated within the system where interference does not occur. These RF frequencies are not licensed and therefore they may be used by outside users in the area.

Microwave channels are used where they are available or justified for other uses. They are normally owned by the channel user.

Audio tones on leased or private-line channels have good operating records when the associated telephone lines are suitably conditioned for application in protective relaying schemes. It is important that the leasing company be aware of the critical nature and requirements of protection channels.

Digital communication systems are used with great success for many of the new installations. Such systems, when properly designed and applied, provide a very high level of reliability. As digital channels become more readily available and economical, it is likely that digital will be the predominate choice in the future.

It is interesting to observe again that all systems are in use. Where two pilot systems are applied, there is no one particular combination that appears to predominate. All of which again emphasize that relaying is largely a matter of “personality.”

13.18 PILOT RELAYING—OPERATING EXPERIENCES

As noted earlier, from a technical standpoint, pilot schemes can be designed for high reliability. Nevertheless, over the years, obtaining satisfactory performance from such systems has been a major challenge to protection engineers. Operating speed and security are both important objectives that are sought when such schemes are applied. Unfortunately, these objectives are conflicting in nature. Increased speed improves protection of equipment and enhances system stability margins. When steps are taken to increase operating speed, however, an increase also results in the probability of the scheme operating incorrectly.

Experience has shown that the performance of the associated communication systems plays an important role in the overall performance of pilot relay systems. Over the years, analysis of misoperations involving pilot

systems often points to a failure in the communications system as the cause of the problem. In some cases, communication systems are merely improperly applied relative to the needs of the pilot scheme. Protection engineers are not communication experts and communications personnel are often unfamiliar with protective systems. However, over time, communications equipment, associated wiring, and integrity of connections can deteriorate, causing gradual degradation of channel performance. Performance of a communications channel can also change based on environmental and weather conditions. Degrading and variations in channel performance are often difficult to detect before misoperations occur.

To illustrate the problems mentioned earlier, the following presents several examples of actual experience with pilot relay problems:

The 1960s saw a considerable expansion of new transmission facilities across the country on account of high and increasing demand rate for electric power. A policy of a utility in the eastern part of the United States was to use audio tone channels over leased telephone circuits for a large portion of the pilot schemes installed on its rapidly growing number of transmission circuits. Audio tone schemes usually provide an option such that tripping by the associated pilot relay scheme is blocked while noise is detected on the related telephone circuit. Such a blocking system is referred to as “squelch.” The protection philosophy at this particular utility was not to use the squelch option to prevent the possibility of it delaying the tripping time of the pilot system. It was felt that occasional misoperations were preferable to the risks associated with slow clearing times. As the system expanded, performance of the audio tone pilot schemes deteriorated to the point that misoperations were experienced on a regular basis. A staged fault test verified that the problem was caused by severe noise induced into the telephone circuits during fault conditions. At the risk of losing business, the telephone company offered to provide specially conditioned circuits that would be highly immune to noise and meet the needs of the associated relaying system. Application of the conditioned circuits greatly improved performance, however, over time, a dropoff in performance was again noted probably on account of deregulation of the communication industry and a general apathy toward providing special service to a very small portion of its business.

The impact of maintenance practices has also had a significant impact on the performance of pilot relaying. Deregulation of the power industry had caused many utilities to become highly cost conscience and expenses for maintenance became a prime target for cutting costs. An investigation of incorrect relay operations in a large interconnected area over many years had shown that an increase in pilot scheme misoperations was experienced when maintenance of these schemes was reduced or postponed. The increased rate of misoperations did not occur immediately but gradually over time and at an increasing rate. The involved utilities were not willing to admit to a poor policy decision until performance degraded to a point that it was not unusual

for several lines to trip on a single line fault. Many of the misoperations were traced to improper blocking action of the communication system that was involved with directional comparison blocking pilot schemes. Resumption of adequate maintenance and replacement of deteriorated equipment had a very positive impact on pilot scheme performance.

The availability of digital relays and communications systems created an opportunity for protection engineers to provide pilot systems with inherent higher reliability. Digital system developments and application experience have shown that significant reliability improvements are indeed available with such applications. Application of digital technology, however, presents some new challenges to the protection application engineer. Familiarity with a new technology needs to be developed. Instruction booklets for digital relays tend to be thick and sometimes difficult to understand. The systems require considerable programming, which can be complex and subject to error. Relay products are continually changing or existing models upgraded over time. In such an environment, it has become increasingly difficult to maintain standards that can be carried over from station to station. Moreover, the protection engineers find themselves continually analyzing new products and developing new designs for their protective systems. A need for good records, which document all settings, logic programming, and version upgrades of equipment in service has become imperative to avoid mistakes that could result in failures of the protection systems to operate properly.

BIBLIOGRAPHY

See the Bibliography at the end of [Chapter 1](#) for additional information.

ANSI/IEEE Standard C37.93, Guide for Protective Relay Applications of Audio Tones Over Telephone Channels, IEEE Service Center.

Bayless, R.S., Single phase switching scheme protects 500 kV line, *Transmission Distribution*, 35, No. 1, 1983, pp. 24–29, 47.

Bratton, R.E., Transfer trip relaying over a digitally multiplexed fiber optic link, *IEEE Trans. Power Appar. Syst.*, PAS 103, 1984, pp. 403–406.

Chamia, M. and Liberman, S., Ultra high speed relay for EHV/UHV transmission lines—development, design and application, *IEEE Trans.*, PAS-97, 1978, pp. 2104–2116.

Crossley, P.A. and McLaren, P.G., Distance protection based on traveling waves, *IEEE Trans.*, PAS-102, 1983, pp. 2971–2982.

Edwards, L., Chadwick, J.W., Riesch, H.A., and Smith, L.E., Single pole switching on TVA's Paradise-Davidson 500 kV line—design concepts and staged fault test results, *IEEE Trans. Power Appar. Syst.*, PAS 90, 1971, pp. 2436–2450.

IEEE Standard 281, Service Conditions for Power System Communications Apparatus, IEEE Service Center.

IEEE Standard 367, Guide for the Maximum Electric Power Station Ground Potential Rise and Induced Voltage from a Power Fault, IEEE Service Center.

- IEEE Standard 487, Guide for the Protection of Wire Line Communication Facilities Serving Electric Power Stations, IEEE Service Center.
- Shehab-Eldin, E.H. and McLaren, P.G., Travelling wave distance protection, problem areas and solutions, *IEEE Trans. Power Deliv.*, Vol. 3, July 1988, pp. 894–902.
- Sun, S.C. and Ray, R.E., A current differential relay system using fiber optics communication, *IEEE Trans. Power Appar. Syst.*, PAS 102, 1983, pp. 410–419.
- Van Zee, W.H. and Felton, R.J., 500-kV System Relaying, Design and Operating Experience, CIGRE, 1978, Paper 34-7.

Appendix 13.1

Protection of Wire-Line Pilot Circuits

Optic-fiber channels eliminate the electrical hazards of induction, station ground rise, and insulation, which have been the major problem in the use of direct metallic wires. Yet, these channels are in use and will probably continue to be in use. Thus, a review of wire pilot-line protection is in order.

Surge arrestors can be used for equipment surge protection as appropriate. Insulation problems generally can be detected by supervisory equipment together with good maintenance and inspection procedures. Mutual induction and station ground-rise voltages can be controlled by proper design.

The best pilot wire channel is one with adequate insulation and shielding to withstand induced voltages or ground station rise if possible. Grounded metallic shields with pilot cables or supporting messenger wires can provide about 50% reduction in induced voltage.

Mutual induction occurs when fault current, primarily the $3I_0$ component, flows through the transmission line that is in parallel with the pilot pair. An example is shown in [Figure A13.1-1a](#). A voltage equal to $I_F Z_M (3I_0 Z_{0M})$ is induced in the pilot pair between the wires and ground. If the pilot pair is not grounded, this voltage exists across the pair as illustrated in [Figure A13.1-1b](#). This assumes uniform exposure along the line and that I_F is for a fault near or at either bus G or bus H. If the gaps flash or the insulation breaks down at one terminal, such as bus H, the full induced voltage will appear at the other end, as shown in [Figure A13.1-1c](#).

If protective gaps at both ends break down, the induced voltage causes current to circulate over the two pilot wires in parallel and ground, and thus reduces the voltage to a low level. Telephone gaps, carbon blocks, and gas discharge tubes are used. With 3 mil gaps and gas tubes, the usual breakdown voltages are 400 to 500 V; 6 mil gaps have breakdown of about 850 V.

For protective relay applications, it is mandatory that a mutual drainage reactor be used with the gaps or tubes. The typical connections are illustrated in [Figure A13.1-1d](#). These reactors force simultaneous breakdown of both gaps. Otherwise, the breakdown of one gap before the other will result in a momentary voltage between the pair and is sufficient to cause undesired and

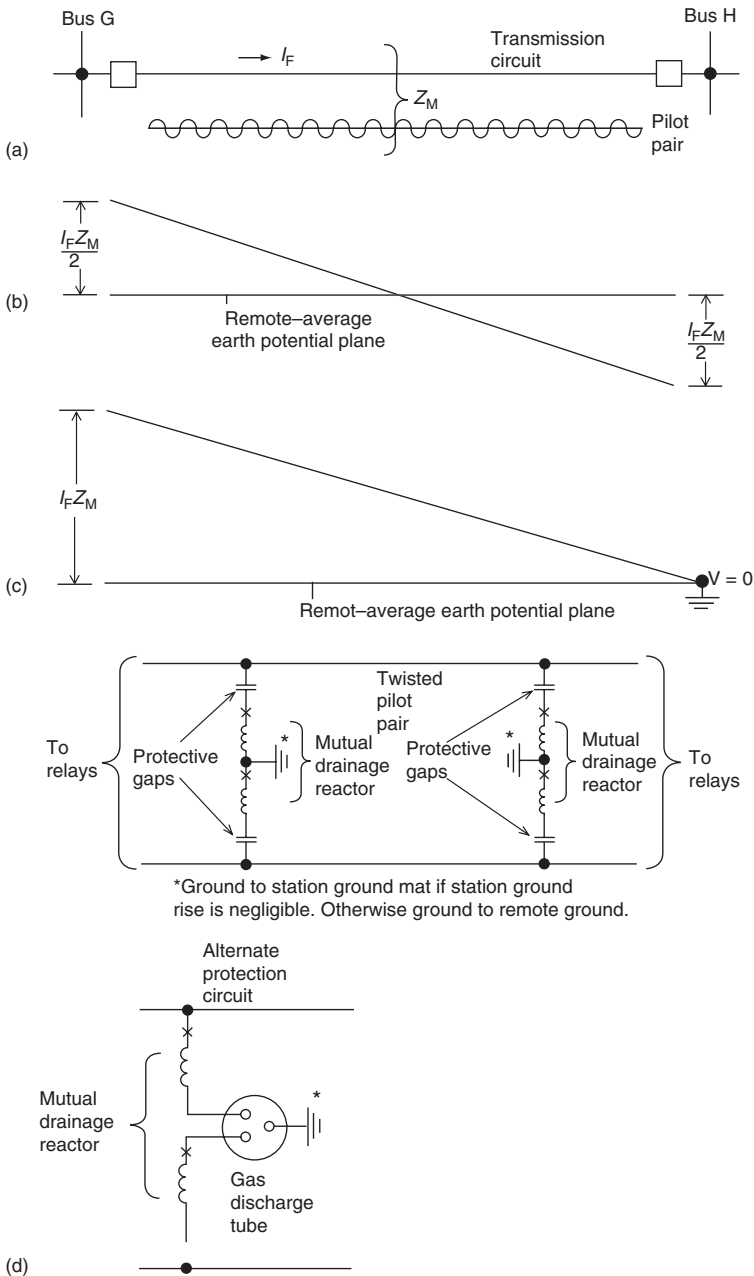

FIGURE A13.1-1 Typical voltage induction in a paralleled pilot circuit: (a) a pilot pair paralleling a transmission circuit; (b) mutual induction voltage profile for uniform induction and pilot pairs ungrounded at both terminals; (c) mutual induction voltage profile for uniform induction and pilot pairs grounded at bus H terminal; (d) mutual induction voltage reduced by circulation over the pilot pair and ground after protective gaps flash over.

incorrect operation of high-speed relays. As indicated, twisted pairs are necessary to keep this voltage difference between pairs to a small value.

Station ground rise is illustrated in Figure A13.1-2. The return path for a ground fault is illustrated approximately in Figure A13.1-2a. If the fault is within the area of the ground mat, most or all of the return current will be

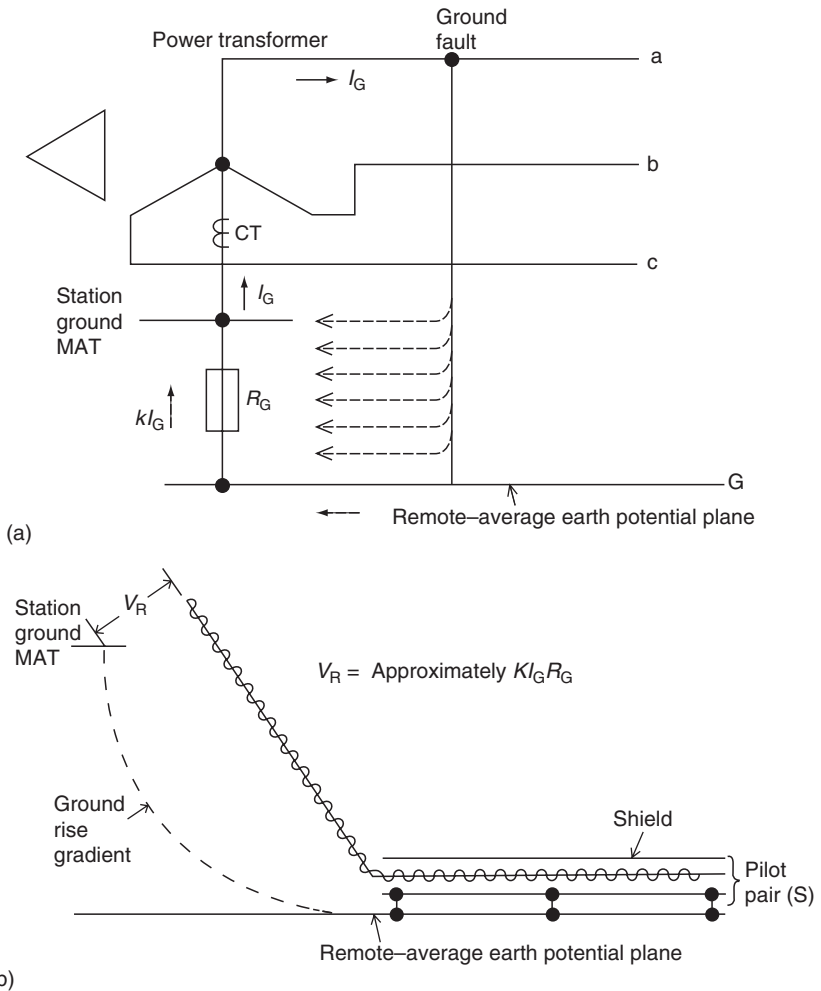

FIGURE A13.1-2 Station-ground-mat voltage rise during system ground faults: (a) Phase-to-ground fault and the current return paths. (b) Pilot circuit entering station subject to the ground rise voltage. (Continued on next page.)

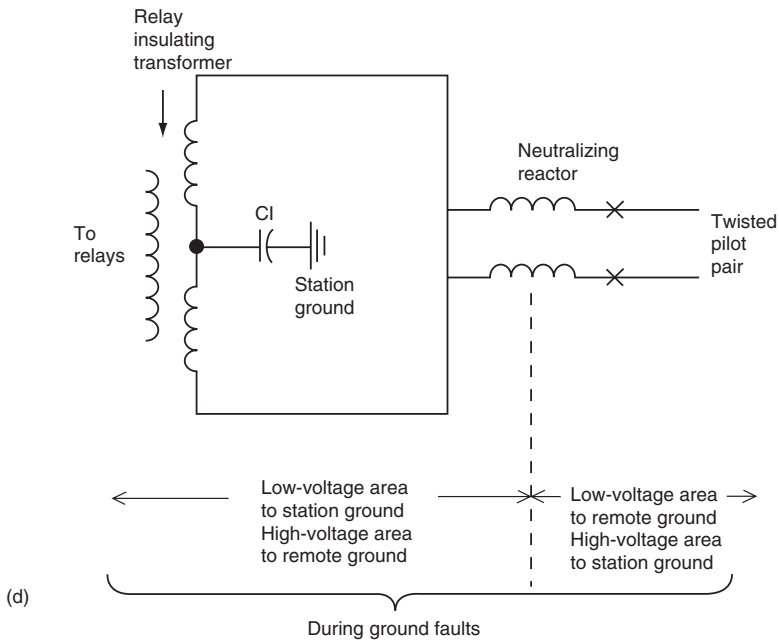
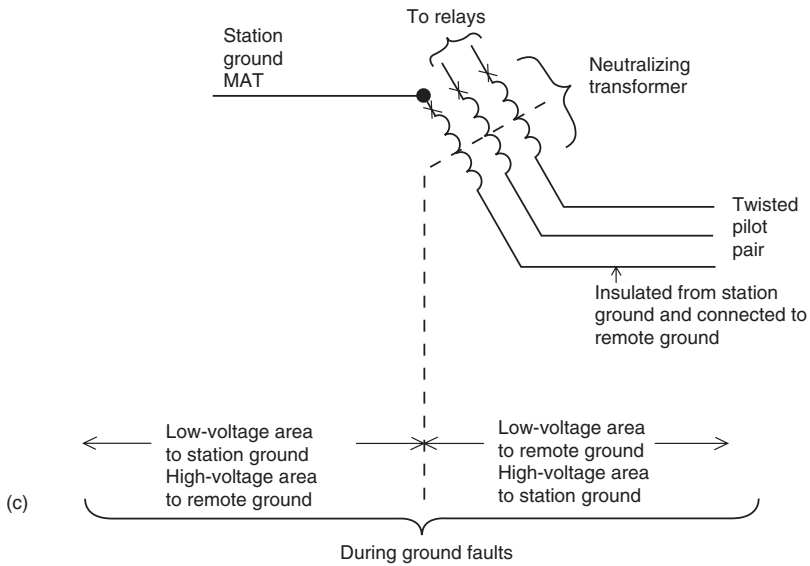

FIGURE A13.1-2 (continued) (c) Three-winding neutralizing transformer application. (d) Two-winding neutralizing transformer application.

through the mat to the transformer bank neutral. For faults outside the ground-mat area, a great deal or all of the current will return through the resistance represented by R_G between the ground mat and remote ground. R_G is the summation of many parallel paths of contact between the station-grounding network and a nonuniform earth. Station-ground-mat design and its grounding is a complex subject with many variables and assumptions. The objective is to keep both the impedance across the mat and to the remote earth as low as possible. Physical measurement of R_G is quite difficult.

During a ground fault, there will be a voltage difference between the ground mat and remote earth of $kI_G R_G$. This can be quite large, with high values of current or ground resistance.

Equipment that enters the station from outside, such as communication cables, can be subject to this voltage, as illustrated in [Figure A13.1-2b](#). All grounded shield circuits should be terminated outside the station if there is the possibility of a significant voltage difference during faults. The pilot pairs that must enter the station will be subject to this voltage rise. Although the pair may not be grounded to remote earth physically, it can be essentially at remote earth potential due to the distributed capacitance of the pair and earth. Generally, the rise is expressed as the maximum $I_G(3I_0)$ current for a fault immediately outside the station times the measured or calculated ground resistance (R_G). This represents a maximum value that may not be realized in actual practice. The insulation of the cable and associated terminating equipment must be able to withstand this rise, or neutralizing devices must be applied.

The two types of neutralizing transformers generally used are shown in [Figure A13.1-2c](#) and [Figure A13.1-2d](#). In c, the primary winding is connected between the station and remote earth to sense the station ground rise. This provides a neutralizing voltage across the secondaries so that the station terminals are at the station-ground-mat voltage, whereas the other end is at remote ground. For multiple pilot pairs, transformers with many multiple secondaries are available.

A two-winding neutralizing reactor applicable to a single pilot pair, used for protection, is shown in [Figure A13.1-2d](#). Capacitor C1 with equivalent capacitance along the pilot pair or at the remote end provides the exciting current and, hence, the exciting voltage across the windings equivalent to the rise in station ground.

It is important to recognize that with these devices normally mounted in the station environment, one end will be at remote ground and thus should be insulated and isolated from personnel contact. This would also be true of high-voltage cable entries without neutralizing devices. Pilot wires are usually limited to short distances, on the order of 15–20 miles or less.

14 Stability, Reclosing, Load Shedding, and Trip Circuit Design

14.1 INTRODUCTION

The emphasis in the preceding chapters has been directed toward the protection of the various components of the power system. In this chapter, we examine the operation of the power system as a whole or unit, how the protection is effected, and how relaying can be applied or modified to minimize system disturbances.

The normal operation of generating, transmitting, distributing, and using AC electric power is of little concern to the protection systems as long as the load current does not exceed the specified maximums. Regulating relays and equipment are involved, but these are beyond the scope of this book. However, faults, system abnormalities, sudden increases or losses of large blocks of load or generation, and loss of equipment cause power system disturbances that can affect the protection. Moreover, incorrect application, setting, or operation of the protection can result in system disturbances and loss of service.

14.2 ELECTRIC POWER AND POWER TRANSMISSION

Power in an electrical system is

$$P + jQ = \hat{V}\hat{I}e^{j\theta} = \bar{V}\bar{I}/\theta^\circ, \quad (14.1)$$

where P is the real power (W, kW, MW), Q the quadrature or reactive power (var, kvar, Mvar), \hat{V} the phasor voltage (V, kV, MV), and \hat{I} the conjugate phasor current (A, kA, MA), \bar{V} and \bar{I} are the scalar magnitudes, with θ the angle, at the point where the current lags the voltage. Thus, Q is positive for lagging reactive power, commonly designated simply as reactive power. Negative Q indicates leading reactive power. Power transmission across a system can be expressed in terms of sending-end power ($P_S + jQ_S$) and receiving-end power ($P_R + jQ_R$).

For simplification it is practical to neglect the resistance and losses over the system, so that

$$P_S = P_R = P = \frac{V_S V_R}{X} \sin \phi, \quad (14.2)$$

where V_S and V_R are the sending- and receiving-end voltages, ϕ the angle by which V_S leads V_R , and X the total reactance between V_S and V_R .

Equation 14.2 can be plotted as shown in [Figure 14.1](#). At no-load across the system, $V_S = V_R$, $\phi = 0^\circ$, and $P = 0$. The maximum power transfer occurs when $\phi = 90^\circ$ and is

$$P_{\max} = \frac{V_S V_R}{X}. \quad (14.3)$$

Thus, more power can be transmitted between parts of the system by (1) raising the voltage V_S , V_R , or (2) reducing the reactance X , or a combination thereof. The first is the logic for the higher-voltage systems (HV, EHV, and UHV). The second is accomplished by more interconnecting lines or connecting series capacitors in the line. Both are in use in a variety of combinations.

14.3 STEADY-STATE OPERATION AND STABILITY

The normal operation of the power system involves an exchange of power between the generators and the various loads. In the typical simplified system of [Figure 14.1](#), V_S and V_R may represent the voltages developed by generators supplying loads connected in the system, such as at buses G and H, or V_S can represent the voltage of generators and V_R the voltage of motor loads. Although the operations are similar in either case, the latter is easier to visualize. Assume an equilibrium state at a power level P' . With no losses, the mechanical input P'_{MS} to the generators equals their output, P'_{ES} . This is transferred across the system to equal the input P'_{ER} to the motors, which, in turn, equals the mechanical output of the motors, P'_{MR} . Thus, before any fault and with all lines in service, the electrical transmission requirements of [Figure 14.1b](#) show that V_S , the voltage responsible for direct synchronous reactance, leads V_R , the motor internal voltage, by ϕ' . When the load requirements change P' will increase or decrease and the system will adjust to a new operating angle ϕ . Steady-state stability is the ability of the system to adjust to gradual changes, and the limit is 90° for the two-machine no-loss system. Equation 14.3 defines the maximum power that the electrical system can transfer.

14.4 TRANSIENT OPERATION AND STABILITY

System faults, line switching, and the loss or application of large blocks of load can result in sudden changes in the electrical characteristics, whereas the

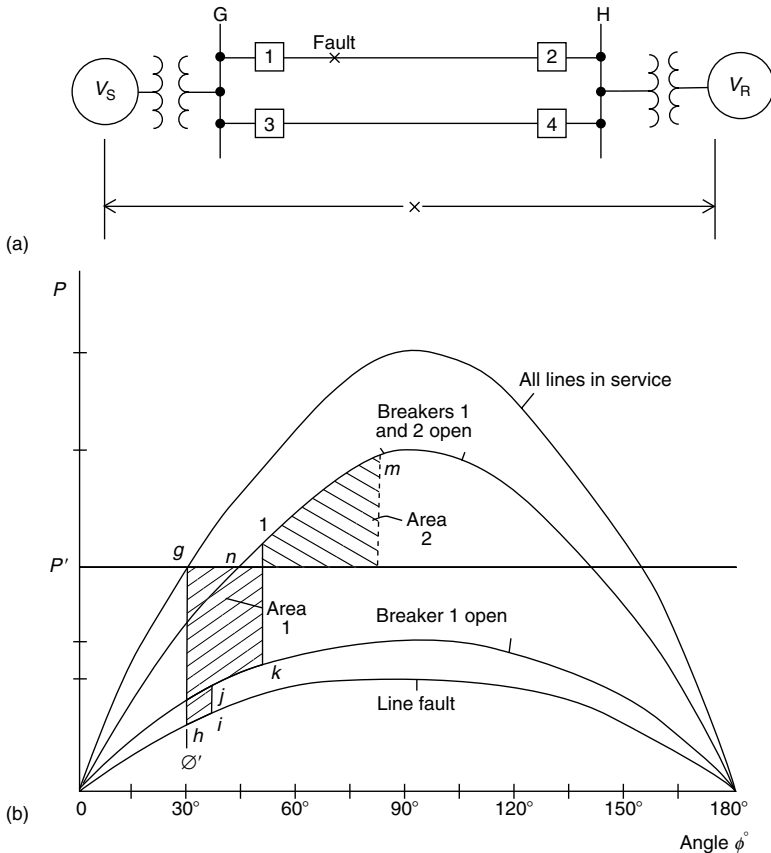

FIGURE 14.1 Typical power–angle curves for a simplified two-machine power system: (a) system diagram; (b) power–angle curves for various system conditions.

mechanical inputs and outputs remain relatively constant. It is important that the system readjust to these changes to continue operation and service. If the changes are too severe, instability results and the various parts of the system cease to operate together in synchronism. The resulting loss of synchronism or out-of-step operation requires that the parts be separated, stabilized, and resynchronized to continue complete service. Transient stability defines the ability of the power system to adjust to large and sudden changes.

The simplified two-machine system provides a good and adequate basis for understanding transient system operation and the interactions with the protection. A generator plant with a single tie to the power system or an industrial tie with rotating equipment and possibly generation to a utility are

basically two-machine systems. Most utilities, especially the large ones, consist of multiple generators at different locations, connected together by a network of lines and intermediate stations. Although their transient performance is more complex, the effect on the protection is similar to that of a two-machine system. Modern computer programs provide the necessary data for specific systems and operating conditions.

The most common sudden disturbance results from shunt faults. When a fault occurs, the transfer impedance X (see Figure 14.1), between V_S and V_R suddenly increases and instantly changes the power transmission capability of the system. For a fault out on line 1–2, the power–angle curve instantly moves from “all lines in service” to the “line-fault” curve. With prefault operation at power level P' and angle ϕ' , the change resulting from the fault reduces the electrical power transmission capability from g to h (see Figure 14.1b). The mechanical inputs and outputs are the same for a brief period, so the generator accelerates and the motor decelerates, both increasing the angle ϕ . The relays at 1 sense the fault and operate to open breaker 1, which changes the transmission capability to the “breaker 1 open” power curve. During this time to the opening of breaker 1, angle ϕ moves from h to i . Acceleration continues to increase angle ϕ from j to k when breaker 2 is opened by the relays at 2. This again changes the transmission capability, next to the power curve “breakers 1 and 2 open.” At 1, the electrical transmission capability is greater than the mechanical requirements, so the generators decelerate and the motors accelerate. Although the accelerating power goes through zero as k_1 crosses P' , the swing continues (angle ϕ increases) because the velocity of the rotating masses cannot be changed instantly. The shaded area 1 represents the kinetic energy added to the rotating masses, area 2, kinetic energy returned to the circuit. Thus, the swing will continue to m , where area 2 equals area 1. At m the swing reverses, oscillating below and above the mechanical requirement, line P' , with the final operating at n . This assumes no change in the power P' requirements. The oscillation is damped by the resistance in the system, the voltage regulator, and governor action.

The foregoing represents a stable system. If the area above the P' operating power line were lesser than area 1 below, the system cannot maintain synchronism and will go out-of-step. This represents an unstable system. Thus, it is desirable to keep area 1 as low as possible. This can be aided by fast relaying and breaker operation, and as discussed in Chapter 13, pilot protection provides this possibility. With high-speed simultaneous tripping and high-speed breakers, area 1 can be kept small, so that more power (P') can be transferred across the system without allowing its possibility to exceed area 2.

The type and location of the disturbance is an important factor. In Figure 14.1b system, the worse fault is a solid three-phase fault at bus G or bus H. In these situations, no power can be transmitted across the system during the fault. Usually, in a highly interconnected network, there will be multiple ties

between V_S and bus G, and between bus H and V_R , thus some power can be transferred for these three-phase solid faults. This is similar to a solid three-phase fault out on line 1–2, where the power–angle curve typically is as shown in the “line fault.” As three-phase faults are not too common, stability studies often use the two-phase-to-ground fault as the criterion. Reliability requirements as documented in standards issued by federal and state regulatory bodies and regional transmission organizations dictate conditions that need to be analyzed and for which stability must be maintained. Such standards also identify “maximum credible” conditions that require analysis to obtain a feel for the robustness of power systems by measuring its vulnerability to instability for highly challenging events even though their probability of occurring is very low.

The time for ϕ to change during system swings involves the solution of a second-order differential equation, which includes the inertia constants or characteristics of the rotating masses. A common method is a step-by-step solution where during short-time intervals the accelerating power and angular acceleration are assumed to be constant. This provides a time–angle curve or data where if the system is stable the angle eventually decreases after an increase in the initial disturbance.

The voltages and currents during a system swing, particularly during out-of-step operation, are shown in Figure 14.2. If we consider the simplified two-machine system, V_S is considered as fixed, with V_R as lagging relative to V_S .

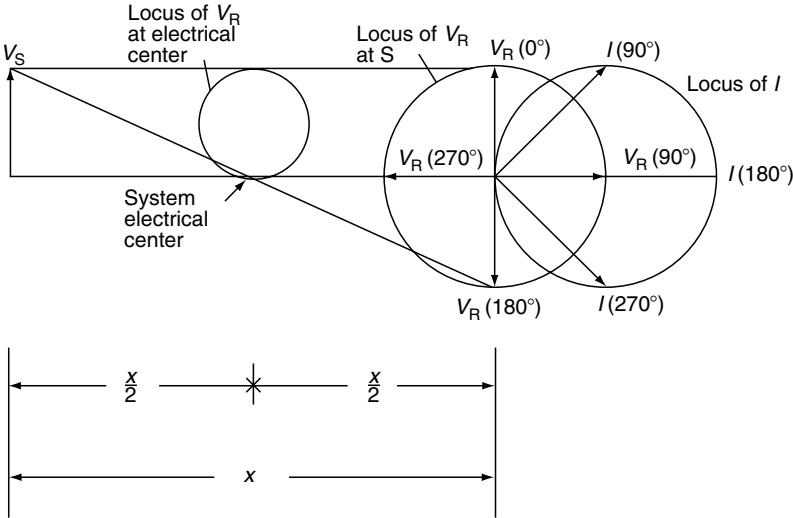

FIGURE 14.2 Typical two-machine system voltages and currents as V_R rotates relative to V_S .

For normal-load operation, V_R will lag, as defined by the system power–angle curve and the loading.

Because of a sudden large disturbance, V_R can swing to as much as approximately 120° in a stable system. If the system is unstable, V_R continues to lag and, at 180° a “pole is slipped,” synchronism between V_S and V_R is lost, and the two parts operate out of phase. This situation causes the voltage and current to fluctuate. The electrical center is the point in the system where the impedance to the two sources is equal. At this center, the voltage varies from maximum to zero, as shown by the locus circle. At other points, the voltage varies from maximum to the diagonal line between V_S and V_R at 180° . In the simple reactance system, the current changes from normal to about twice the normal when V_S and V_R are 180° out of phase. It should be recognized that during transient operation, the transient reactance of the machine is used rather than the synchronous impedance for normal-load operation. The difference in these values is large, but the effect on the total impedance between the rotating masses may or may not be appreciable. In general, for low- to high-voltage systems, most of the impedance is in the system, so the total X is not affected significantly. However, in EHV and UHV systems with very large generating units, the effect is quite significant. In fact, in these systems the electrical center is often within the unit generator transformer or within the generator.

After a system disturbance, the rate of the swing and the voltage–current fluctuations is quite variable. At first the swing angle moves relatively fast, slowing down as the maximum angle is reached. If the system is stable, the swing stops, then slowly changing to decrease the angle, thus oscillating with smaller angular changes until equilibrium is reached.

If the system cannot maintain stability, the angle changes slowly close to 180° , when a pole is slipped and a sudden large angular change occurs. This process is repeated with increasing speed each time a pole is slipped, until the system is separated.

14.5 SYSTEM SWINGS AND PROTECTION

As a rule, the phase–overcurrent relays should not operate on system swings and out-of-step operation. This is because this type of protection is normally applied in the lower-voltage parts of the system, at which the stability limits are seldom as critical, and that these relays are set well above the load current. With the out-of-step currents not too high, the relay-operating times at these low multiples would be long. If the out-of-step condition were permitted to continue, there would be a possibility of the time–overcurrent relays “notching-up” and operating after repeated current peaks. Instantaneous overcurrent relays that are normally set well above maximum load may not operate on an out-of-step system swing.

Stability tends to be more critical in the higher-voltage systems. The reduced voltage and increased current during system swings appear as a

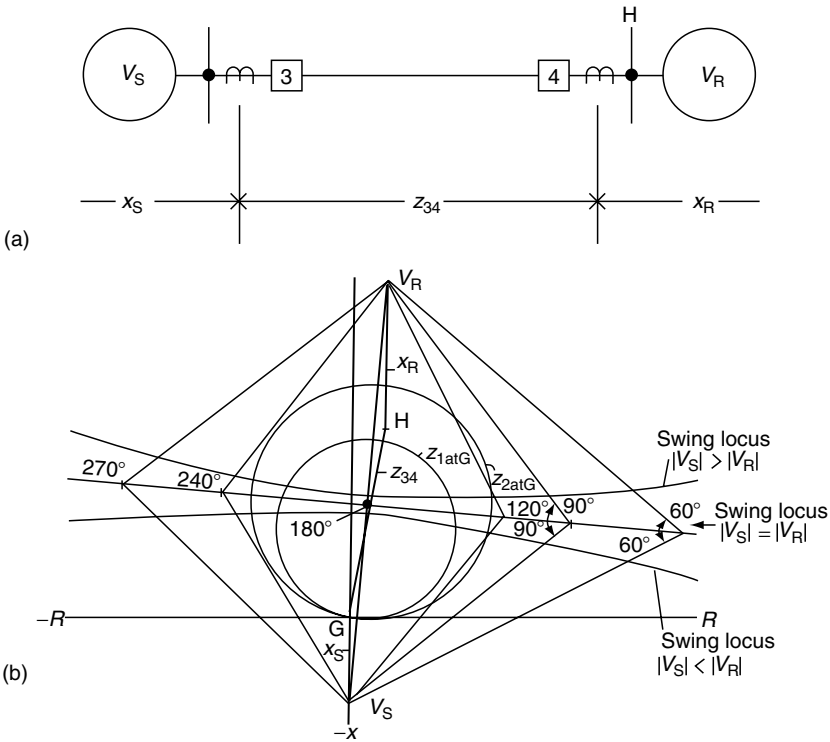

FIGURE 14.3 Typical impedance swing loci for the simplified two-machine system after a fault is cleared: (a) system of Figure 14.1a after line 1–2 is opened to clear fault; (b) typical distance relay settings at 3 bus G and the system-swing loci after faulted line 1–2 is opened.

variable impedance to the distance relays commonly applied for protection. This effect can be illustrated with the simplified two-machine system and the R – X diagram. In Figure 14.3b the total system equivalent impedance after the fault is cleared by opening line 1–2 (see Figure 14.1a), which is plotted between V_S and V_R on the R – X diagram. Arbitrarily, the origin is at a relay location such as 3 at bus G.

The locus of the system swing assuming $|V_S| = |V_R|$ is along a perpendicular line bisecting the line drawn between the V_S and V_R points as shown. On this swing locus, the impedance points at various angles between voltages V_S and V_R are the points of the corresponding angle between lines from points V_S and V_R and the swing locus. Thus, on the $|V_S| = |V_R|$ swing locus, impedance points are plotted for 60° , 90° , 120° , 180° , 240° , and 270° angles that V_R lags V_S . The impedances “seen” by distance relays 3 at bus G and relays 4 at bus H are the phasors from points G and H, respectively, to the

locus line. The change in this impedance is relatively slow and variable, as discussed earlier.

If V_S lags V_R , the normal load is in the second quadrant, rather than the first quadrant, and the swings move from left to right. The actual swing curves are more complex and are arcs of curves that are functions of the difference in the magnitudes of V_S and V_R , system impedance and voltage variables, governor and regulator actions, and so on. The common swing loci for the differences in the two source voltage magnitudes are illustrated in [Figure 14.3b](#). In actual practice, the swing impedance as seen from any given relay may be anywhere in the four quadrants and move in any direction during a swing segment. With the disturbance usually resulting from a fault, there can be a major shift of the impedance seen by the relays as the fault is cleared to change the transfer impedance (as illustrated in [Figure 14.1b](#)) across the system. Computer studies provide more accurate information for specific systems and conditions. This should be used for determining relay operation, settings, and applications.

However, the R - X diagram scenario is similar for all cases. Plotting only a specific line impedance under consideration on the R - X diagram (as the impedance behind each line bus will vary with switching), normal operating conditions (load) should appear as impedances outside the relay operating characteristics. Normally, for the relay at the origin, load into the line is in the first quadrant, load out of the line is in the second quadrant.

When a system disturbance occurs, the impedance changes immediately. If the fault is the disturbance and is within the line under consideration, the impedance seen by the distance relays moves into their operating zone, and the line is tripped. If the disturbance is outside the line under study, the impedance seen instantly shifts to a new location somewhere in the four quadrants. During a fault, there is a small swing period, then another shift as the two line breakers clear the fault. If the breakers do not open simultaneously, the swing will exist during the fault, an instant shift to a new location when one breaker opens, another small swing changes, then an instant shift to yet another location as the second breaker opens. At such a moment, when the fault is cleared, the swing continues, typically as illustrated in [Figure 14.3b](#). For the example of [Figure 14.1](#), the swing is assumed to start, as shown in [Figure 14.3b](#), at about an angle ϕ of 50° , which corresponds to the point 1 angle in [Figure 14.1b](#).

If the system is stable, the impedance locus will move with decreasing speed to about 80° , which corresponds to point m in [Figure 14.1b](#), and where area 1 = area 2. Then the impedance phasor momentarily stops, reverses, and moves out to the right. Eventually, after short oscillations, a new equilibrium is reached at which the system will operate until the next load change or disturbance occurs.

If stability is lost, the impedance phasor will move beyond the 80° point in the example to 180° , where a pole is slipped and the two parts then operate

out of synchronism. The impedance change generally slows down to the 180° point, then moves rapidly to the left and back to the right to pass through the 180° point again, unless the two parts are separated elsewhere. As indicated earlier, generally, systems can swing on a transient basis to near 120° and remain stable.

Thus, distance relays that respond to balanced three-phase conditions and faults will operate when the swing or out-of-step impedance phasor moves into and remains long enough within their operating characteristic. Directional comparison pilot systems using phase distance fault detectors are also subject to operation when a swing phasor impedance moves through their operating zone. Phase comparison, current differential, and other current-based pilot systems are not subject to operation on swings and out-of-step conditions as current flows associated with such conditions are “through” currents, which flow in and out of network lines that make up the associated power system.

The swings shown in [Figure 14.3](#) are typical of the events after a fault has occurred and been cleared. Two examples of the complete scenario from the occurrence of a fault are shown in [Figure 14.4](#) and [Figure 14.5](#). Both plot the impedance changes at a 115 kV relay location in highly interconnected power network that resulted from a fault on a 500 kV transmission line. The system diagram is an abbreviation of a complex network.

For fault 1 (see [Figure 14.4](#)), the impedance seen by the relay before the fault (initial operating point: time 0) is at the far left. Load was flowing from B to A on the 115 kV line. At the instant of the fault, the impedance instantly changes to the right (fault occurs: time 0). In other words, zero time is represented by the broken lines. A swing occurs for 0.067 sec (four cycles) when the near breaker trips with another instant change. Next, the swing continues for 0.083 sec (five cycles) until the far breaker opens. At that moment, the fault is cleared. But the system has been disturbed, hence the continued swinging, as shown by the heavy line from left downward to the right. At the beginning, the swing is fairly rapid, but slows down as it approaches the 180° point, at which a pole is slipped and synchronism is lost. The swing then speeds up and the system would continue to operate out of synchronism, moving faster and faster at a variable rate until a separation is made.

At 0.40 sec, the near breaker was reclosed in an attempt to restore the line to service. This was unsuccessful, the breaker retripped and the swing continued. For fault 2 (see [Figure 14.5](#)), the same events occur; fault occurs near breaker trips in four cycles, near remote breaker trips in five cycles, and system continues to swing slow at first, slowing down and (as illustrated in [Figure 14.5b](#)) stops, turns around, and moves to a new stable operating point. Thus, synchronism is not lost, and the system recovers and continues to operate. The near breaker was reclosed at 0.416 sec (25 cycles), but retripped as shown.

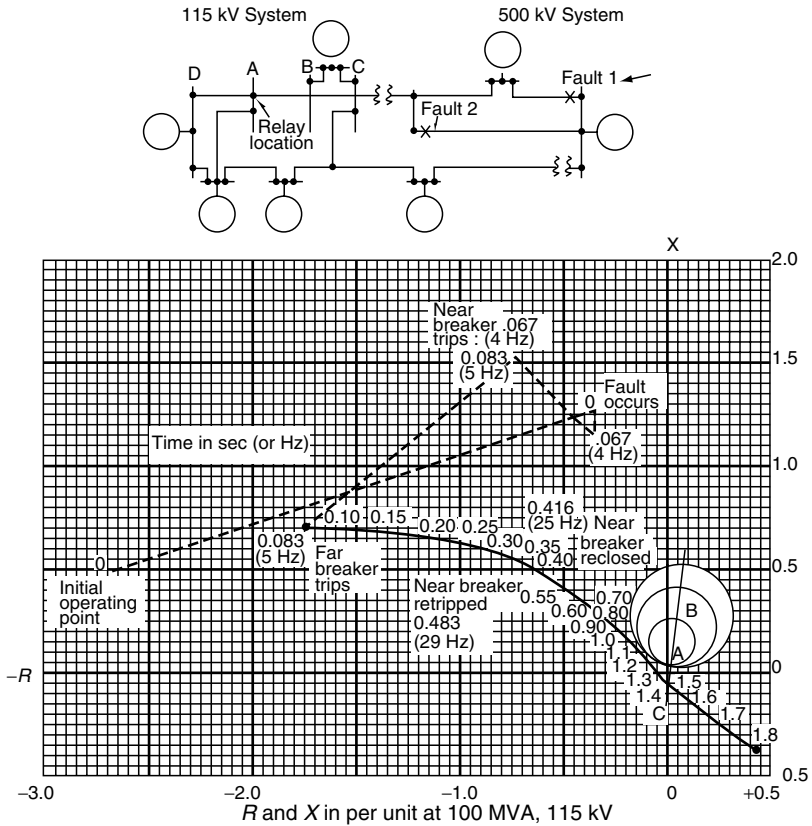

FIGURE 14.4 A 500 kV fault that caused the 115 kV system to lose synchronism.

14.6 OUT-OF-STEP DETECTION BY DISTANCE RELAYS

From the previous discussion, the “handle” for relay detection of out-of-step conditions is the rate of impedance change seen by distance relays. Detection can be accomplished with two distance units, one set for a longer reach and essentially surrounding a unit set with a shorter reach. With this combination, a fault falling within the operating zone will operate both units simultaneously. However, a swing that occurs within their operating zones will first operate the outer or longer-reach set unit and, as it progresses, later operate the inner or shorter-reach set unit. Logic is arranged so that output will occur only for a sequential operation of the two distance units. Ideally, an out-of-step condition is indicated when the time difference between the two distance units’ operation is approximately 60 msec or more, with a typical distance unit setting about 20%–30% apart. The two types most commonly

applied are illustrated in Figure 14.6. These distance relay characteristics were described in Section 6.5 (see Figure 6.13).

The concentric circle application is generally applicable to the shorter lines up to about 100 mi, and where the outer circle Z_{1OS} can be set such that it does not operate on the maximum load impedance phasor. On long and heavily loaded lines, the blinder type generally will be required for line protection as well as swing detection, to provide extended reach for the line with restricted tripping for loads.

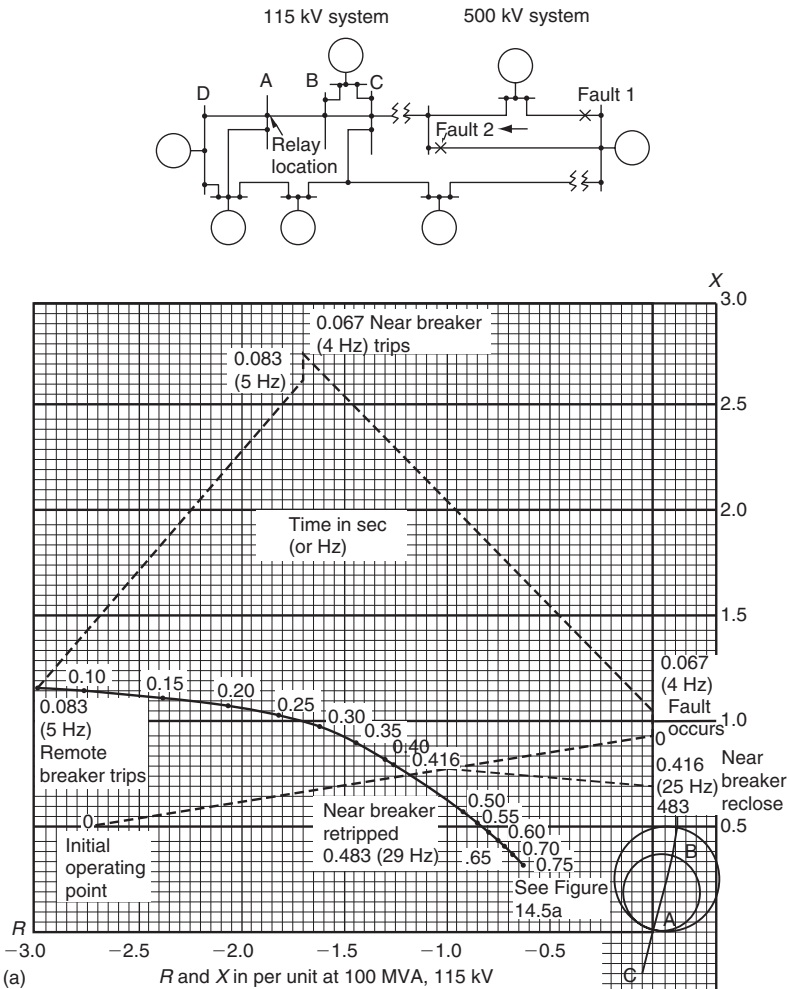

FIGURE 14.5 (a) A 500 kV fault for which the 115 kV system was able to maintain stability. (Continued on next page.)

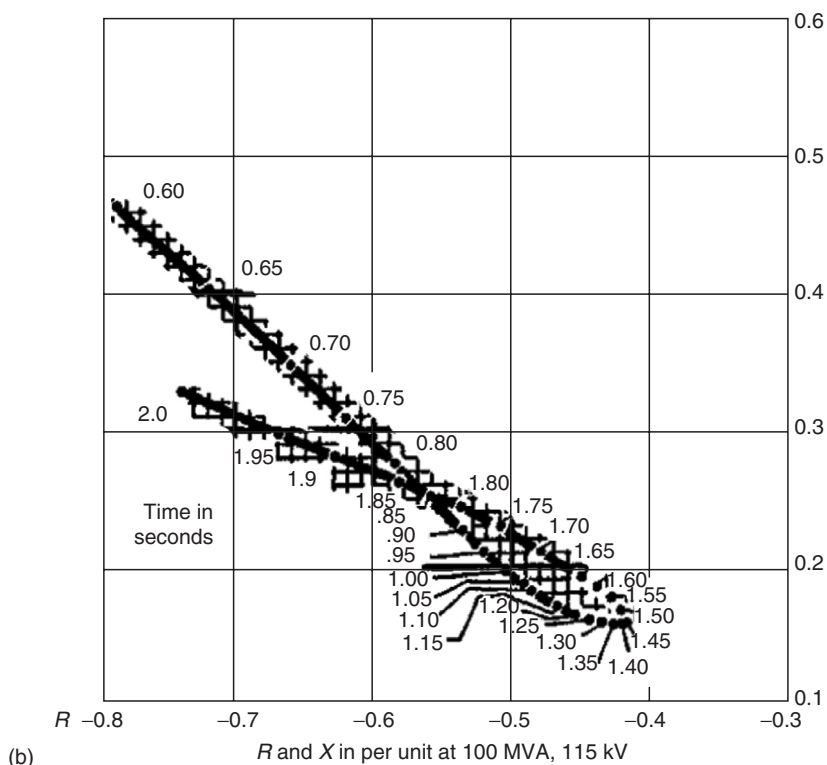

FIGURE 14.5 (continued) (b) Enlarged arcs are shown for the 115 kV system's recovery from the 500 kV fault.

Application of out-of-step relays is complex, depending on system factors, operating practices, and individual protection philosophies. As a result, there is little uniformity among the utilities. However, the basic objectives are the same.

1. Avoid tripping for any disturbance for which the system can recover. Thus, relay operation should not occur for all stable swings. Stability studies can provide the minimum impedance that the relays will notice for stable operation, so that the phase distance relays can be set to avoid operation on these impedance values.
2. For unstable system operation, it is mandatory to separate the system, such that after it goes out-of-step it cannot recover without separation. This separation preferably should be done at a point where (a) the generation-load balance will permit the parts to continue service

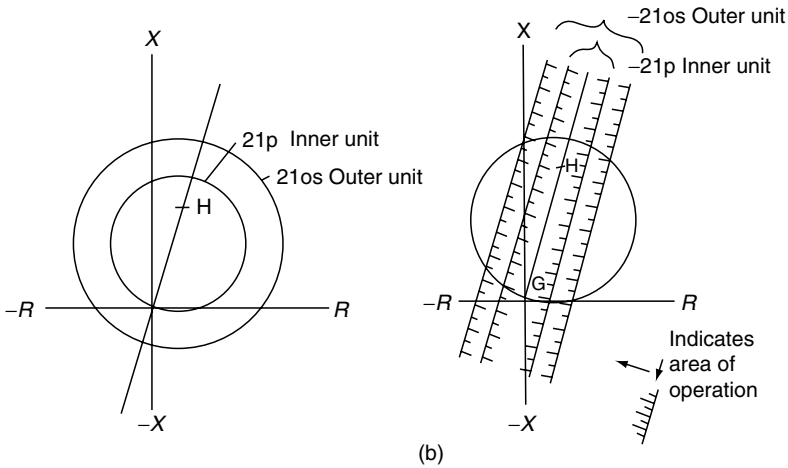

FIGURE 14.6 Typical distance units applied for out-of-step detection. (a) Concentric circle type. (b) Double-blinder type.

temporarily and (b) at a convenient location where the parts can be resynchronized and reconnected. Usually, these objectives will be in conflict to a varying extent depending on the system operating conditions at the time of the disturbance. As a result, considerable compromise and judgment is required; there are no easy answers.

In the past, the general practice was to apply out-of-step blocking in the transmission system. The aim was to keep the system intact to avoid possible long delays after a system disturbance in reconnecting the various lines that may have opened. In practice, it is doubtful that many line circuits would be involved and trip during a system disturbance. Thus, the trend seems to be toward more out-of-step blocking of automatic reclosing after the line relays operate, as reclosing only adds more “shock” to an already disturbed system.

Out-of-step tripping has not been used widely over the years, but is receiving considerably more attention, particularly with very large generator units connecting EHV and UHV networks. The higher generator reactances and lower inertia constants have reduced critical clearing times. Thus, stability limits tend to be more critical and early separation is more important, should the system become unstable.

On the other hand, opening a circuit breaker when the two parts of the system are essentially 180° apart may result in breaker damage. This is because of the high-recovery voltage across the breaker contacts when interrupting near 180° between V_S and V_R . An ANSI standard specifies that out-of-phase switching breakers must be able to interrupt a current 25% of the rated

interrupting current with a recovery voltage of 3.53 pu rated line-to-neutral voltage. Various out-of-step tripping schemes are available to detect out-of-step conditions as the impedance phasor moves into the operating areas, such as shown in Figure 14.6, but to inhibit breaker tripping until the out-of-step swing impedance phasor passes out of the outer unit 21_{OS} . At that time, the angle of V_S and V_R is less than 180° , decreasing to a more favorable angle for breaker interruption.

Specific and additional information on the application and details of available schemes for line and generator out-of-step indication and protection should be obtained from the various manufacturers.

14.7 AUTOMATIC LINE RECLOSING

More or less close to 80%, to as high as 90% of faults on most overhead lines are transient. These result primarily from flashover of the insulators by high-transient voltages induced by lightning, by wind causing the conductors to move together to flashover, or from temporary tree contact, usually by wind. Therefore, by de-energizing the line long enough for the fault source to pass and the fault arc to deionize, service can be restored more expeditiously by automatically reclosing the breaker. This can significantly reduce the outage time, and thus, provide a higher service continuity to customers. However, it is important to recognize that automatic reclosing without checking synchronism should be done only (1) if there are sufficient other interconnections to hold the separated parts in synchronism or (2) if there is a synchronous source at only one terminal, with none at the others.

Reclosing can be one single attempt (one-shot) or several attempts at various time intervals (multiple-shot). The first attempt may be either “instantaneous” or with time delay. Instantaneous here signifies no intentional time delay, during which the circuit breaker closing coil is energized very shortly after the trip coil has been energized by the protective relays. This is accomplished by a high-speed (52 bb) auxiliary switch on the circuit breaker that closes as soon as the breaker mechanism starts moving to open the main interrupting contacts. Thus, both the trip and the close coils are energized together; consequently, the breaker contacts are open for a very short time. The time from energizing the trip coil to the reclosing of the breaker contacts on an instantaneous reclose cycle is a function of the breaker design: typical values are 20–30 cycles. Generally, this is sufficient to permit the fault arc to deionize during the period when the circuit is open. Experience has indicated that in a three-phase circuit, on an average, the de-energized (open or dead) time for the fault arc to deionize and not restrike is

$$t = \frac{\text{kV}}{34.5} + 10.5 \text{ cycles.} \quad (14.4)$$

This formula applies where all three phases are opened and there is no trapped energy, such as from shunt reactors, or induction from parallel lines. For single-pole trip–reclose operation, longer deionizing times are required, because energy coupled from the unopened phases can keep the arc active. The deionizing times can be increased by $\pm 50\%$.

Many varieties of reclosing relays (79) are available with varying degrees of sophistication for single and multiple shots. After their cycle of operation, if reclosures are successful at any point, they reset after a preset time interval. If reclosure is unsuccessful, they move to a lockout position so that no further automatic operation is possible. After service is restored by manual operation of the circuit breaker, the reclosing relays reset after a time delay. This is to prevent an automatic reclose operation if the breaker inadvertently gets closed manually with a fault persisting on the line.

As many stations and substations are unattended and are operated by various remote control systems, the reclosing requirements can be programmed into the automation and controlled from a central dispatch office. A few operations of this type are currently in service. Reclosing practices are quite variable, depending on the type of circuit and individual company philosophies. A brief review will outline more common practices.

14.8 DISTRIBUTION FEEDER RECLOSING

For an overhead radial feeder without synchronous machines or with minimum induction motor load, fast reclosing at the source offers a relative high probability of rapid restoration of service. The almost universal practice for these types of circuits is to use three and occasionally four attempts to restore service before locking out. Subsequent energizing is by manual closing. Generally, the first reclose is instantaneous, the second about 10–20 sec after retrip, the third attempt about 20 to as much as 145 sec after retrip. Specific times vary widely; however, the most current trend has been to keep the third reclosing time in the 10–20 sec range in view of the public safety concerns. When applying four reclosure attempts, the time intervals between them are smaller.

Reclosing is generally not used for underground feeders, because cable faults are more inclined to be permanent. Reclosing is used in practice for combination overhead–underground circuits, with more inclination to use it when the percentage of overhead to underground is high.

For industrial ties with large motor loads or synchronous machines and for ties connecting “cogeneration” sources, care is required that reclosing at the utility substation does not cause damage to the rotating equipment. Generally, the connections are by single-circuit ties, so that during the open period the two parts will be operating independent of each other. Reclosing then will connect the two parts together out of phase, resulting in power surges and large mechanical shaft torques that can cause severe damage.

With synchronous machines, reclosing must be delayed until the machines are removed from the circuit; then reclosing can restore voltage and pick up the static and nonsynchronous loads at the station. This can be accomplished by over- and underfrequency (UF) relays with under- and overvoltage relays. Transfer trip should be used to disconnect islanded machines that can carry load connected to them in the island.

For induction motors, reclosing should not take place until their residual voltage has decreased to 33% of rated value. In general, the induction motor voltage decreases very rapidly, for there is no field to supply excitation. Joint cooperation is very important with these types of interconnections. This subject is discussed in greater detail in [Chapter 8](#).

Where there are multiple fused taps off a distribution feeder, a common application is to apply an instantaneous trip unit set to overreach these fuses out to the first main feeder sectionalizing point. Fast reclosing is then used and, if unsuccessful, further operation of the low-set instantaneous relays is blocked. With the higher percentage of transient faults, this prevents the fuse from operating, should the fault remain on the downside of the fuse, thereby minimizing long delays in fuse replacement. If the fault is permanent, the fuse will clear faults within its operating zone and range. This is known as fuse-saving and this subject is covered in [Section 12.6](#).

14.9 SUBTRANSMISSION AND TRANSMISSION-LINE RECLOSING

Circuits that are used to transfer power between stations require reclosing of both terminals to restore service. This can be done at high speed only if there are sufficient parallel ties in the network to provide an exchange of power between the two parts of the system. This is necessary to hold the source voltages in synchronism and particularly in phase during the line-open period. This reclosing requires high-speed simultaneous tripping of the line and so is limited to circuits protected by pilot protection. If this protection is not used or is out of service, fast reclosing should not be used or should be blocked.

Where the effectiveness of the parallel ties is in doubt, several reclosing possibilities exist:

1. Single-pole pilot trip and reclose, described in [Chapter 13](#).
2. With pilot relay protection for simultaneous line tripping, reclose one end instantaneously and the other end after a check to ensure that the line and bus voltages are synchronous and within a preset angle difference. Synchroverifier (25) relays operate when the “beat” frequency across an open breaker is within prescribed limits, the two voltages on either side are of sufficient magnitude, and the angle between them within a preset value. The usual angle adjustments are about 20°–60°.

3. Without pilot protection, or when preferred, reclose with (a) live line, dead bus; (b) dead line, live bus, or (c) live line, live bus with synchrocheck. It is desirable to operate these through reclosing relays to avoid potential breaker “pumping.”

Different combinations for reclosing are applicable and depend on the operating and system requirements.

On the one hand successful reclosing of both terminals of a line increases area 2 availability (see Figure 14.1b) by moving from the “breaker 1 and 2 open” curve to the higher “all lines in service” curve shortly after point 1. This aids stability. On the other hand, if reclosing is not successful, such as for a permanent fault, area 1 is increased by the additional fault and retrip time operation along the low “line-fault” curve. Area 2 is also reduced, so that the stability limit is reduced, because $area\ 2 = area\ 1$ at a very low angle θ .

However, because most line faults are transient and the stability limit is frequently never reached, simultaneous instantaneous reclosing is widely used for lines of 115 kV and up. Generally, only one attempt is made, but occasionally subsequent attempt(s) are made with the voltage check or synchrocheck equipment outlined earlier. However, this is only for overhead lines. Transmission cable circuits are not reclosed. For overhead-cable combinations, separate protection is sometimes used for the cable and overhead section, with reclosing permitted for the overhead line faults only.

Questions have been raised about the application of instantaneous reclosing at or near large generating stations. This is because of the potential damage to the long turbine shafts of large modern turbine generator units. An example is a solid or near-solid three-phase fault near or at a generator bus. This reduces the voltage of the three phases to zero, so that no power can be transferred until the fault is cleared. Even with very fast relaying and circuit breakers, the voltages on the two sides of the breaker are at a different angle, so reclosing results in a sudden shock and movement of the rotor and to transient oscillations and stresses. These are cumulative; hence, actual known damage may occur at some time in the future. Experience has not documented any large amount of damage, but this remains a potential worry. Some utilities are removing the reclosing near large generator stations; others are not. The issue is a very difficult one, and is one that is not easily resolved. It is further complicated because the most severe types of faults (three-phase- and two-phase-to-ground) occur rather rarely. Thus, perhaps the cumulation of stresses will not exceed a critical damage point during the equipment lifetime. In the meantime, more benefits of reclosing are obtained.

This raises another difficult question: how far apart can the voltages remain before damage and problems with stable operation occur? Out in the system, voltage differences on the order of 60° or more have existed before reclosing, and reclosing has been successful. Here the system impedance network can absorb this large difference. This would not be tolerated

near a generating unit. It has not been possible to provide general limits, as each application depends on the specific system.

Reclosing on multiterminal lines is more complex, especially if more than two terminals have synchronous voltage sources. It may be practical to reclose one or two terminals instantaneously and the others after voltage or synchrocheck. Where the transmission line has load taps, such that it serves the dual function of transmission and distribution, circuit reclosing of the source terminals can facilitate service to the tap loads as long as no synchronous equipment is involved. In these circumstances, the requirements outlined earlier under distribution feeder reclosing are also applicable.

14.10 RECLOSING ON LINES WITH TRANSFORMERS OR REACTORS

Lines that terminate in a transformer bank without a breaker between them, or lines with shunt reactors, should not be reclosed automatically unless it can be assured that the fault is in the line section. Differential or transformer reactor protection can be used to block reclosing at the local station, with transfer trip to block the remote station. This generally means some delay in reclosing to ensure that the trouble is not in the transformer or reactor. If the line protection excludes the transformer bank, this protection can only initiate reclosing. Breakers are not generally used with shunt reactors, so the protection zone for the line would include the reactors.

Transformers are sometimes connected to a line through a motor-operated air-break switch. For faults in the transformer, the protection trips the low-side transformer breaker, initiates a remote trip by a grounding switch or transfer trip channel, and opens the air switch. Reclosing of the remote terminal(s) may be initiated after coordinating time delay for the air switch to operate. This may be supervised only on receiving the remote trip signal.

14.11 AUTOMATIC SYNCHRONIZING

This equipment can be applied for automatic synchronizing at attended or unattended stations, or to assist manual synchronization. It does not adjust the two separated systems, but will program closing as the voltages arrive in phase when the frequency difference is small. The synchroverifier type is not recommended for this service, but has been used for small machines about 500 kVA.

14.12 FREQUENCY RELAYING FOR LOAD SHEDDING—LOAD SAVING

The primary application of underfrequency relays is to detect overload. Load shedding or load saving is the attempt to match load to the available

generation after a disturbance that has left a deficiency in the generation relative to the connected loads. Thus, the overloaded system or part of a system (island) begins a frequency decay that, if not halted, can result in a total system shutdown, for example, the situation that was experienced in the 1965 Northeast blackout. Generating plants generally cannot operate below 56–58 Hz (60 Hz base).

Normal load changes and moderate overloads can be absorbed by the spinning reserve in the system—power systems are specifically operated such that all the generators are not operating at full capacity. Owners of such generators are typically paid for generation maintained in reserve. Thus, these overloads result in small increments of reduced speed and frequency that activate the governors to increase the prime-mover input. As has been outlined earlier, transient changes, such as those that result from faults, involve the exchange of kinetic energy of the rotating masses to the system until the system can readjust to a new equilibrium.

When the load requirements significantly exceed the generation capabilities, the frequency of the system decreases. The power system can survive only if enough load is dropped until the generator outputs are equal or greater than those of the connected loads. This imbalance most often results from the loss of a key or major transmission line(s) or transformer(s) that are involved in a major transfer of power, either within the system or between two interconnected systems. Power systems are designed and operated such that a single failure should not lead to an underfrequency condition. Power systems are most vulnerable to overload conditions during high load periods or multiple outages of key system facilities. Multiple outages often occur during storms or other unusual conditions. The blackouts that occurred in the western part of the United States in the late 1990s were initiated when lines became heavily loaded and faulted when they sagged into trees. The heavy loads were caused by extremely hot weather conditions and unusual load flow patterns. The chain reaction of line trips resulted in portions of the power system separating into islands. When islands are formed within a power system, high probability exists for a mismatch of generation and load to exist within the island. If excess generation exists, frequency will increase and generation will run back in an attempt to create a suitable balance. If load exceeds generation, frequency will drop and load needs to be shed to create an acceptable balance. The rate of frequency decay in such situations is, in general, relatively fast. The rate at which the frequency drops is a variable function with time, depending on the amount of overload, the system inertia constant, and the load and generation variations as the frequency changes. This subject is covered in detail in the articles by Dalziel and Steinbach as well as Berry et al. In any event, in general, a significant decay in frequency usually occurs within a few seconds. This period is too short to rely on operator action for shedding load, and, therefore, automatic underfrequency load shedding facilities need to be provided to initiate the required load

shedding action. Details of the design of underfrequency load shedding schemes as discussed in the next section are based on the generalities that follow:

The handle to detect overloads on portions of power systems is underfrequency or the rate of frequency decline. In a large system, there can be an almost infinite number of possibilities that can result in load-generator imbalance, so it becomes difficult to determine quickly and accurately where and what action should be taken. The present practices are to apply under-frequency relays at various load points set to progressively remove load blocks until the frequency decay is stopped and returns to normal. Generally, underfrequency is used, but rate of change of frequency has some use.

Any measurement at one point in the system, as with underfrequency or rate-of-change relays, is an approximation of the problem. As a result, generally, more load is probably shed than may actually be necessary, but it is far more important to avoid a massive shutdown.

It is desirable to locate the relays on a distributed basis throughout the system. They are set at different frequency levels to trip varying amounts of load. General practice has been to use three frequency steps between nearly 59.7 and 58.3 (60 Hz normal), although as many as five steps have been applied. As far as possible, nonessential loads are removed first, sometimes with rotation among different loads.

The early frequency relays (81) were electromechanical, with present relays of the digital type. The latter operate by counting the zero crossings of the filtered AC system voltage, and are extremely accurate.

Frequency relays can be used to restore or supervise the restoration of load after the system is stabilized and generation capability is available to meet the dropped load. If load restoration is done automatically, the loads should be added in small increments, with sufficient time intervals for the system to adjust, to avoid reversing to reduced frequency.

The application and setting of underfrequency relays is not standardized and, for the large systems, is based on a study of the most probable and worst-case possibilities, seasoned with general experience and judgment. For interconnected systems, such as those that exist in U.S. power pools, it is important that a common pool program be developed and implemented through the interconnected systems. This can involve separating the system when a heavy power interchange occurs that is unfavorable to an undisturbed system.

The present wide use of load shedding has both prevented blackouts and limited some to small areas with minimum outage times. However, not all possibilities can be anticipated, so blackouts will continue to occur, one hopes quite limited, and for very short outage times.

Ultimately, perhaps, multiple measurements across the system can be sent to a central location for programmed analysis of the problem, with solutions

quickly dispatched to the proper locations for rapid matching of load and available generation. It appears that this will involve considerable data and communication facilities operating at high speeds.

14.13 UNDERFREQUENCY LOAD SHEDDING DESIGN

There are several aspects involved in the design of underfrequency load shedding schemes. One aspect involves the design of an underfrequency load shedding criterion. A load shedding criterion involves the selection of the amount of load to be shed, the number of steps in which load is shed, and the frequency set point for each step. A second aspect, scheme architecture, involves the locations at which frequency is detected and the manner breakers are tripped to drop load. A third aspect, underfrequency control design, relates to the actual design of the underfrequency relay control circuits.

14.13.1 UNDERFREQUENCY LOAD SHEDDING CRITERIA

The criteria for underfrequency load shedding systems in the United States are normally dictated by standards developed by reliability councils, independent system operating organizations, and power pools. The amount of load shed varies between 25% and 50% of the total load and is shed in three to five frequency steps. The frequency band between the load that is shed falls within 59.7 and 58.3 Hz.

The amount of load to be shed within a load area is determined by studies that approximate the amount of generation deficiency that the area would be subject to following a severe disturbance. A typical disturbance might involve the loss of import capability to the area because of loss of inter-area ties along with the outage of the largest generator internal to the associated load area during peak load conditions. The range of frequency levels at which load is shed is selected based on the following criteria:

1. Operation of the load shedding scheme must be immune to operating on normal transient frequency dips from which the power system is capable of recovery without the need for dropping load.
2. During overload conditions, load shedding must occur before the operation of underfrequency relays that are applied for generator protection. Load must be shed before the generators are tripped.

High-speed operation of underfrequency relays is required, considering the rapid rate of frequency decay that is possible during overload conditions. A small time delay is required, however, to prevent operation on transients. Operating times of underfrequency relays ideally range between 5 and 20 cycles. A number of steps are used in load shedding schemes to attempt to facilitate a match between generation and load within the overloaded area.

If the entire block of load was dropped in one step, stabilization of the area could probably be hampered by excess generation.

Underfrequency load shedding criteria often include restrictions such that feeders that supply critical load such as hospitals, airports, iron lung patients, etc. are not tripped by underfrequency relays. In addition, as described in [Chapter 8](#), distributed generation is normally tripped by underfrequency relays that are set to operate quickly to trip the generator if it becomes isolated with a portion of the power system. The settings of the underfrequency relays at the intertie location of distributed generation are often set such that they are subject to operate before the load shedding underfrequency relays occur. When this is the case, additional load should be placed under control of underfrequency load shedding relays to account for the amount of distributed generation that may be tripped during an overload condition.

14.13.2 UNDERFREQUENCY LOAD SHEDDING SCHEME ARCHITECTURE

Load is typically shed by opening breakers that terminate radial lines at distribution substations. The architecture of load shedding schemes can be local, distributed, or centralized.

1. Local load shedding is the most common design that had been used in the past. In such schemes, one or more underfrequency relays are installed on buses at distribution substations. Upon operation of the underfrequency relay(s), feeder breakers are tripped based on logic incorporated into the circuitry at the substation. Decisions involving load shedding are all made locally at each associated distribution substation.
2. Distributed load shedding schemes are similar to local schemes in that decisions for tripping breakers are made locally at the individual substations. In distributed systems, however, each feeder is equipped with its own underfrequency relay. Such schemes have grown in popularity with the availability of microprocessor-based relays that, in addition to providing normal line protection functions, often contain an underfrequency function at minimal additional cost.
3. Centralized underfrequency load shedding schemes are similar to local schemes in that one or more underfrequency relays are connected to buses at distribution substations. In centralized systems, however, the underfrequency relay output information is sent to a centralized location to be processed in a computer program, which is applied to provide overall load shedding control. Information is then sent back to the distribution stations for tripping breakers as selected by the computer control program.

An advantage of a local system is that a communication system is not required to send information to a remote location. Communication systems are costly,

add time delay, and increase probability for error. Local systems, however, require considerable additional wiring at the substation. Distributed systems require minimal additional wiring, are low in cost, and allow using of the flexibility inherent in microprocessor relay designs. Such systems, however, can be difficult to implement in stations that already possess a local system without a complete changeout of the local system. Centralized systems offer greatest flexibility for adjusting the underfrequency logic to best meet the needs of the specifics of the disturbance encountered. As a picture of the conditions over the entire system is available at the centralized location, better decisions can be made with regard to location and magnitude of load to be shed.

14.13.3 UNDERFREQUENCY CONTROL SCHEME DESIGN

The design of underfrequency control schemes involves the operating principle on which underfrequency is detected, type of underfrequency relay used, and the arrangement of logic in the control circuit.

Underfrequency relays operate on a fixed frequency or rate of change of frequency principle. The majority of underfrequency load shedding systems that are in service operate on a fixed frequency basis. Fixed frequency relays function on the basis that operation of the relay occurs whenever frequency drops below a fixed frequency setting on the relay. Fixed frequency underfrequency relays are designed to operate very fast (six cycles or less). One disadvantage of using fixed frequency relays in underfrequency load shedding schemes is that frequency must be low before operation occurs. As such, load may be shed too slowly to arrest overload conditions in which frequency drops at a high rate.

To improve performance of underfrequency load shedding systems, application of relays that are capable of operating on the rate of change of frequency has been proposed. The rate of change of frequency is an immediate indicator of power imbalance. The use of such relays therefore may provide for a more robust load shedding system in that load may be shed in a more timely manner based on the severity of the overload condition. The oscillating nature of frequency decay rates, however, can cause such relays to operate incorrectly. In addition, settings for such relays are difficult to determine. At this time, because of these application difficulties, the use of underfrequency relays that operate on the rate of change of frequency is limited.

The types of relays used for underfrequency detection include electromechanical, solid state, and digital. The original underfrequency load shedding schemes that were placed in service in the late 1960s used electromechanical underfrequency relays. Almost all systems placed in service in current times use microprocessor-based digital underfrequency relays. Digital relays have proven to be accurate, reliable, and highly flexible in application.

Underfrequency load shedding schemes must be designed for high reliability. Security is especially important in such designs, as an incorrect operation will result in an outage to a significant amount of load. False operation of underfrequency relays can result from feedback from rotational load. When the source of power to a distribution substation is interrupted, inertia of motor load that had been supplied from the station can cause a gradual, rather than immediate, drop in frequency at the station bus to which underfrequency relays are connected. Under such conditions, underfrequency relays may operate incorrectly and trip the associated feeder breakers unnecessarily. Load supplied by the tripped feeders would, therefore, remain out of service when power to the substation is restored. To prevent such incorrect operations, tripping by underfrequency relay action is supervised by undervoltage relays. Tripping is blocked when voltage drops below the setting on the undervoltage relay. A much lower voltage will exist during a motor feedback condition than during an overload condition. Thus, voltage can be measured to distinguish between such conditions. For additional security, overcurrent supervision can also be applied in the underfrequency tripping circuit. During a system overload condition, load current will continue to exist at distribution substations in the overloaded area. When power is lost to such a substation, however, current flow at the substation will stop as soon as the source power is lost. Current flow at the substation can therefore provide a positive means to distinguish between overload and motor feedback conditions. A typical design for a local underfrequency relay scheme is illustrated in Figure 14.7.

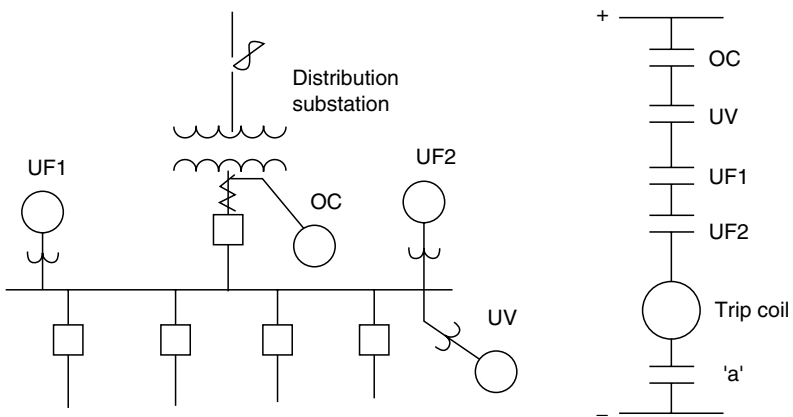

FIGURE 14.7 Typical relay connections and control logic for a local underfrequency load shedding scheme.

Although a discreet undervoltage element is illustrated, this function is often built into the underfrequency relay. Frequency settings for the underfrequency relays are determined by the overall load shedding criterion that has been established. Time delays applied to the underfrequency relays are usually set at six cycles or less, unless specific security concerns exist that dictate the application of a higher time delay setting. Underfrequency rate of change relays are sometimes applied to supplement the fixed setting underfrequency relays are the fixed setting time delays are considered too long to provide satisfactory performance for more severe overload conditions. Undervoltage relays that supervise underfrequency tripping are usually set at about 80% of nominal voltage. Current relays applied to supervise tripping by underfrequency relaying are set to pick up at a current value that is safely below the minimum load at the location that current is measured.

14.14 PERFORMANCE OF UNDERFREQUENCY LOAD SHEDDING SCHEMES

Utilities had experienced operational problems with underfrequency load shedding schemes after such schemes had been initially applied. Feedback from rotational load and drifting of the set points of some of the early underfrequency relay designs were common causes of incorrect operations. The previously discussed security enhancements that have been applied and the development of more reliable relay designs have addressed many of the problem areas that had been experienced.

It should be recognized that underfrequency load shedding systems represent a “last-resort” protection against system collapse. Application of such schemes is not an exact science because the nature of major disturbances is difficult to predict. The manner in which most systems can become generation deficient or separated are numerous. As a result, the effectiveness of load shedding systems can vary considerably depending on the specific characteristics of each individual disturbance. The ideal amount of load that should be placed under underfrequency control is also a general estimate. Events that require operation of underfrequency relays do not occur on a regular basis so “learning through experience” is a slow process. In spite of these obstacles, underfrequency load shedding has functioned effectively in many cases and saved power systems from total collapse. The most promising prospects for improvement of underfrequency load shedding systems is the application of centralized logic with information available from wide area communication systems. Technology for such systems is currently available; however, implementation requires additional incentives as the cost for such systems is high. Utilities are reluctant to commit to expensive projects unless benefits can be quantified sufficiently enough to justify the expenditure. As noted, events that require underfrequency load shedding schemes to function are rare and the probability of their occurrence is difficult to predict. It is

expected that, as power systems are loaded more closely to limits, and networks of digital communication systems become more readily available, it will become easier to justify the application of wide area underfrequency load shedding systems with centralized intelligence.

14.15 FREQUENCY RELAYING FOR INDUSTRIAL SYSTEMS

In general, one underfrequency step is sufficient for the industrial ties that have local generation. The relays would trip loads on the loss of the utility supply, so that the remaining loads match the local generation capability. In this manner, the most essential load for the plant can be maintained. The very rapid decline of the frequency when the loads are large relative to the local generation probably makes more than one step of underfrequency relaying impossible.

It may be desirable to supervise plant load shedding with an undercurrent relay in the utility tie. This would prevent a utility frequency disturbance from necessarily shedding plant load as long as the tie is closed and the utility is able to restore frequency by shedding other, low-priority loads. The undercurrent relay operates to permit local load shedding only when the tie current (or power) is below a set value. A reverse power relay to measure power flowing from the plant to the utility may be necessary to prevent the local generator from supplying power to other loads connected on the same feeder when the utility substation breaker is open.

14.16 VOLTAGE COLLAPSE

Another challenge for a continued operation of power systems is a collapse in system voltage. As system voltage declines, higher currents are required to support power transfer requirements. Such a condition can evolve into a continued spiraling decline in voltage levels across the system to the point of total collapse. Recent trends toward higher power transfers and operation of transmission systems closer to their limitations has resulted in a growing number of events in which widespread degradation of voltages across a power system has been experienced. The consequences of voltage collapse usually results in long and widespread system outages. Schemes applied to prevent voltage collapse must be capable of detecting symptoms of impending collapse in sufficient time to initiate appropriate corrective action. Voltage problems can be caused by facility outages that result from faults or load fluctuations. Degrading voltages over a period of time along with a lack of reactive reserves are indicators of impending voltage collapse. Low reactive reserves are indicated by tie lines operating near the capacity, high VAR loadings on generators, and initiation of reactive power limiters.

14.17 VOLTAGE COLLAPSE MITIGATING TECHNIQUES

The first defense against prevention of voltage collapse is adequate design for providing system reactive requirements. In addition to the need for providing an adequate amount of reactive supply, control systems that can switch such facilities into service within a time frame that satisfies the dynamic characteristics of the power system are required. This involves the application of control systems such as fast-acting automatic voltage regulators, automatic controls for quickly switching capacitor banks, and high-speed reclosing on transmission lines. It is also important for limiters and excitation control systems to be properly set and coordinated such that the full reactive capability of generators is available for system voltage support during degrading voltage conditions.

Reducing load is another means to provide support for system voltage. System load can be reduced without shedding load by reducing voltage levels at the distribution substation buses. Such action could effectively help support voltage levels on the higher-voltage system and can serve to mitigate a slower-acting voltage collapse condition. Voltage reductions on the distribution system can be implemented by system operators. Many power systems have controls available for manual implementation of such reduction to facilitate system operations when system loads approach operating limits. Distribution voltage levels can also be contained by blocking action of automatic transformer tap changers at distribution substations. During normal operating conditions, tap changers would act to raise voltage when the distribution voltage level drops below prescribed values. During degrading system voltage conditions, such actions to increase distribution voltage levels could aggravate the low-voltage problem on the high-voltage system. Tap changers can be blocked manually or automatically when collapsing voltage conditions are recognized.

Recently, load shedding programs to prevent voltage collapse are applied on a more common basis. Shedding load to mitigate voltage collapse should be implemented only after all other efforts to avoid a total voltage collapse have been exhausted. Manual load shedding programs can be effective in stabilizing a gradually collapsing system voltage. In such cases, pre-planned guidelines and procedures are developed for system operators to initiate load dropping when a voltage collapse is evolving. The difficulty with a manual system is that the burden is placed on human judgment to recognize the problem that exists and to determine that the only recourse is to drop load. Actions of system operators are often second-guessed and, as such, operators are often reluctant to shed load if any possibility exists for recovery to occur otherwise.

In some cases, the time frame for voltage collapse can be very short. Such conditions are usually initiated by the sudden loss of critical system facilities. To prevent total collapse under such conditions, automatic load shedding

schemes can be applied. Undervoltage relays are used to initiate load shedding. To provide security for such schemes, several relays are used to monitor multiple phase voltages, adequate time delays are applied to coordinate with normal expected transient voltage variations, and the scheme is supervised by fault detecting relays to prevent operation during or subsequent to system faults. Developing settings for undervoltage load shedding schemes is a complex process that requires a thorough analysis of the dynamic characteristics of the associated power system. The undervoltage relays are generally set in a range of 85%–95% of normal voltage. The applied time delays usually range between 30 cycles and several minutes.

Application of, and experience with, undervoltage load shedding systems are considerably lesser than that for underfrequency load shedding systems. The process leading to undervoltage conditions is complex and requires considerable analysis to properly apply a related load shedding system. Voltage levels across the system, unlike frequency, are expected to drop in a nonuniform manner. Critical buses must be identified at which voltages should be sensed for application in undervoltage load shedding systems. Accurate voltage relays also need to be used because settings are usually near nominal voltage levels. Over time, it is probable that the use of such systems will become more common as a better understanding of the voltage collapse phenomenon is gained and more sophisticated control systems are developed.

14.18 PROTECTION AND CONTROL TRIP CIRCUITS

Trip circuits are a small part of the control circuitry that exists within a substation, which provides functionality for protection, control, metering, and monitoring. Reliable design of trip circuits is of special importance, however, because these circuits directly influence overall protection reliability.

Protection and control circuitry within a substation can represent a complex arrangement of wiring that requires considerable effort and care to create, construct, and test. Even after careful layout and testing, wiring problems are often not discovered until misoperations occur during actual operating conditions. The complex nature of the circuitry sometimes allows for “sneak” circuits to exist, which are difficult to detect. Testing of the entire control system is difficult because of the extensive area covered by the wiring, interrelationships between different portions of the circuitry, and the fact that some facilities may be in service when tests are being carried out. Modern designs are available that significantly reduce the amount of control wiring required through the use of digital communications over fiber-optic cable along with the use of multifunctional digital relays.

The portions of substation control circuitry that allow a path for current flow through the trip coils of circuit breakers are classified as trip circuits.

The facilities that are associated with trip circuits include DC supply systems, relay output contacts, targeting coils, seal-in devices, auxiliary relays, breaker trip coils, various types of auxiliary switches located within associated breakers, and all the wiring that interconnect these devices. Even in modern substation designs that use digital communication systems, trip circuits consist of hardwire design as a DC current is required to be delivered to the breaker trip coil.

14.19 SUBSTATION DC SYSTEMS

The function of a substation DC system is to provide a reliable source of power for protection and control functions at the station. The DC supply is provided by one or more banks of storage batteries, a battery charger, and a DC distribution panel. A stored energy source of power is required for this function as auxiliary AC power at the substation may not be available during faults. It is exactly during such conditions that power is required to power protective devices and to initiate breaker trippings.

Ideal operating voltages of DC systems are 48, 125, and 250 V. The major loads connected to the DC system are the trip and close coils of circuit breakers, power supplies of electronic relays, meters, and communication equipment, along with a variety of auxiliary relay coils. DC systems must be designed to provide the power required by the connected load, a level of redundancy that matches those of the overall protective system, and allow for the ability for performing periodic maintenance and testing.

DC circuits that terminate at the distribution panel are protected with molded case circuit breakers or fuses. The design arrangement of the DC circuits varies depending on the preference of the utility. In one design, a dedicated DC feeder is provided for each breaker and its associated relaying. A more economical design that is commonly used is a tapped-feeder arrangement. In such a design, a DC feeder is tapped for supply to a circuit breaker trip coil. The individual tapped circuits are usually fused. When a breaker is equipped with dual trip coils, each coil is supplied from a different tapped circuit. Tapped circuits that supply a breaker trip coil may also be used to supply relaying associated with the breaker. It is common practice, however, to use separate circuits to supply primary, backup, and breaker failure relaying. Some utilities prefer not to fuse the tapped DC feeders if the loss of the main DC circuit would not reduce reliability of protection beyond desired levels. [Figure 14.8](#) illustrates a possible arrangement for a fused tapped-feeder DC system.

Regardless of what arrangement is used for the DC system, a major design objective is that the system should incorporate a similar level of reliability that is provided for overall system protection. In some cases, although redundant relaying systems are provided, only a single battery bank is used.

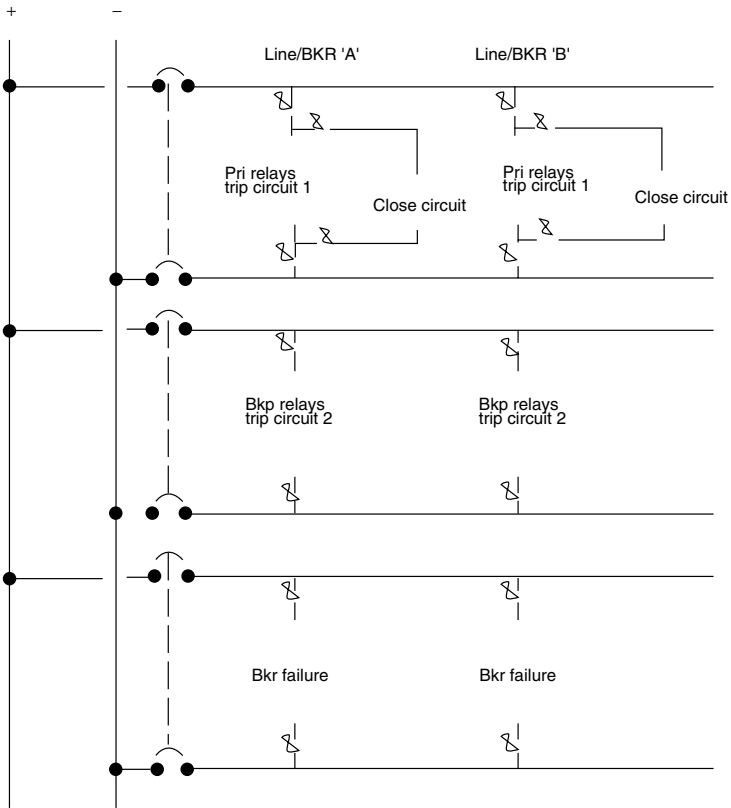

FIGURE 14.8 Typical arrangement of a DC supply using feeders tapped through a fuse.

This practice is based on the relatively high cost of battery systems and the very high level of reliability that experience has shown can be obtained from battery banks when good maintenance and monitoring practices are employed.

14.20 TRIP CIRCUIT DEVICES

Various devices are connected to tripping control circuits that serve to protect other elements in the circuit or to provide logic and initiate actions required for the circuit to deliver its desired functions. Such devices include auxiliary relays, surge protectors, target and seal-in devices, breaker trip coils, and switches.

14.20.1 AUXILIARY RELAYS

Auxiliary relays are used in control circuits to initiate closings or openings in other paths of the control circuitry. For example, in trip circuits, operation of a protective relay often initiates operation of an auxiliary relay, which, in turn, allows a path to be created that allows DC current to flow through a trip coil. Construction of auxiliary relays may be electromechanical or static. Electromechanical auxiliary relays usually take considerable time to operate, which must be taken into account when applied. Time delays for electromechanical auxiliary relays can vary from about 0.25 to 2.0 cycles. Static auxiliary tripping relays usually incorporate an SCR in the tripping circuit along with hand reset mechanical targets, target lamps, and telephone-type auxiliary relays for initiating other required logic.

Lockout relay is a special type of auxiliary relay that is basically a two-position switch with multiple contacts. When a lockout relay operates, it remains in the operate position until it is intentionally reset manually by a handle provided on the front of the relay or by an electrical signal that may be manually or automatically initiated.

In digital control systems that use programmable controllers and digital communication systems, the function of auxiliary relays can be incorporated into the associated control software.

14.20.2 TARGETING AND SEAL-IN DEVICES

Most protective relays incorporate a targeting feature that provides indication at the relay location that the relay had operated to trip the related circuit breaker(s). Targets provide valuable information for analyzing the nature of the tripping event. However, the target must be reset manually at the relay location although targets on modern microprocessor relays may be capable of being reset from a remote location through a digital communication channel. A common method of providing targeting is to use the DC current flowing through the relay to the trip coil to initiate action that causes a target to indicate. The action may be mechanical, electromechanical, or electronic in nature. The target indicator may be a flag, LED, or some other form of electronic indication. In some digital relays, target initiation may be generated internally in software.

A seal-in device is a contact that bypasses the output contact of a protective relay. Action to close the seal-in contact is usually initiated by trip current flow. Sometimes the same coil that allows a target to indicate also closes the seal-in contact. The seal-in contact is not allowed to dropout until the associated breaker(s) that has been tripped is open and trip current has been interrupted by breaker auxiliary contacts. A typical seal-in coil connection is shown in [Figure 14.9](#).

The purpose of the seal-in contact is to protect the relay contact from damage if it should attempt to interrupt the DC trip currents. The relay

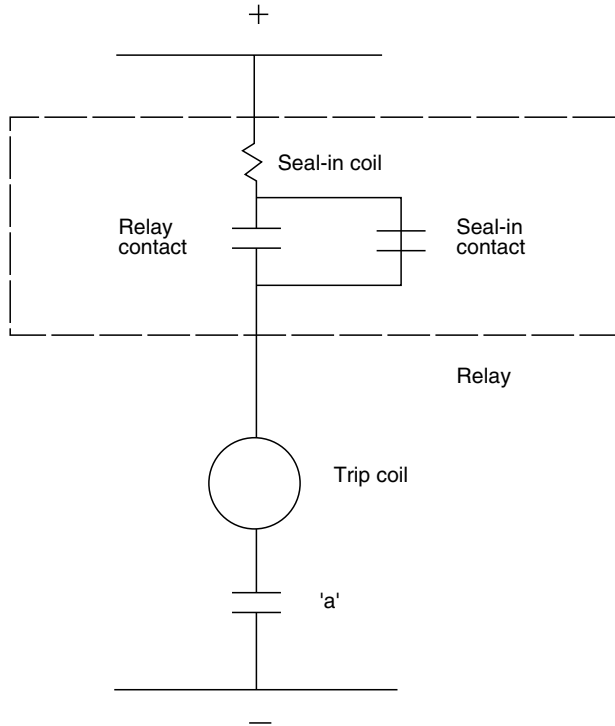

FIGURE 14.9 Trip circuit illustration showing connection of seal-in coil and associated contacts.

contacts are delicate and are not designed to interrupt the DC trip current. The seal-in contact also keeps closure of the trip circuit intact in the event of the relay contacts chattering.

Target and seal-in coils are rated to match the characteristics of the DC system into which they are connected. On electromechanical relays, the target/seal-in coil pickup current is possible to be set as per the requirements. Typical setting values are 0.2, 0.6, and 2.0 A. The highest tap setting should be selected for which positive operation will occur at the DC current that will flow when the protective relay contacts close. Target/seal-in coils are generally located inside the relay and are provided as a part of the relay.

14.20.3 SWITCHES AND DIODES

Manually operated switches may be connected into trip circuits. Such switches are installed to cut out relays, contacts, or portions of the trip circuit to facilitate testing or to remove a relay from service subsequent to a

misoperation. Design practices with regard to the use of switches in trip circuits vary among utilities. The advantage of such switches is that they can make testing more safe and efficient. The disadvantage is that if such switches are left in the improper position, protection may not be available when needed.

Diodes are used in trip circuits to provide the ability for DC current to flow in one direction through a portion of the circuit. Diodes can facilitate providing logic into the circuits that would otherwise require the use of auxiliary relays. The use of diodes reduces cost and complexity of the circuitry. The disadvantage of using diodes is that they are subject to failure, which can remain undetected until a misoperation occurs.

14.20.4 TRIP COILS

The function of trip coils is to initiate action to open the main contacts of breakers. The actual energy to open the contacts is provided by some form of stored energy such as springs, compressed air, and high-pressure gas. Trip coils therefore do not directly open the contacts, but act to release a latch or open a valve that allows the release of some form of stored energy used to move the contacts. Breaker designs can vary considerably among manufacturers and it is important for protection engineers to understand the characteristics of the trip coils and other control devices used in the specific breaker that is used, so that proper trip circuit designs can be developed.

14.21 TRIP CIRCUIT DESIGN

Trip circuits may be required to trip a single breaker or multiple breakers. Tripping of a single breaker is usually associated with distribution feeders, subtransmission lines, and industrial circuits. Multiple breakers need to be tripped with bus arrangements such as breaker-and-a-half, ring bus, or double bus–double breaker designs. Such designs are usually associated with higher-voltage systems.

Various arrangements are possible for trip circuit designs, which are highly influenced by individual company practices and experience. A special publication by the IEEE Power System Relaying Committee “Relay Trip Circuit Design” should be used as reference for more detail on this subject.

Regardless of the design details, some general requirements that need to be addressed when developing designs for trip circuits are as follows:

1. Adequate voltage must be delivered to the trip coil(s) to assure reliable breaker operation. All possible voltage drops that may exist in the circuit must be considered when determining voltage available at the trip coil(s).

2. Sufficient DC current must be available to operate targets on all relays that have operated. Proper tap settings and coil ratings need to be selected for target and seal-in units.
3. Care must be taken to avoid connections between DC circuits. Such connections can result in the loss of both primary and backup relays for a single failure on the DC system.
4. Currents drawn by auxiliary relays must not cause incorrect operation of seal-in units or the failure of such units to drop out properly .
5. Protection against surges caused by the operation of the various coils that exist in the control circuitry should be applied to protect other equipment connected in the circuit. This is especially important to protect delicate electronic equipment that is used in many of the more modern substations.
6. Relay coils should be connected to the negative DC bus. This is required to minimize the potential failure of such coils because of a build-up of corrosion. Coils that are directly connected to the positive DC bus are subject to corrosion with the presence of moisture.

14.22 TRIP CIRCUIT MONITORING AND ALARMS

Supervision of control circuitry that affects the ability of tripping functions to perform properly is an important enhancement for protection reliability. Important conditions for which monitoring should be considered include the following:

1. Inadequate DC tripping voltage includes low DC voltage levels (battery problems), open breaker trip coil, blown fuse in a DC circuit, or an opening in the DC circuit wiring.
2. Loss of AC potential to primary and backup relaying.
3. Loss of communication channels that are used to initiate tripping.
4. Relay problems when self-checking features are available.

A common means for monitoring availability of DC tripping voltage is by connecting lamps in the DC tripping circuit. A simple arrangement for connecting such lamps in a trip circuit is illustrated in [Figure 14.10](#).

When the breaker is closed, the red lamp provides indication of the availability of DC voltage to the trip coil. When the breaker is open, the green lamp provides similar indication. The red and green lamps also provide indication for the breaker position—the red lamp will be lit when the breaker is closed and the green lamp will be lit when the breaker is open. The lamps are usually mounted on the control panel within the substation at a location where the associated breaker is clearly identified. The lamps that are used must meet requirements of the DC circuit into which they are installed and should

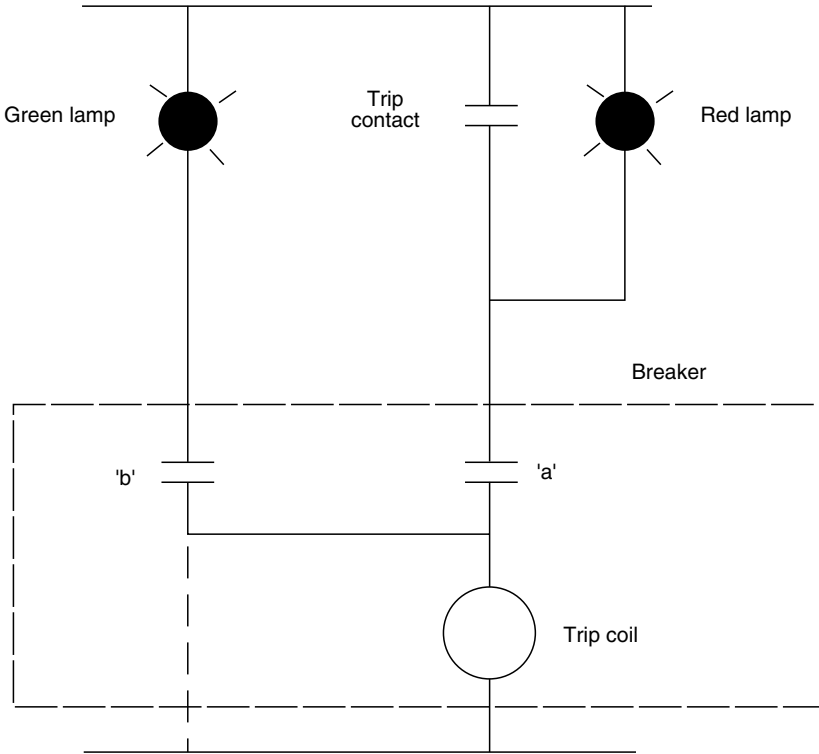

FIGURE 14.10 Illustration of lamps used for monitoring in DC trip circuits.

provide a feature to easily check for burnt-out lamps. Alarm relays may be used in addition or in place of the lamps. Such application allows for sending alarms to remote locations, which is highly recommended for unattended substations. Low DC voltage or inadequate energy in the battery bank is more difficult to detect than a complete loss of DC voltage. Under-voltage relays are sometimes applied along with devices that monitor the operating status of the battery charger. Battery systems require that periodic maintenance be performed on a regular basis. Specific gravity tests should be included to verify the integrity of the individual cells in the battery bank.

Modern substations with digital control systems employ various electronic methods for providing monitoring and alarming for various functions. Modern microprocessor-based relays contain self-checking ability, which provides local indication, remote alarming, and the blocking of relay operation for certain failures. This subject is discussed in greater detail in [Chapter 15](#).

14.23 SPECIAL PROTECTION SCHEMES

Special protection schemes are applied to detect abnormal system conditions and to initiate action as required to maintain acceptable system operation. The abnormal system conditions for which such schemes provide protection are identified conditions that may cause power system operating limits or facility ratings to be exceeded. The conditions are credible, but with low probability, and fall outside of the conditions outlined in reliability standards for which additional power system reinforcements are mandated.

Special protection schemes have been applied on power systems for many years. The underfrequency and undervoltage load shedding schemes previously discussed are forms of special protection schemes designed to provide protection for large portions of power systems when the ability for continued operation is severely challenged. Recently, special protection schemes have also been applied more commonly to protect the power system on a more localized basis. The need for such schemes, to a large extent, has accelerated with the separation of ownership of generation and transmission facilities. With separate ownership, generators are often located without in-depth consideration given to the availability of sufficient transmission facilities in the area in which the generator is proposed to be located. Instead, such factors as ownership of land and availability of fuel supply are of top priority in siting new generation. As a result, when the impact of the generation connection is analyzed, weak spots often emerge in the power system network that require the addition of power system facilities or the application of special protection schemes. The special protection schemes are applied to identify the existence of identified operating conditions that present a hazard to the power system and initiate actions to facilitate continued safe system operation. The preplanned actions initiated by the special protection schemes, at times, may be seemingly unrelated to the detected condition. Actions initiated by the schemes can include the tripping of system or generation facilities, generation rejection, generation runback, load shedding, and other automatic switching to reconfigure the network. The specific intent of the actions initiated by the special protection schemes is to prevent such events as system instability, facility overloads, or voltage levels falling outside of safe limits. Although the specifications for the installation of a special protection scheme are generally developed within the system planning function, the specific design of such schemes along with their commissioning are often performed by protection personnel, because the requirements for the schemes' controls are similar to those required for fault protection schemes.

An example application of special protection schemes relates to operating issues that sometimes surface with regard to large generating units (i.e., 800–1600 MW) connected to a high-voltage system (i.e., 500 kV). Ideally, two 500 kV lines along with a step-down transformer connected to a lower-voltage network might provide adequate transmission outlet capacity to meet the

required reliability criteria. The 500 kV lines are very expensive and utilities would be very reluctant to build any more that are required. The simultaneous loss of both 500 kV outlet lines is credible but has a low probability of occurrence and, at least in some regions, falls outside of the realm of contingencies for which power systems are mandated to be capable of withstanding. The simultaneous loss of both lines, however, might result in instability of the related generating units and possible overload of the step-down transformer. Simultaneous loss of both lines could result from a fault on one of the lines and an overtrip of the other. In addition, if the lines are double circuited, a single fault may involve both circuits. The consideration of the probability of such an occurrence has warranted the application of a special protection scheme to sense such an event and initiate correction actions. Correction action in this case would be to trip sufficient generation connected at the 500 kV bus to prevent instability or a transformer overload. Sensing logic for the scheme requires position intelligence of local and remote breakers onto which the 500 kV lines terminate. Knowledge on the status of the remote breakers is required as a line may be outage by the remote breakers that are opened while the local breakers remain closed. Relay trip outputs may also be used for scheme intelligence to allow for higher-speed operation because the trip signal will precede the opening of the breakers.

For special protection schemes as described in the previous paragraphs, a misoperation of the scheme would have significant adverse consequences. A failure to operate could result either in instability and cascading outages or in thermal damage to an expensive system facility, or both. A false operation of the scheme would result in the sudden unnecessary tripping of a large amount of generation. As such, these types of schemes must be designed for high reliability. Redundant schemes should be applied to enhance dependability and security features similar to that provided for high-voltage protective systems. Many other applications and types of special protection systems are applied at all voltage levels of power systems. The decision to employ such schemes should give consideration to the probability of the associated event occurring, the cost and complexity of the scheme and other alternatives, the benefits provided by the scheme, and the consequences of a misoperation. The associated design should also relate to the anticipated consequences of a misoperation.

In some cases, special protection schemes are only required during system operating conditions that occur on a relatively infrequent basis or only during certain seasons. In such cases, facilities should be provided such that the scheme can be readily switched in and out of service. Indication of the status of the scheme should be provided at a manned location. In addition, it is important that procedural controls that provide assurance that the scheme is in service only when required, should be established. Special protection schemes require similar maintenance and testing considerations as protective schemes.

14.24 PRACTICAL CONSIDERATIONS—SPECIAL PROTECTION SCHEMES

Special protection schemes play an important role in promoting power system reliability. Application of such schemes is usually most highly promoted by generation owners as the cost for such schemes is often considerably lesser than that for additional power system facilities. The cost for power system reinforcements that are caused directly by the generation installation are usually the responsibility of the generation owner. Utilities often prefer that system facilities rather than special protection schemes be added, as the addition of system facilities is a safer route, causes less operating concerns to the utility, and are paid for by an outside party. An arbitrator, often in the form of an independent agency, generally has responsibility for final decisions in this area. Such agencies must be vigilant that a proliferation of special protection scheme applications does not develop as a substitute for good power system design or operating practices. It is important that the party responsible for making final decisions in this area use technical merit along with a sound understanding of utility operating needs as a basis for the decisions that are made. Politics and preferential treatment need to be eliminated from the decision process. It is important that all participating parties prepare and present all relevant data and fair consideration should be given to all points of view. With regard to protection engineers, it is important that information should be provided into the decision process on the inherent reliability that can be expected from proposed schemes. Once the decision is made to apply a special protection scheme, the focus of the protection engineer should be on providing full support for the project and a commitment to developing an effective and reliable design.

BIBLIOGRAPHY

- Berry, D.H., Brown, R.D., Redmond, J.J., and Watson, W., Underfrequency Protection of the Ontario Hydro System, CIGRE, 1970, paper 32–14.
- Dalziel, C.E. and Steinbach, E.W., Underfrequency protection of power systems for system relief, load shedding system splitting, *IEEE Trans. Power Appar. Syst.*, PAS 78, 1959, pp. 1227–1238.
- IEEE Power System Relaying Committee Working Group, A status report on methods used for system preservation during underfrequency conditions, *IEEE Trans. Power Appar. Syst.*, PAS 94; 1975, pp. 360–366.
- IEEE Power System Relaying Committee, Automatic reclosing of transmission lines, *IEEE Trans. Power Appar. Syst.*, PAS 103, 1984, pp. 234–245.
- Lokay, H.E. and Burtnyk, V., Application of underfrequency relay, for automatic load shedding, *IEEE Trans. Power Appar. Syst.*, PAS 87, 1968, pp. 776–783.
- Power Systems Engineering Committee, Proposed terms and definitions for power system stability, *IEEE Trans. Power Appar. Syst.*, PAS 101, 1982, pp. 1894–1898.

15 Microprocessor Applications and Substation Automation

15.1 INTRODUCTION

Technological developments over the past several decades have dramatically changed the “way of life” throughout the world. Developments and advances in microprocessor technology have been a primary driver of these changes. It was not too long ago that major sources of information and recent news were encyclopedias, newscasts, and newspapers. In recent times, just about anything you want to know can be found on the Internet within a few minutes. Not more than a decade ago, personal communications required hard wire connections or cumbersome and unreliable radio signals. Currently, a large portion of the population of the world can communicate reliably using small wireless devices that can easily fit into a shirt pocket. All sorts of gadgets have emerged to keep people entertained. Computational power has grown at an exponential rate with similar reductions in cost. When electronic calculators were first marketed in the 1960s, the cost was upward of \$400—a much more powerful and smaller calculator today can be purchased for about \$20. Computers, which are at present considered as throw-away units, have power that required a room full of equipment during the earlier years when computers were first developed. Power system protection has not been left out of this revolution. In recent years, microprocessor-based protection devices, programmable controllers, and digital communication systems have dominated the market and have become the norm for a large majority of new applications. Such developments have changed the landscape of substation control rooms. Massive amounts of wiring have disappeared, control boards have been greatly reduced in size, and CRTs are used to operate the substation and display substation configuration, alarms, and events. Change, however, does not come without the creation of a new set of problems and concerns. Engineers need to become familiar with the new technology that always seems to be in a state of change along with completely new types of products.

More data need to be generated and documented. Impact and detection of failures within the equipment creates concerns. There is little question, as demonstrated by experience, that the benefits of the application of digital-based protection, control, and communication systems far outweigh the disadvantages. Protection engineers are encouraged to embrace technological advances and take advantage of related opportunities that are presented for making protection and control systems more efficient and reliable, for improving power system operations, and for acquiring a better understanding of the manner in which power systems behave.

15.2 MICROPROCESSOR-BASED RELAY DESIGNS

A multitude of literature is available in which designs of microprocessor-based relays (numerical relays) are discussed in great detail. A discussion of this subject material is neither the aim nor is it within the scope of this book. From a practical standpoint, while this subject is highly significant to academia and engineers and scientists involved with the design of protective products, a broad knowledge of such design details is not crucial to the process of applying such products for the protection and control of power systems. Although it is desirable for protection application engineers to have a basic understanding of how the related products work in order to select those that best fit specific applications and operational preferences, a detailed understanding of internal workings is not a requirement for the application process. Furthermore, time limitations that are usually imposed on most practicing protection application engineers often limit the amount of study that can be devoted to this subject. Similar to electromechanical relays, numerical relays receive, and act upon, current and voltage signals as measured at designated locations throughout the power system. These signals are periodically sampled and filtered. The sampled values are instantaneous values as measured on the waveform of the associated parameters that are passed on to an analog–digital converter. The sample rate for protective functions are limited by the speed at which operational decisions need to be made. A typical range of sample rates might fall into the area of 4 to 16 per cycle. Higher sample rates may be used for other functions such as metering and oscillography since time for providing an output is not critical. The function of the analog–digital converter is to convert the sampled values into digital form, usually an 8 or 16 bit word. The digital data are then passed along to the microprocessor in which algorithms act upon it to mathematically produce phasor representations of the measured quantities. Various algorithms then manipulate the phasor quantities to produce results required for making relaying decisions.

Protection engineers need to identify the input quantities required by the specific type and model of numerical relay applied. As noted, three-phase current and voltage are normally required. Other input requirements depend on the needs of specific protection and control functions that are available in

the relay and that are planned to be used. Additional input quantities that might be needed include signals that indicate breaker position, that reset targets, that enable pilot logic, that indicate the status of pilot receivers, along with various other types of similar signals.

Some microprocessor relays are designed as discreet replacements for electromechanical relays. Such designs often allow the relay to be directly inserted into the case that housed the electromechanical relay that is replaced. Such designs fit a specific need in which it is desired to replace older electromechanical relays without any corresponding wiring changes. The more common design for numerical relays involves the incorporation of a variety of protective and control functions within a rack-mountable case with specific connections for inputs and outputs. The number of protection and control functions available in numerical relays can vary from a few to meet simple or specialized needs to a number suitable for providing complete protection for a line terminal or a generator. A simple design may include several overcurrent elements. A design that is little more complex may add automatic reclosing functions along with the overcurrent elements. As noted earlier, a more complex relay may include all functions required for protecting a specific power system facility along with logic to provide control for the facility.

15.3 PROGRAMABLE LOGIC CONTROLLERS

Many substation designs that use microprocessor protective relays have used programmable logic controllers (PLCs) for the associated control design. PLCs have been developed to replace electromechanical relays as logic elements. PLCs use a digital computer with a stored program, which emulates the interconnection of many relays to perform certain logical tasks. The programming for PLCs is keyed in as input and displayed as “ladder” diagrams. Such diagrams represent logic as it occurs in sequence in an elementary diagram form. The term ladder is used for these diagrams because they resemble a ladder and logic flows from rung to rung since each line in the ladder is scanned sequentially by the computer. A PLC has numerous input terminals through which are inputted logical states from a variety of elements such as sensors and switches. Logical states can have only two positions, which can be called “high” and “low,” “on” and “off,” or “1” and “0.” PLCs also have numerous output terminals that can be used to initiate other events such as to operate trip coils, energize solenoids, or light lamps. The PLC program dictates which output gets energized under which input conditions. While the program by itself appears as a ladder logic diagram, the related contacts and relay coils are imaginary and imbedded into the control software. PLC programs are entered and viewed by using a computer connected to the PLC’s programming port.

PLCs have the ability to communicate with numerical relays and other digital devices along with the ability to be monitored and controlled from remote

locations. In recent times, numerical relays are designed with continually increasing processing power and with the ability to internally perform most of the logic, which had required the use of PLCs in the past. Substations are currently designed with all protection and control performed within the numerical relays, with trip circuits as the only control circuit that is hard wired.

15.4 APPLICATION OF MICROPROCESSOR RELAYS

When microprocessor-based relays were initially introduced to the market, protection engineers at the utility level often confronted this new technology with a degree of confusion and apprehension. With electromechanical relays, specifying settings was a straightforward process, once the required setting parameters were developed. With microprocessor relays, a multitude of input quantities were required, the meaning of a variety of new and vague terms needed to be understood, and voluminous instruction books that were often difficult to understand needed to be analyzed. The protection engineer was also highly concerned about the ability of the new microprocessor-based devices to withstand the harsh environment that a power substation presents to delicate electronic equipment. Furthermore, protection personnel tend to be highly conservative with regard to the application of new technology. It is safer to adhere to what has been used in the past as the benefits derived from trying something new are slow to be recognized but problems encountered with new applications pose significant risks. Although some of these challenges still exist, experience has eased concerns with regard to reliability as well as for setting and testing requirements. In addition, the quality and clarity of instruction manuals have improved and features have been incorporated into designs that facilitate the setting process.

However, developing basic setting specifications for numerical relays is a tedious process that requires significant input data but, for the most part, is relatively straightforward. A basic understanding of Boolean expressions and methodologies is helpful in developing the required programming to obtain the desired logic and for effectively using the full power that is designed into numerical relays. The capabilities and power that are built into microprocessor relay designs are continually expanding. In addition to providing an array of protective functions, capability to fulfill most of the control and data acquisition requirements at substations is provided. Many modern numerical relays possess the power to replace other digital devices that are required within substation control and data acquisition systems such as PLCs, RTUs, meters, and control switches. An obstacle to the practical use of the expanded power that is made available in microprocessor-based protective devices is the complexity of the programming that is required to use this power. Protection engineers are not necessarily proficient in programming techniques and, as such, they may be hesitant to apply numerical relays such that their full capability is used.

15.5 PROGRAMING OF MICROPROCESSOR RELAYING

An understanding of programing techniques is required to effectively use the many features and flexibility that are designed into modern microprocessor-based relays. Programing tools available for programing modern numerical relays include Boolean operators, control equation elements, binary elements, analog quantities, and math operators.

15.5.1 BOOLEAN ALGEBRA

Knowledge of Boolean algebra and its relationship to logic created by electrical circuits is important to facilitate the task of programing numerical relays. It is advisable for protection engineers to obtain a degree of fluency in this subject. Many good texts and courses are available for obtaining knowledge of this subject area. A brief overview of some basic fundamentals follows.

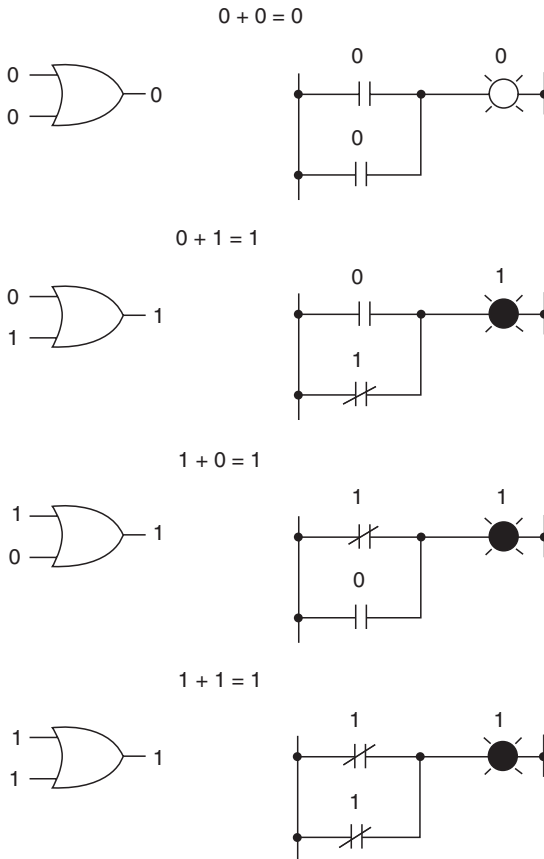

FIGURE 15.1 Expressions for Boolean addition—"OR" gate.

In Boolean arithmetic, terms can only have two states—they can be either a 1 or a 0. Rules for Boolean addition are illustrated in the following equations:

$$0 + 0 = 0, \quad 0 + 1 = 1,$$

$$1 + 0 = 1, \quad 1 + 1 = 1.$$

It does not matter how many terms are added, the sum cannot be any larger than 1 since, as noted earlier, only 1 and 0 can exist:

$$0 + 1 + 1 = 1, \quad 1 + 1 + 1 + 0 = 1, \quad 1 + 1 + 0 + 1 + 1 + 0 = 1.$$

Boolean addition corresponds to the logical function of an “OR” gate and is representative of parallel contacts in an electric circuit. The basic equations for Boolean addition along with its logical “OR” gate and electric circuit representation are illustrated in [Figure 15.1](#).

Following are the equations that represent the rules for Boolean multiplication:

$$0 \times 0 = 0, \quad 0 \times 1 = 0,$$

$$1 \times 0 = 0, \quad 1 \times 1 = 1.$$

Boolean multiplication corresponds to the logical function of an “AND” gate and is representative of series contacts in an electric circuit. [Figure 15.2](#) illustrates expressions for Boolean multiplication.

Boolean algebraic variables are denoted by capital letters. Boolean variable can only have one of two values—a 1 or a 0. Every variable has a complement—the opposite of its value. If a variable A has a value of 1, then its complement has a value of 0. The symbol used for the complement of a variable is denoted by a bar over the associated capital letter. A complement is referred to as a logical inversion and corresponds to the logical function of a “NOT” gate. Electrically, a logical inversion is equivalent to a normally closed contact. Expressions for Boolean complementation are illustrated in [Figure 15.3](#).

As in mathematics, identities also exist in Boolean algebra. These identities are derived from the unique bivariable nature of Boolean variables. Basic Boolean additive and multiplicative identities are illustrated in [Figure 15.4](#).

Boolean algebra also contains cumulative and associative properties. Cumulative property of addition:

$$A + B = B + A.$$

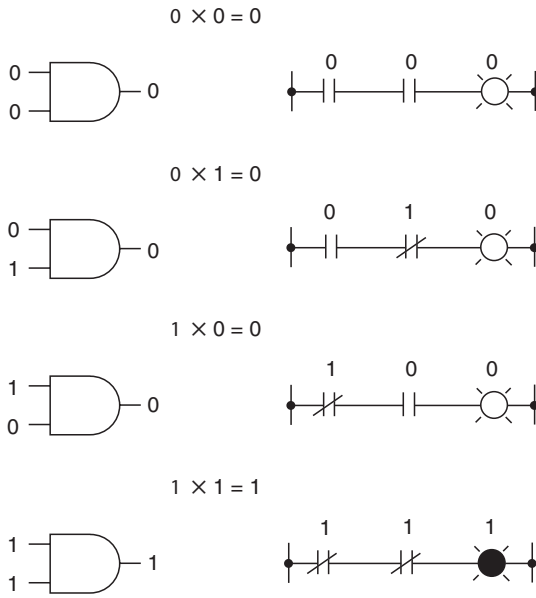

FIGURE 15.2 Expressions for Boolean multiplication—“AND” gate.

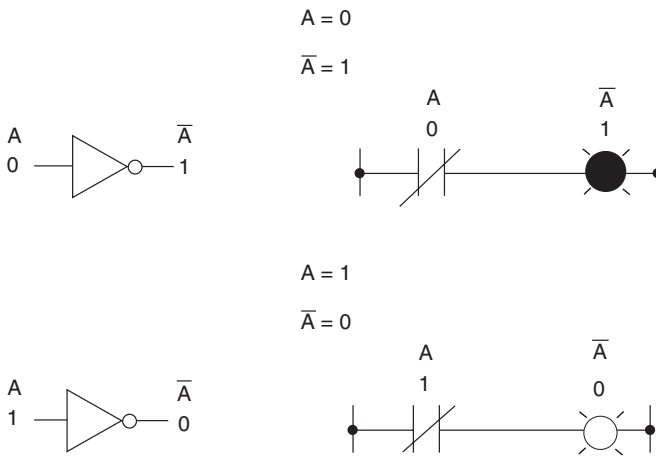

FIGURE 15.3 Expressions for Boolean complementation—“NOT” gate.

Additive	Multiplicative
$A + 0 = A$	$0A = 0$
$A + 1 = 1$	$1A = A$
$A + A = A$	$AA = A$
$A + \bar{A} = 1$	$A\bar{A} = 0$

FIGURE 15.4 Basic Boolean identities.

Cumulative property of multiplication:

$$AB = BA.$$

Associative property of addition:

$$A + (B + C) = (A + B) + C.$$

Associative property of multiplication:

$$A(BC) = (AB)C.$$

Distributive property:

$$A(B + C) = AB + AC.$$

Some other operators used in Boolean expressions include comparisons (<, >, =, etc.), parentheses, and rising and falling edge triggers. Numerical relays often use symbols to represent Boolean operators (i.e., + = OR, * = AND, ! = NOT).

Truth tables are often used as a first step in the programming process to illustrate exactly what the logic circuit must perform. Truth tables provide a systematic manner for setting up the associated Boolean expressions. To promote programming efficiency, the initial expressions developed from the truth table should be reduced, using the laws of Boolean algebra, to a simplified form. The required logic circuit can then be developed from the simplified expression. [Figure 15.5](#) illustrates truth tables for a variety of logic gates used in logic diagrams.

The following example illustrates the process of developing logic for control circuits:

Three pilot relaying systems are applied on a very important transmission line. In order to enhance security of the line it is desired that trip outputs from two out of the three pilot systems must be present for a trip of the line to be initiated. A 1 represents a trip output from a pilot scheme and a (0) represents

A	B	Output
0	0	0
0	1	1
1	0	1
1	1	1

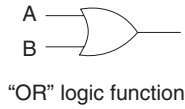

A	B	Output
0	0	0
0	1	0
1	0	0
1	1	1

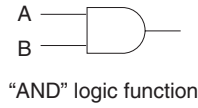

A	B	Output
0	0	1
0	1	0
1	0	0
1	1	0

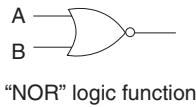

A	B	Output
0	0	1
0	1	1
1	0	1
1	1	0

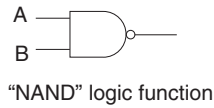

A	Output
0	1
1	0

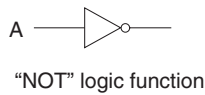

A	B	Output
0	0	0
0	1	1
1	0	1
1	1	0

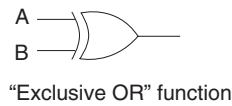

FIGURE 15.5 Logic gates and associated truth tables.

no trip output from a pilot scheme. The associated truth table would look as shown in [Table 15.1](#).

A' will be used to indicate a complement. From the four conditions in the truth table for which an output is indicated, the following Boolean equations can be developed:

TABLE 15.1**Truth Table for 'Two-Out-Of-Three' Pilot Logic**

Pilot 1 = A	Pilot 2 = B	Pilot 3 = C	Output
0	0	0	0
0	0	1	0
0	1	0	0
0	1	1	1
1	0	0	0
1	0	1	1
1	1	0	1
1	1	1	1

Line 4— $A'BC = 1$

Line 6— $AB'C = 1$

Line 7— $ABC' = 1$

Line 8— $ABC = 1$

A Boolean equation could then be developed to cover the conditions given earlier:

$$\text{Output} = A'BC + AB'C + ABC' + ABC.$$

A logic circuit could be developed to match the Boolean equation stated earlier; however, it would be rather complex. By using rules of Boolean algebra, the aforementioned equation could be reduced to

$$\text{Output} = AB + BC + AC.$$

Whereas the logic requirements for this case were more or less intuitively obvious as the required logic was quite simple, for more complex systems it is easy to develop errors when shortcuts are taken and intuition is used instead of a step-by-step process. It is highly recommended that when developing logic programs, truth tables and a systematic approach be used to facilitate obtaining a valid result. The associated logic circuit for the aforementioned output equation is illustrated in Figure 15.6.

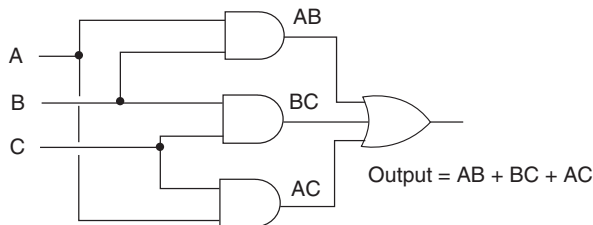

FIGURE 15.6 Logic circuit that satisfies output = $AB + BC + AC$.

15.5.2 CONTROL EQUATION ELEMENTS

Control equation elements are a collection of storage locations, timers, and counters that are available in the relay for the user to customize the operation of the relay and to provide logic in data for substation automation. These elements include control equation variables developed by programmed Boolean equations, control equation math variables that are developed by math control equations, latches, and conditioning and sequencing timers. They also provide storage locations for remote bits that are communicated to the relay to identify the status of other equipment.

15.5.3 BINARY ELEMENTS

Binary elements are the outputs that are the result of internal relay logic. The logic that controls the binary elements can be preprogrammed or programmed by the user. Binary elements can be used in Boolean equations to create other logic or to initiate various actions such as the trip output, close output, triggering of an event report, and so on.

15.5.4 ANALOG QUANTITIES

Analog quantities are current and voltage quantities that are received, measured, and calculated. Analog quantities may be instantaneous, average, or RMS values of the associated current or voltage. Math operators are used to program the analog quantities.

15.5.5 MATH OPERATORS

Math operators are used for writing mathematical control equations using analog values. Math operators include familiar operations such as addition, subtraction, multiplication, division, square root, logarithms, exponents, trig functions, and so on. Programming mathematical equations by the user is usually associated with control functions rather than protective functions.

15.5.6 SETTINGS

In addition to programming for logic equations, microprocessor relays require inputs to assign the level and time delay at which various binary elements change state (set points for protective functions, timer setting, etc.) and to enable or disable various functions that are available in the relay. Inputs are also required to identify phase rotation, current transformer and potential transformer ratios, time-current characteristics that are required for protection functions that operate with inverse time delay, display indications, and so on. Many numerical relays provide for a wide selection of protective functions that can be selected for use along with a number of setting groups in which different settings can be applied. Only one setting group can be active at one particular

time. The different settings in the groups can be applied to provide the required protection for different operating conditions. The active setting group can be selected or changed automatically or manually. Protective functions that are not desired to be used should be disabled. With the vast array of features available, numerical relays specifically require a significantly large amount of input data. In dealing with such large amounts of data, the protection engineer must compile the input requirements with care and due diligence to avoid errors. A simple slip of a digit or an incorrect sign can have serious negative impacts on the reliability and safety of the related power system.

15.6 ATTRIBUTES OF MICROPROCESSOR-BASED RELAYS

Electric utility practices in the United States as well as in other countries substantiate claims that microprocessor-based protective relay systems have gained widespread acceptance in the industry. The vast majority of relays currently manufactured and purchased are microprocessor based. Some of the major beneficial characteristics of numerical relays that have propelled this movement include the following:

1. More protection for less cost.
2. Wiring simplification.
3. Greater flexibility.
4. Less maintenance requirements.
5. Reduction in panel space—less devices required.
6. Event recording capability.
7. Ability to calculate and display distance to fault.
8. Data acquisition for metering.
9. Built-in logic for control and automation.
10. Self-checking capability.
11. Communication capability—ability to design enhanced protection schemes.
12. Capability for remote interrogation and setting application.
13. Ability to change settings automatically based on system conditions.

Some disadvantages of using microprocessor-based relays that have been cited include the following:

1. Single failure may disable many protective functions.
2. Instruction manuals are complicated and difficult to understand.
3. Excessive input data required for settings and logic.
4. Frequent firmware upgrades—create tracking and documentation problems.
5. Difficulty in matching input software with relays, especially when relays have been field modified.

The following sections provide a discussion of some of the significant features and issues that relate to the application of microprocessor-based relays for power system protection.

15.7 PROTECTION ENHANCEMENTS

Significant features of microprocessor-based relays that serve to enhance protection previously available through application of traditional relaying include the following:

1. Numerical relays allow for a variety of protection systems to be applied with minimal additional cost.
2. Changes can be made within microprocessor-based relaying systems with ease.

Before the availability of microprocessor relays, the logic and set points incorporated into protective systems were fixed—modifications required manual manipulation of setting adjusters or physical changes to the wiring configuration. Flexibility was highly limited by the time and cost for making such changes and by the fact that, in many cases, facilities were required to be taken out of service while changes were made. Application of microprocessor relaying systems along with a local area network provides a means to easily modify logic and settings and to easily apply protective schemes that previously could not be justified.

15.7.1 DISTRIBUTION PROTECTION SYSTEMS

The use of microprocessor-based relaying at distribution substations has allowed for the application of protective schemes that previously were too complex or costly to be justified. One example is the application of breaker failure relaying. Most numerical relays come equipped with timers incorporated into the software that are available for application as desired by the user. These timers along with some simple programming can be set up to send a signal through the relay's communication port to trip backup devices, should a feeder breaker fail to interrupt within a prescribed time after operation of an associated protective relay. Breaker failure relaying has been sparingly applied in the past at the distribution level because of the complexity and cost involved with electromechanical breaker failure schemes. With microprocessor-based relaying, it is also a relatively simple matter to provide backup relaying for protection applied on distribution lines. Backup protection can be obtained by programming the alarm contact of each feeder relay to trip the associated feeder breaker with permission from the operation of a backup overcurrent relay. Closing of the alarm contact occurs when the self-checking mechanism of a relay indicates a problem within the relay. Overcurrent relaying that is supplied

by current flowing through the substation transformer, in many cases, is applied for bus or transformer protection. The overcurrent elements that exist for this relaying can be used for the overcurrent supervision function for the feeder backup protection at minimal additional cost.

“Fast” bus protection can also be implemented at distribution substations when microprocessor relays are applied with relative ease and low cost. As indicated, most digital relays provide a number of overcurrent functions that can be used at the discretion of the user. To implement a fast bus protection scheme, low-set instantaneous overcurrent relays are programmed in each feeder relay to send a blocking signal to the main bus overcurrent relay. The bus relay is programmed to trip through an overcurrent relay with a short time delay. The bus overcurrent relay is set to pick up at a level slightly above that of the blocking overcurrent relays on each feeder. For faults on a feeder, if sufficient fault current exists to pick up the bus overcurrent relay, the blocking overcurrent relay on the faulted feeder will also always operate and block tripping of the bus protection. If the fault is on the bus, none of the feeder overcurrent relays will operate, and the bus scheme will operate after a short time delay. A time delay of about six cycles will usually be sufficient on the bus scheme. The use of a fast bus overcurrent scheme is applicable when the feeders operate in a radial configuration.

A perplexing condition that has caused problems at distribution substations in the past is unbalances that result when a high-side transformer fuse opens. Distribution transformers are commonly connected in delta on the high side and wye-grounded on the low-side. With such a connection, when one high-side fuse opens, two of the low-side phase-to-phase voltages reduce to 87% of normal and the remaining phase-to-phase voltage drops to zero. Phase-to-ground voltages in two phases will drop to 50% of normal whereas the remaining phase-to-ground voltage remains near normal. Motors supplied from the substation will be damaged if they are left connected for any significant period of time under such unbalanced and low-voltage conditions. Larger three-phase motors may be individually protected against unbalances. Smaller three-phase motors and single-phase motors, however, may not be equipped with such protection. Utilities have received many complaints and lawsuits on account of the motors that have failed when continued operation of a distribution substation with a blown high-side fuse was allowed. Refrigerator and air-conditioning motors are especially vulnerable under such conditions and one substation may supply many hundreds of such motors. Application of microprocessor-based relays makes it relatively easy to detect the earlier mentioned blown fuse condition at distribution substations. Microprocessor relays are usually equipped with undervoltage elements that can be programmed to detect voltage conditions representative of a blown high-side fuse on a delta-wye connected transformer and to initiate appropriate action to disconnect affected loads.

Typical settings that could be programmed into the relay might be such that an output is initiated if, at the same time, any phase-to-phase voltage is less than 40% of nominal AND any phase-to-phase voltage is above 70% of nominal. Such a setting will detect conditions that exist for a blown high-side fuse condition but will not initiate an output for a blown fuse on the potential transformer that supplies the relay. For a blown PT fuse, two low-side phase-to-phase voltages drop to 58% whereas the other phase-to-phase voltage remains normal.

The ability to automatically change settings on numerical relays can also provide beneficial flexibility at distribution substations. Settings can be reduced at light load conditions to obtain greater sensitivity for fault coverage. Fuse-saving logic can be removed from service based on the time of day to lower the potential for momentary outages during those times when sensitive electronic equipments are most likely to be in use. Settings can also be increased to higher pickup levels following a permanent outage to allow for greater cold-load pickup capability.

It should be noted that many of the schemes as described earlier in this chapter could be obtained with traditional electromechanical relays. Such applications, however, would require the application of more relays and even more complex wiring. For this reason, many utilities had not considered the benefits gained to be worth the additional costs and complexities. With microprocessor relays applied, these schemes, along with many others depending on specific applications, can be put in place by applying a little ingenuity along with some simple programming. The ease of application of a variety of logic is a major part of the attractiveness that microprocessor-based relays bring into the protection arena.

15.7.2 TRANSMISSION PROTECTION SYSTEMS

The flexibility provided by numerical relays can provide significant benefits for protecting transmission systems. Many of the microprocessor-based relays that are designed for transmission line protection offer a variety of distance characteristics that can be selected by the user. The best characteristic that fits a particular application can therefore be applied and easily modified if system conditions change. For example, for a short line, a quadrilateral characteristic might be best to provide the desired arc resistance coverage. For long lines, distance characteristics that are specially designed to provide immunity from operating on load are available on many numerical relays. If the system is rearranged such that short lines are made longer, long lines made shorter, or multiterminal lines are created, the related distance characteristics can easily be changed to best fit the specific need.

Higher voltage substations often use a bus tie breaker that can be substituted for any line breaker. The bus tie breaker is ideally used when a breaker is taken out of service for maintenance or on account of a failure of the

breaker. With multiple setting groups that are available on most numerical relays, application of such relays on bus tie breakers allows the settings to be easily changed to match those requirements for the particular line for which the tie breaker currently provides termination. In addition, when lines are arranged in a “loop” system, the lengths of lines can be increased when a breaker is bypassed. With multiple setting groups, settings on associated numerical relays can be easily modified to accommodate the increased line lengths. If desired, such setting changes can be implemented automatically by using communication channels and monitoring the position of the breaker bypass switches.

15.8 MULTIFUNCTIONAL CAPABILITY

Microprocessor relays can be designed with a significant amount of capability built into one box. In addition to multiple protection functions, programmable control logic is incorporated, which can eliminate the need for most of the auxiliary type relays that was required with the use of predecessor type relays. The features that are available in numerical relays obviously have significant benefits with regard to reducing panel space and wiring requirements. One box can practically provide all the protection and control requirements for a generator, a line terminal, and other system facilities.

Concerns related to the application of numerical relays with multifunctional capability are mainly directed toward reliability issues. With complete protection and control contained within one device, it is feared that a single failure may disable all protection that is provided for a system facility. Common-mode failures can also remove all protection from a facility if multiple devices of similar type are applied. Fear also exists that failures may remain hidden and even when uncovered, may be difficult to repair. While repairs are made, a concern has existed that it may be necessary to take important system facilities out of service for a significant period. These concerns had slowed the acceptance of multifunctional devices. Tradition and experience have conditioned protection engineers to recognize that it is not wise to put all eggs in one basket. Controversy remains in this area. Some advocates feel that microprocessor capability can be more effectively applied with more separation of components. Regardless of what future developments and preferences may bring, a growing acceptance of applying multifunctional digital systems for protection and control has been noted in recent years. The cost of multifunctional protection devices is modest and has been trending lower in relation to the amount of power that they contain. With cost relatively low, it has become common practice to apply two or more multifunctional relays on each protected facility. It has also become common practice to store one or more spare relays for each type used as a replacement in the event of a failure. As a result, repairs simply require the failed device to be slid out of its case and

the spare device slid in. To avoid the possibility of common mode failures, protection engineers often use relays produced by different manufacturers for protection of a single facility. Performance of the related protective equipment has improved to a level that such practice has been relaxed within many utilities. Protection engineers prefer to use as few different products as possible from the standpoint of time required to learn about requirements for settings, programing, and testing. Some utilities therefore prefer to allow products from the same manufacturer to be used as redundant protection. Sometimes different models are mandated to lower the probability of common-mode type failures. It is enough to say that experience has shown that the reliability of microprocessor-based relaying has improved to the point that multifunctional applications are becoming routine. For protection of less critical and less expensive facilities, the use of a single multifunctional device is often considered acceptable. It is probably certain that this trend will continue and grow in the future as designs of protective devices continue to improve along with related reliability.

15.9 WIRING SIMPLIFICATION

A significant benefit that is made possible with the application of microprocessor relays is the reduction in the amount of wiring required for protection and control. With electromechanical relays, wires must be connected to relay terminals that connect to contacts of each protective function applied. Considerable wiring is also required to connect auxiliary relays, reclosing relays, and various other control devices in order to develop the desired protection and control logic. As a result, the required wiring for electromechanical designs is usually voluminous and complex, resulting in considerable cost and potential for errors. With microprocessor relays, all the protective functions and associated logic can exist within a single case, eliminating the need for most of the interconnection wiring that had previously been required.

The computational ability of microprocessor relays can also serve to simplify wiring requirements. For example, when applying electromechanical differential relays on transformers with delta- and wye-connected windings, the current transformers on the wye-connected side of the transformer must be connected in delta for the differential relay to function properly. Developing the wiring for the delta connection of the CTs requires careful analysis to assure that the arrangement of the connections is proper. When applying a microprocessor-based differential relay on such transformers, the delta connection for the current transformer typically is not required. Instead, the relay is merely told of the type of connection that is involved, and equivalent currents that would be provided by the delta-connected CTs are calculated within the relay. In addition, the microprocessor relay can provide magnitude and angle checks to ensure all connections and inputs are correct.

15.10 EVENT REPORTS

The ability of microprocessor-based relays to record and display event reports has provided protection engineers a powerful tool for analyzing the nature of power system disturbances and the related performance of protection and interrupting devices. In the past, engineers had to rely on information received from fault and sequence-of-events recorders to analyze system disturbances. On account of the relatively high cost of such devices, they were usually installed only at the vital high-voltage stations. With the application of microprocessor-based relays, the same type of information is available at every location where such devices are applied.

Most microprocessor-based relays provide event reporting as a standard feature. Event reports are a stored record of what the relay saw and how it responded during a system fault or other type of event. During such events, fixed or settable triggers within the relay initiate recording of the state of all relay elements and programable logic, the status of input and output contacts, sampled analog currents and voltages, and the related relay settings that are currently active in the relay.

15.10.1 TYPES OF EVENT REPORTS

A report that contains all the information recorded by the relay is referred to as a “full report.” The number and type of analog channels and relay elements that are monitored will vary depending on the particular relay model. Event reports are typically formatted as ASCII text files that are read vertically. The data are displayed in columns with each column representing a point in time. Time intervals depend on the sampling rate, which typically varies from 4 to 16 samples per cycle. Relays often offer flexibility for selection of the display rate. Four samples per cycle might be chosen to obtain a quick overview and 16 samples selected to view detailed oscillography. Event reports are limited in length because of storage limitations of the relay. Lengths can vary from about 11 cycles up to 60 cycles of data. The maximum amount of storage and display capability is continually increasing over time as processors are designed with more and more power. A portion of the length of the recorded event is assigned to provide prefault and postfault information. Event reports normally display analog values that have been filtered within the relay. Many relays also permit unfiltered values to be displayed to allow observation of harmonics and DC offset, if desired. Event reports can be viewed as text files using a personal computer and commonly available terminal emulation software. Manufacturers also provide specialized software for viewing event report data. Using such software can be highly beneficial for allowing the user to easily view the data as step-by-step instructions are provided. Such software tools allow automatic capability for reading data, for displaying waveforms along with the status of digital

elements, and for displaying calculated phasor magnitudes, phase angles, and symmetrical component values. Customized software also allows for scales to be manipulated, for adding notes and labels, and for exporting data to other files. Using such specialized software can greatly facilitate the process of analyzing event reports.

In addition to the full event report, modern numerical relays are capable of generating a variety of abbreviated reports. These include historical reports, automatic summary messages, and sequence-of-events reports.

Historical reports provide a record of what has happened at a location over time. A new entry is added to the history report every time a report is created by the relay. History reports are displayed chronologically starting from the latest event and working backward. Scanning of history reports allows a brief summary of all the events that have occurred at a location. Events are often scanned to select items for further review. A scan of historical events may be initiated by a particular current need or concern or by a general review that is conducted regarding protection performance. For each event, the history report will usually display the date, time, phases involved in the fault, and the calculated distance to the fault.

Reports in the form of automatic summary messages are sent to the communication ports of the relay whenever they are generated. The message can be sent to a master station at a location where the analysts reside. The sending of summary message reports prevents the need to poll the individual relays to identify the availability of new event data. It is also possible to extract certain information pertinent to operations such as information related to fault location and phases involved in the fault for sending to system operators over the SCADA system.

Sequence-of-events reports are also created by many modern numerical relay designs. The elements monitored by this report are selectable by the user. When any selected element changes state, the relay time-tags the change and documents the change in the report. The sequence-of-events report allows the timing sequence of operations within the relay to be viewed and analyzed. Information pertaining to the sequence in which elements operated within the relay can be highly valuable when analyzing power system disturbances.

15.11 COMMISSIONING AND PERIODIC TESTING

Traditional commissioning for placing protection and control facilities in service involves several steps:

1. Bench testing of relays to assure proper operation
2. Application of specified settings
3. Verification of proper wiring
4. Functional tests of all protection and control systems
5. In-service tests

The first four steps listed above are performed before energization. The final step is performed when the system is energized and confirms that proper values and phase angles exist for all quantities supplied to the relaying and metering.

Periodic testing of electromechanical relays is performed to assure that the calibration of the relays remains within allowable limits and to verify that the capability of the protection system to trip the breaker remains intact. Electromechanical relays are subject to a variety of environmental factors that can affect their operational characteristics over time. As such, it is important for the devices to be periodically exercised and checked to assure that proper operation is maintained. Reliability councils often mandate schedules for periodic testing of protective facilities on the higher-voltage systems. Some regions require that test reports be submitted to verify that periodic testing is performed as mandated.

When commissioning numerical relays, the same objectives exist as that for electromechanical relays. Tests are required to verify that the relay operates properly, that the overall protective scheme functions as designed, and in-service readings are correct. Because of the nature and capabilities of numerical relays, however, the scope and techniques required for the associated tests differ from those required for electromechanical relays.

Functional testing of numerical relays is often performed to assure that the relay operates as per design specifications. Much of the operation is controlled by the applied software. Practices for functional testing of numerical relays vary among utilities with a tendency to be more relaxed than that for electromechanical relays. As the same software will be applied to all similar models, a common practice is to perform such tests only once on a specific model of a microprocessor-based relay. The test verifies that the software performs properly and the hardware of the specific relay tested operates according to design. Such testing also allows protection personnel to become familiar with the operational features of the relay. Once a relay model is thoroughly tested, manufacturer's tests are accepted as sufficient to properly verify operating hardware. If hardware problems do exist in an individual relay, it is felt that any such defects will be detected during tests that are performed later in the commissioning process.

The process of applying settings on numerical relays differs significantly from that for electromechanical relays. Numerical relays do not have taps, levers, or trim pots to adjust for applying settings. Rather, settings for numerical relays are loaded into the relay in electronic form. In addition to settings for protective elements, electronic inputs will also define configuration and logic that are desired for the relay. Testing of settings is performed by applying values to the relay and checking that operation occurs as expected based on the setting parameters. As a number of protective elements often operate a common output contact, it is sometimes necessary to disable some

elements to test the pickup and timing of a specific protective element. Because numerical relays incorporate a large portion of the protection and control logic within software, checks required to verify proper wiring are significantly less than those for electromechanical relays. Testing of logic in numerical relays requires confirmation that all inputs, function blocks, controls, outputs, alarms, and switches operate as intended. A hard copy of the desired logic diagram should be available to test personnel to facilitate testing and such diagrams should be kept as part of the permanent records for future reference. It is beneficial to test personnel that hard copies of logic diagrams are maintained in files at the substation to facilitate testing, especially during emergencies. The sequence-of-events capabilities that are available in numerical relays can be used to facilitate the process of testing logic. In addition, specialized software is often made available for testing logic and setpoints as well as the dynamic and adaptive features that are commonly built into numerical relay characteristics. Microprocessor-based relays often allow flexibility in the manner in which targets and other records developed by the relay are labeled and stored. Tests need to be devised to assure that all such recording is functioning as intended. Displayed values of measured currents and voltages that are provided by numerical relays can facilitate the testing process as soon as the correctness of these values has been verified. Displayed currents and voltage values are highly valuable for the in-service testing that is required to verify proper connections and ratios of associated instrument transformers.

15.12 SETTING SPECIFICATIONS AND DOCUMENTATION

A major difference between electromechanical relays and numerical relays is the significantly greater amount of data that needs to be transmitted for specifying settings for numerical-type relays. A good tracking system is essential to facilitate and assure that proper settings are applied to the numerical relays and to facilitate trouble-shooting when problems occur. Recommended features of the tracking system should include the following:

1. Setting specifications should be transmitted in both electronic and hard-copy form.
2. Logic diagrams should be developed to supplement input specifications.
3. A formal and consistent file-naming system should be developed and used, which clearly and uniquely identifies each specific device and its associated settings.
4. A feedback system, which provides for verification that downloads of applied settings and related specified “as-sent” settings are identical.

Tracking systems can take many forms depending on the preference of the user. The important thing is that the system needs to be immune to blind spots and is used consistently throughout the associated power system. It is recommended that standard industry nomenclature be used in the formatting and file-naming system to the extent possible. This practice can be helpful when setting data need to be shared with other entities. Some utilities and facility owners have developed specialized in-house computer software to perform the required tracking as self-developed software can cater to the preferences of the user. On the downside, the development and upkeep of such programs can be expensive and time consuming. Consequently, some owners choose to purchase software specifically designed to provide this function. Such software is often made available and packaged along with other programs commonly used for protection work, such as short circuit and relay setting software.

Tracking and documentation of firmware upgrades on numerical relays is another important issue that needs to be carefully addressed. Such upgrades are often issued by manufacturers to fix “bugs” that have been uncovered in existing designs or simply to enhance operational features of the relay. When such upgrades are received, the owner needs to decide if the benefits received from the upgrade are worth the effort required to apply them. The responsibility for making such decisions should be placed within a single and centralized group in the specific organization. Upgrades that fix an operational defect should always be applied if the function in which the defect exists is used, or ever may be used, on any associated devices that exist on the system. If a firmware upgrade is applied on any one of the related devices, it is recommended that all such devices that exist on the system be similarly upgraded. This practice will promote consistency and uniformity such that confusion and possibility of errors occurring in the future will be mitigated. The records for each device should clearly indicate all firmware upgrades that have been applied. It is also important that the version of software required for keying the input settings into each relay, based on its current firmware design, should be identified and documented as part of the relay’s record.

15.13 FAULT LOCATION

Identifying the location of faults is an important process for promoting higher reliability of electric power systems. Such knowledge is especially important for faults on lines because lines extend over large geographical areas. Knowledge of the location of a permanent fault allows the utility to promptly dispatch personnel to the scene to make necessary repairs. The sooner the personnel arrive at the scene, the faster the service can be restored. Experience has shown that a significant portion of outage times are caused because of the time required in locating the failure. In addition, finding the location of

a transient fault can result in the identification and replacement of damaged power system facilities. Damages such as cracked insulators and conductors with burnt strands have often been found at the scene of a transient fault. Identification of such damage allows for the development of a replacement plan that minimized the impact on customer service and acts to prevent a likely permanent failure and customer outages in the future.

Many modern microprocessor-based relays are designed with the capability to calculate the location of faults on lines. Although the provision of this feature certainly requires some additional algorithms and data to be programmed into the relay, the required measured quantities already exist within the relay for other purposes. Fault location capability can, therefore, be provided by numerical relays at minimal additional cost. Before the availability of numerical relays, utilities relied to a large extent on calls from the public or manual patrols of the line to find the location of a fault. In cases for which fault recorder data were available, off-line comparisons of fault data and fault study results could be conducted to develop an estimate of the fault location. On account of the limited availability of fault recorder data, such analysis could only be conducted for a relatively small number of faults. Even when such analysis was possible, it often took considerable time to retrieve information from older types of fault recorders and time was also required to perform the related analysis. The fault location was often located by other means before completing the calculation.

There have been a number of different methods developed for calculating the location of faults. As previously noted, one method involves the matching of fault recorder data with short circuit study data. Unfortunately, this process is usually limited to high-voltage systems and is relatively slow. Another method involves the time measurement of traveling waves that are caused by the fault. This method is rather expensive as specialized equipment needs to be installed specifically for this function. The impedance-based fault location method is the most commonly used calculation for analytically determining the location of faults. In this method, computations are made using current and voltage values measured at one or more terminals of the line to determine the impedance from a line terminal to the fault location. When the impedance to the fault is known, the distance to the fault can be easily determined, provided the impedance along the line is uniform.

Impedance-based algorithms for fault location calculations require the fundamental components of voltage and current that exist at the terminal. These values are readily available in many numerical relays because these data are required for algorithms associated with protective functions. In order to apply the impedance-based fault location algorithms, the related phasors need to be calculated from the voltage and current measurements and the type of fault needs to be identified. A simple “reactance” algorithm can be used, which basically calculates the reactance component of the impedance that exists between the relay location and the fault. There are various sources of

error in this calculation. Some error inherent in line impedance calculations will always exist and must be accepted and recognized. Current and potential transformer errors will also exist but are relatively minor. The accuracy of the reactance calculation in the simple method is also impacted by load flow and differences in the phase angle of the currents that are flowing toward the fault. To improve accuracy, algorithms have been developed, which refine the simple reactance method to account for load flow and angle differences. To apply such algorithms, some additional information needs to be provided to the relay. Prefault information is used by the relay to determine line loading and information on the equivalent source impedance at both ends of the line provides the required phase angle data. More accurate calculations can also be made if information on current and voltage from both line terminals is simultaneously available for the calculations.

Most modern numerical relays include the capability for calculating and displaying the distance to the fault. The calculated fault location is displayed in terms of miles to the fault from the associated relay location. To derive this value, some additional data must be provided to the relay with regard to the line impedance and the line length. The distance to the fault information is usually displayed on the relay and is sent to the communication port of the relay, from which it can be transmitted to interested personnel such as system operators and protection engineers.

The usefulness and value of fault location information depend to a significant degree on the nature of the power system on which it is applied. The value of fault location information on distribution systems is less than that for transmission systems. For instance, the impedance of distribution lines tends not to be homogeneous on account of the changes in wire size and spacing along the line. Distribution circuits also tend to split up into various directions and often contain three-phase and single-phase taps that connect to the main portion of the line. Because of these characteristics of distribution lines, practical use of the output of fault location algorithms on such systems is rather limited. With the availability of a good picture of the line topology and the impedance of line sections, systems have been developed in which fault location information can be used on distribution systems to at least narrow down possible locations of the fault. Transmission lines tend to have homogeneous impedance profiles and relatively few, if any, taps. Consequently, fault location data can be used more practically on transmission lines. However, for obvious reasons, fault location data have more value on power system networks that contain relatively long lines located in areas that are sparsely populated and difficult to access.

Experience has shown that fault location information is used by utilities as part of their operating practices and has proven to be a valuable addition to the tools available for lowering outage time. Some care must be taken so that the indicated locations are not always blindly accepted as accurate without question. Some sources of error certainly exist that can make the calculated

distance values relatively useless. Improper identification of the fault type is one source of such error. Evolving faults can often lead to these types of improper identification. Faults of very short duration can also result in significant error in the distance calculation. The more cycles of fault data that are available result in a more accurate calculation. Off-line analysis tools are available to help verify calculated results when questions arise. Protection engineers are often required to provide assistance in conducting off-line analysis. In fact, the protection engineer should be familiar with the manner in which various algorithms perform the calculation along with an understanding of the type of algorithm used in the devices utilized. Although errors are possible, utilities have found that the value of the higher percentage of relatively accurate indications far outweigh any confusion caused by the few inaccurate indications. Further refinements in fault location methodologies and the manner in which the information is applied to power system operations can only add to the value of this supplementary capability provided by microprocessor-based relays.

15.14 POWER SYSTEM AUTOMATION

Power system automation refers to the use of intelligent devices for making decisions and implementing related action to automatically control the operation of power systems. The automated processes for making control decisions lie within the computers, intelligent instrumentation, and control devices. Protective devices are a part of the array of electronic intelligent devices that are used in automation systems, and, therefore, protection engineers should develop a familiarity and a working knowledge of the manner in which these systems function.

In early years, a majority of power system control was accomplished manually at the site of switchgear and control devices. Major substations were often manned on a continuous basis. Substation personnel would report and record meter readings at the substation and perform switching as required. Subsequently, developments in communication systems and electronic control devices led to the installation of supervisory control and data acquisition systems. With such systems, meter readings were automatically forwarded to central system operating offices over communication systems, which generally consisted of telephone circuits. Such systems also provided system operators with control of substation devices, which could be operated remotely. Switching of devices that existed out on lines remained to be accomplished manually in most cases. With the development and implementation of microprocessor-based intelligent devices, it became possible to automate many of the decisions and switching commands made by system operators. Such application is known as power system automation. The power of automation systems lies in their ability to simultaneously process huge amounts of data and to initiate immediate action. This allows for outage

times to be reduced and for utilities to delay or forego expenditures for capital equipment. A number of applications of power system automation have been previously discussed in this book. Several of such systems include:

1. Centralized load shedding schemes to combat underfrequency or undervoltage conditions
2. Automatic changing of relay settings for different loading or system configuration conditions
3. Wide area controls to help prevent angular instability

Various other types of automation systems have been proposed and implemented on power systems. Systems that automatically resectionalize distribution and subtransmission lines are used to quickly restore as much load as possible following a line failure. Automatic meter reading systems have been installed by many utilities. Such systems allow the utility to eliminate the need to manually read meters, provide the utility with more precise load data, and allow customers to take advantage of various types of rate incentives. Automation is a very wide field that goes beyond the scope of this book. As indicated, power system automation involves the interconnection of a variety of intelligent control devices, data acquisition devices, and digital computers that are programmed to process the data and initiate related control commands. Digital devices are required to receive the commands and to initiate signals to operate switching and control devices. Communications obviously play an important part in transmitting commands, data, and status signals between the multitude of widely dispersed intelligent devices and computer systems. It is important that all engineers involved with power system controls be familiar with the languages and equipment used for the associated communication systems. This is an area which is often foreign to power engineers who have not studied or worked within the communications field. At the substation level, a communication processor is used as a hub to support multiple and simultaneous communication links. The processor also performs data acquisition and control of other substation intelligent devices. Digital relaying will have connections to the communication processor. Access to the relay to send and receive data is accomplished through the processor. This allows for the settings to be changed and the relay to be interrogated from remote locations. It is critical that foolproof safeguards are put in place to assure the highest level of security for such communication systems as considerable harm can be done to the power system if access to the system is penetrated by outside parties.

A variety of communication protocols are available for use in communication systems used for power system automation. A communication protocol is a formal set of conventions governing the format and relative timing of message exchange between two communication terminals. Common protocols that are in use include the following:

1. ASCII—A simple but relatively slow protocol that converts with ease to readable characters and numbers.
2. MODBUS—A trademarked system that emulates the transfer of register data between programmable logic controllers. This protocol has been used extensively in industrial systems with some application at power substations.
3. MODBUS PLUS—A medium speed network that is trademarked and is basically an extension of the MODBUS protocol.
4. UCA/MMS—A protocol designed by a cooperative effort of North American utilities, vendors, and consultants to provide uniformity such that communication between intelligent devices regardless of manufacturer is facilitated. It is intended that this protocol will eventually satisfy most requirements of all types of power system equipment.

In addition to protocols, there are various arrangements for the communication systems. Communication networks can be created by either a direct or multidrop connection. In a direct connection, two devices are connected directly to one another through a metallic, wireless, or fiber communication media. With a direct connection, constant control of the connection is possible and each device is always aware of the device to which it is connected. A system that is arranged with many direct connections from one device to many others is called a “star” connection. Such a connection allows communications with many intelligent devices simultaneously. Protective relays are typically connected to a communication processor in a star arrangement. Star networks are also used for most Ethernet systems with a router, hub, or switch as the center of the network. Several intelligent devices can be connected in a ring or bus arrangement to create a multidrop network topology. Only one device can speak at a time in a multidrop network and all associated devices must speak the same language, use the same baud rate, and share a common physical connection. A broadcast multidrop allows for one-sided sending of a message from a host to a multitude of receivers. This is like broadcasting a message over a radio station—many can receive the message but responses are not possible. In multidrop networks, at any time, only one device has permission to speak. If control over the device that currently has permission to send a message is lost, communication is lost between all devices in the network.

As technology improves and costs come down, power system automation systems will be applied at an increased rate. As the benefits received from such systems are seen to more clearly exceed the investment required, utilities will become less reluctant to move toward higher levels of automation. The designs of the automation systems will also change considerably as new technologies, such as wireless communications, are developed, proven feasible, and applied. As indicated, protective devices will need to be integrated into the designs because these devices play an important role in automation systems. It is important that the designs for such automation systems, no

matter what form they may take, always allow the protective device to carry out its primary protection function in an independent manner. This requires that the protective devices be provided with independent interfaces for the measured quantities and for output commands.

15.15 PRACTICAL OBSERVATIONS—MICROPROCESSOR RELAY APPLICATION

One only needs to scan through trade magazines and vendor catalogs or talk to utility protection personnel to conclude that microprocessor-based protection has risen to the ‘technology of choice’ with regard to power system protection. This is a generally recognized fact by all involved in this area and is certainly not a startling revelation. It is of interest to note, however, that acceptance of numerical relays did not occur overnight. As a practicing utility protection engineer, I can affirm that, at the onset of microprocessor relays being made available for application, considerable apprehension existed concerning their acceptance. Power system protection has always been ingrained with tradition along with a general reluctance for trying something new. Older engineers who were generally in a position to make decisions were not anxious to take on personal risk or to be exposed to learning a new technology. In addition, conflicting views often exist within utilities when proposals are made to change designs. Such change often requires some research and development time. Company functions with responsibility for approving expenditures require cost versus benefit justification before approving projects. Such justification is sometimes difficult to identify when dealing with applications of new technologies. Thus, there were many acceptance barriers that hindered the initial attempts to apply microprocessor-based protection. In addition, initial experience with microprocessor relays was not always good and, in some cases, alarming. Relays were sometimes found in a shutdown mode with difficulty to place them back in service. Cases were reported in which breakers tripped many hundreds of times in a short span of time without any evidence of a fault. Setting software sometimes caused frustration when it would not interface with the associated relay. Multitudes of firmware upgrades, frequent model changes, and instruction manuals that sometimes seemed to be written in a foreign language did not help the cause. Nevertheless, the technology prevailed mainly because it represented a better way to provide power system protection. It is a tribute to everyone working in the industry who had this foresight, stuck by their convictions, and ultimately brought the science of power system protection to a new level. It is critical that the process of using technology for the benefit of society continues—for this is the key to improve the world in which we live. An important ingredient of this process is well-educated scientists and engineers: professionals who strive to develop an instinct for the science in which they are involved: professionals who are not afraid to be innovative, to take

calculated risks, to be open to new ideas, and to always respect the work and ideas that are produced by others. No engineer should ever feel that his work is too insignificant or routine to make a difference, as this is never the case.

One truly hopes that some of the principles of system protection, the technical fundamentals, the practical examples, and the personal insights that are provided in this text serve to provide at least little value and inspiration to those working in the most challenging and exciting field of power system protection.

BIBLIOGRAPHY

- Costello, David, *Understanding and Analyzing Event Report Information*, Schweitzer Engineering Laboratories, Inc., Pullman, Washington.
- Dolezilek, David J., *Power System Automation*, Schweitzer Engineering Laboratories, Inc., Pullman, Washington.
- Elmore Walter A., *Protective Relaying Theory and Applications*, 2nd ed, Revised and Expanded, Marcel Dekker, Inc. 2004.
- Escobedo, David Sanchez, E.A. Ramirez, O.A.M. Villanueva, and H.J.A. Ferrer, *Multifunction Relays and Protection Logic Processors in Distribution Substation Applications*, Schweitzer Engineering Laboratories, S.A. de C.V. Nonterrey, N.L., Mexico.
- IEEE Tutorial Course, *Advancements in Microprocessor Based Protection and Communication*, IEEE Operations Center.
- Klaus-Peter Brand, Volker Lohmann, Wolfgang Wimmer, *Substation Automation Handbook*, Utility Automation Consulting Lohmann, 2003.
- Kupholdt, Tony R., *Lessons in Electric Circuits*, Vol. 4, Digital, January 18, 2006.
- Mooney, Joe, *Microprocessor Based Transmission Line Relay Applications*, Schweitzer Engineering Laboratories, Inc., Pullman, Washington.
- Young, Mike, John Horak, *Commissioning Numerical Relays*, Basler Electric Company.
- Zimmerman, Karl, David Costello, *Impedance-Based Fault Location Experience*, Schweitzer Engineering Laboratories, Inc., Pullman, Washington.

Problems

These practical problems, developed over many years from actual experience, provide the opportunity to apply the material in the book by practicing the basic techniques. Problems involving application choices are generally so subjective that I have avoided them whenever possible. Each problem has a message to be unlocked with a reasonable minimum of labor—that is, with a good RH factor, where R denotes relative minimum labor and H denotes high educational value.

CHAPTER 2

- 2.1 A wye-connected generator has a nameplate rating of 200 MVA, 20 kV, and its subtransient reactance (X''_d) is 1.2 pu. Determine its reactance in ohms.
- 2.2 The generator of Problem 2.1 is connected in a power system where the base is specified as 100 MVA, 13.8 kV. What is the generator reactance (X''_d) in per unit on this system base?
- 2.3 Convert the per-unit answer calculated in Problem 2.2 to ohms. Does this match the value determined in Problem 2.1?
- 2.4 Three 5 MVA single-phase transformers, each rated 8:1.39 kV, have a leakage impedance of 6%. These can be connected in a number of different ways to supply three identical 5 Ω resistive loads. Various transformer and load connections are outlined in Table P2.4. Complete the table columns. Use a three-phase base of 15 MVA.

TABLE P2.4

Case No.	Transformer Connection		Load Connection to Secondary	Line-to-Line Base kV		Total Z as Viewed from the High Side	
	Primary	Secondary		HV	LV	Per unit	Ω
1	Wye	Wye	Wye				
2	Wye	Wye	Delta				
3	Wye	Delta	Wye				
4	Wye	Delta	Wye				
5	Delta	Wye	Wye				
6	Delta	Wye	Delta				
7	Delta	Delta	Wye				
8	Delta	Delta	Delta				

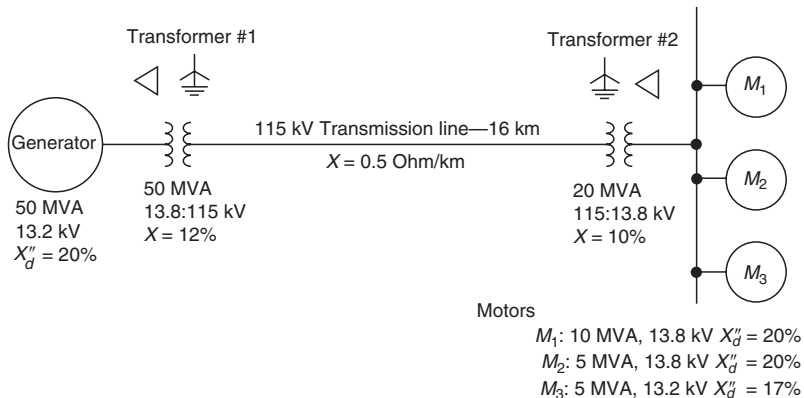

FIGURE P2.5

- 2.5** A three-phase generator feeds three large synchronous motors over a 16 km, 115 kV transmission line, through a transformer bank, as shown in Figure P2.5. Draw an equivalent single-line reactance diagram with all reactances indicated in per unit of a 100 MVA, 13.8, or 115 kV base.
- 2.6** In the system of Problem 2.5, it is desired to maintain the voltage at the motor bus of $1.0 \angle 0^\circ$ per unit. The three motors are operating at full rating and 90% pf.
- Determine the voltage required at the generator terminals assuming that there is no voltage regulating taps or similar equipment in this system.
 - What is the voltage required behind the subtransient reactance?
- 2.7** The percent impedance of a transformer is typically determined by a short circuit test. In such a test, the secondary of the transformer is shorted and the voltage on the primary is increased until rated current flows in the transformer windings. The applied voltage that produces rated current divided by the rated voltage of the transformer is equal to the per-unit impedance of the transformer.

A short circuit test on a 150 KVA, 7200–240 V transformer provides the following results:

Primary voltage at 20.8 primary amperes = 208.8 V

- Determine the %Z of the transformer.
- Calculate the ohmic impedance of the transformer in primary and secondary terms.

- c. How much current would flow in the transformer if its secondary would become shorted during normal operating conditions? (Consider source impedance to be zero.)

CHAPTER 3

- 3.1 Four boxes represent an AC generator, reactor, resistor, and capacitor and are connected to a source bus XY as shown in Figure P3.1. From the circuit and phasor diagrams, identify each box.
- 3.2 Two transformer banks are connected to a common bus as shown in Figure P3.2. What are the phase relations between the voltages V_{AN} and $V_{A'N'}$; V_{BN} and $V_{B'N'}$, V_{CN} and $V_{C'N'}$?
- 3.3 Reconnect transformer bank 2 of Problem 3.2 with the left windings in wye instead of delta, and the right windings in delta instead of wye so that V_{AN} and $V_{A'N'}$ are in phase, V_i and $V_{B'N'}$ are in phase, and V_{CN} and $V_{C'N'}$ are in phase.
- 3.4 The power transformer connections shown in Figure P3.3 are non-standard and quite unusual with today's standardization. However, this connection provides an excellent exercise in understanding phasors, polarity, and directional sensing relay connections.

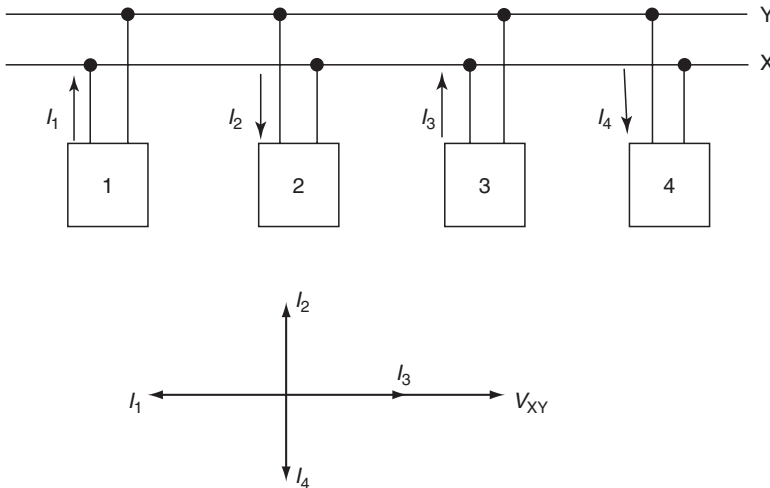

FIGURE P3.1

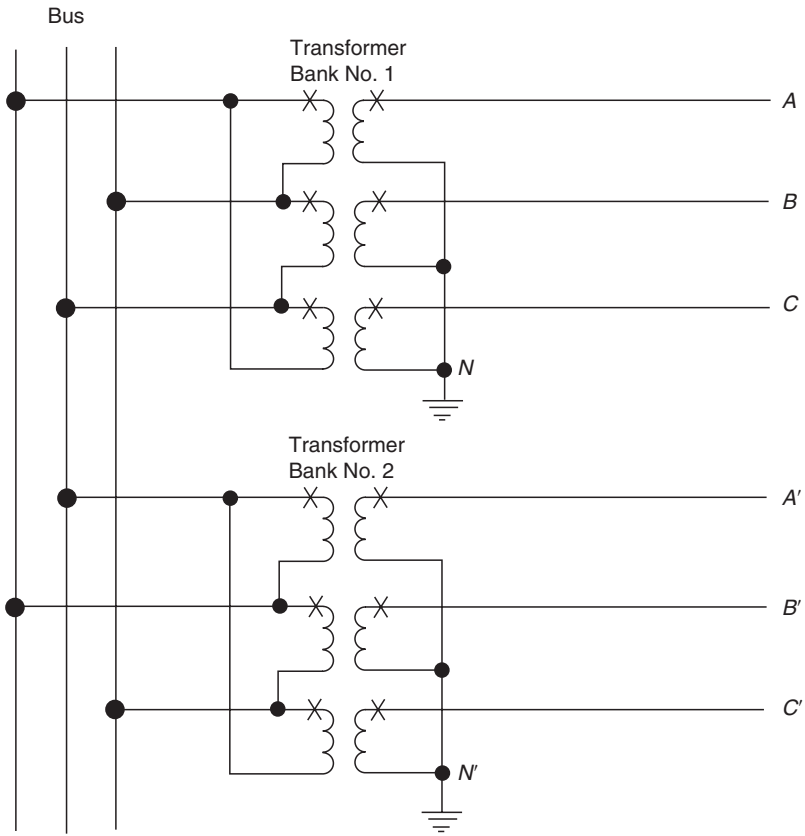

FIGURE P3.2

Connect the three-directional phase relays *A*, *B*, *C* to line-side CTs and bus-side VTs for proper operation for phase faults out on the line. Use the 90° - 60° connection. Each directional relay has maximum torque when the applied current leads the applied voltage by 30° . The auxiliary VTs should be connected to provide the relays with equivalent line-side voltages.

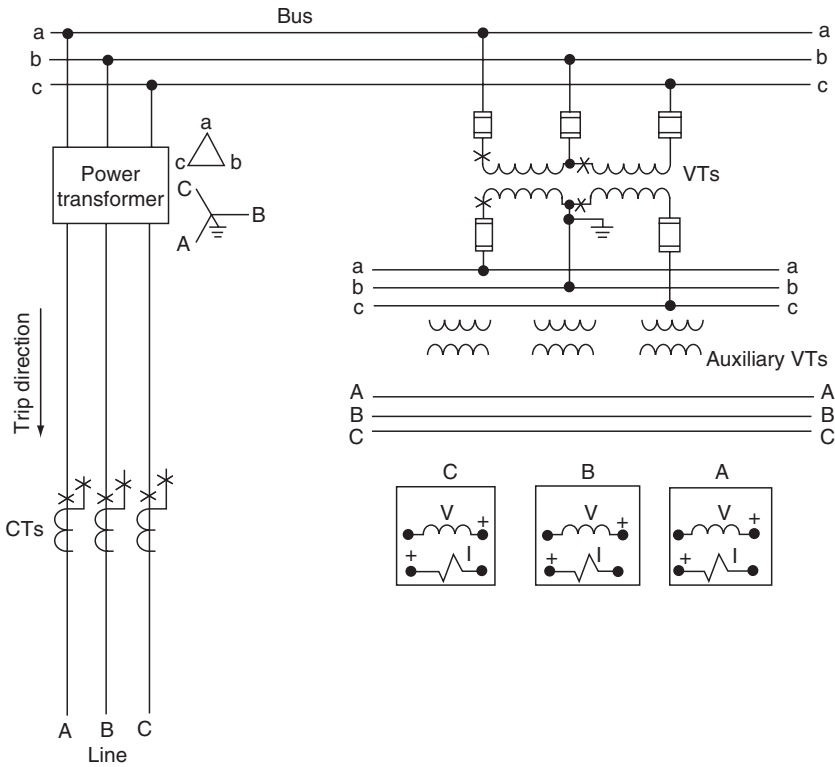

FIGURE P3.3

CHAPTER 4

- 4.1 The per-unit currents for a phase-*a*-to-ground fault are shown in the diagram of Figure P4.1. Assume that the system is reactive with all resistances neglected and that the generator(s) are operating at $j = 1.0$ per-unit voltage.

Draw the positive, negative, and zero sequence diagrams and describe the system that must exist to produce the current flow as shown.

- 4.2 For the system shown in Figure P4.2
- Determine the source and equivalent star reactances of the transformer on a 30 MVA base.
 - Set up the positive, negative, and zero sequence networks. There are no fault sources in the 13.8 and 6.9 kV systems. Reduce these

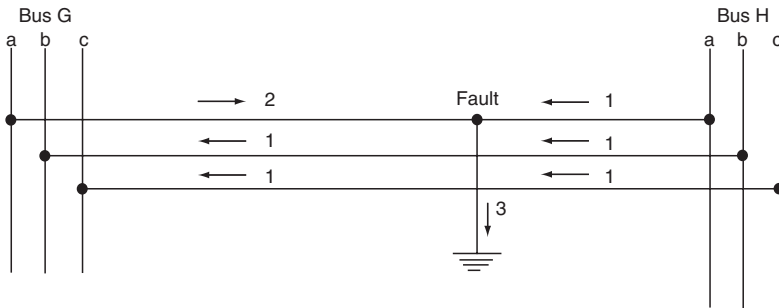

FIGURE P4.1

- networks to single-sequence reactances for faults on the 13.8 kV side.
- Calculate a three-phase fault at the 13.8 kV terminals of the transformer.
 - Calculate a single-phase-to-ground fault at the 13.8 kV transformer terminals.
 - For the fault of part d, determine the phase-to-neutral voltages at the fault.
 - For the fault of part d, determine the phase currents and the phase-to-neutral voltages on the 115 kV side.
 - For the fault of part d, determine the current flowing in the delta winding of the transformer in per unit and amperes.
 - Make an ampere-turn check for the fault currents flowing in the 115, 13.8, and 6.9 kV windings of the transformer.

4.3 For the system shown in [Figure P4.3](#)

- Determine the current flowing to the load. Assume that the generators of the equivalent source behind the 13.8 kV bus are operating at 1 per-unit voltage at 0° .

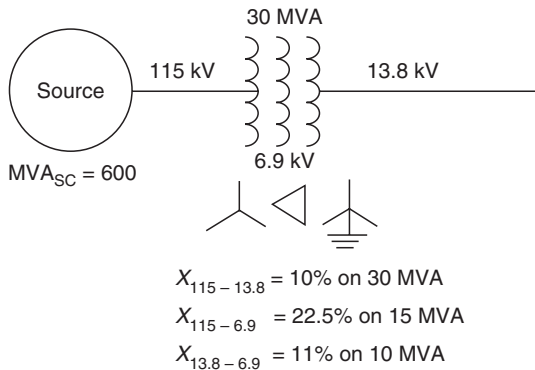

FIGURE P4.2

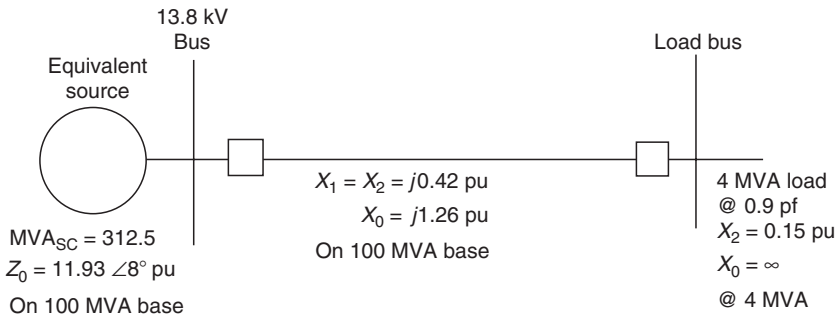

FIGURE P4.3

- b. Calculate the voltage at the load bus.
 - c. Calculate the fault current for a solid phase-*a*-to-ground fault at the load bus. Neglect load for this part.
 - d. Calculate the currents flowing in the line when an open circuit occurs in the line just at the load bus. Assume that phase *a* opens while carrying the load as indicated.
 - e. Calculate the currents flowing when the open phase of a conductor of part d falls to ground on the source side of the open. Assume a solid fault.
 - f. Repeat part e but for the case when the opened conductor falls to ground on the load side.
- 4.4** Repeat the example of [Section 4.14](#) for a solid phase-to-ground fault on the 161 kV terminals of the autotransformer. Compare the directions of the currents in the bank neutral and the tertiary with those for the fault on the 345 kV side.

CHAPTER 5

- 5.1** A 13.8 kV feeder circuit breaker has a 600:5 multiratio current transformer with characteristics as shown in [Figure 5.11](#). The maximum load on the feeder is 80 A primary. Phase time inverse over-current relays are connected to the CT secondaries. The relay burden is 3.2 VA at the tap values selected, and the lead burden is 0.38 Ω.
- a. If the 100:5 CT ratio is used, then a relay tap of 5 A is required in order for the relay pickup to be 125% above the maximum load. With these, determine the minimum primary current to just operate the relays.
 - b. For the selection of part a what is the approximate maximum symmetrical fault current for which the CTs will not saturate (use the ANSI/IEEE knee point)?
 - c. If the 200:5 CT ratio is used so that the 2.5 A relay tap can be used, determine the minimum primary current to just operate the relays.

- d. Repeat part b for the selection of part c.
- e. Which of these two CT and relay selections would you recommend?
- 5.2** Determine the minimum CT ratio that might be used with a 0.5–2.5 A ground relay with an instantaneous trip unit set at 10 A. The total ground relay burden is 285 VA at 10 A. See Figure 5.10 for CT characteristics.
- 5.3** A circuit has 800:5 wound-type CTs with characteristics as shown in Figure 5.7. The maximum symmetrical fault for which the associated relays are to operate is 15,200 A. Approximately what will be the error in percent if the total connected burden is 2.0 Ω ? What will it be if it is 4.0 Ω ?
- 5.4** The feeder of Problem 5.1 has a ground relay connected in the CT circuit which has a burden of 4.0 VA at tap value. The taps available are 0.5, 0.6, 0.8, 1.0, 1.5, 2.0, and 2.5, which represent the minimum pickup current. What is the maximum sensitivity that can be obtained in primary amperes for a phase-*a*-to-round fault? Assume that $I_b = I_c = 0$ for the fault and that the phase relay burden is 0.032 Ω if 50:5 CT ratio is used, 0.128 Ω with 100:5 tap, 0.261 Ω with 150:5 tap, and 0.512 Ω with 200:5 tap.
- 5.5** Phase and ground relays are connected to a set of voltage transformers (VTs) as shown in Figure P5.5. The secondary winding voltages are 69.5 V for the phase relays and 120 V for the ground relays. The

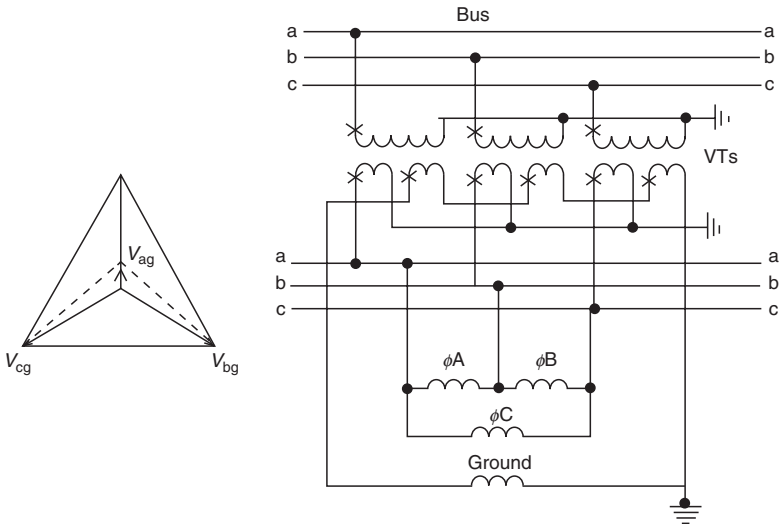

FIGURE P5.5

equivalent line-to-neutral burden of the phase relays is 25 VA resistive each phase at 69.5 V. The burden of the ground relays is 15 VA, 120 V at 25° leading pf angle.

- a. Calculate the total burden on each of three voltage transformers during a phase-*a*-to-ground fault, which reduces the phase *a* voltage to 0.15 per unit.
- b. What is the minimum-capacity voltage transformer that can be used for this application?

CHAPTER 7

- 7.1 Phase *a* of a three-phase 4.16 kV ungrounded system is solidly grounded. For this fault, calculate the magnitude of the positive, negative, and zero sequence voltages at the fault. Explain your answers with reference to the sequence networks and interconnections used to calculate line-to-ground faults on three-phase systems.
- 7.2 An ungrounded 4.16 kV system has a capacitance to ground of 0.4 μF per phase. In this system:
 - a. Calculate the normal charging current in amperes per phase.
 - b. Calculate the fault current for a phase-*a*-to-ground fault.
 - c. Will this fault current operate a ground overcurrent relay set at 0.5 A pickup and connected to 100:5 current transformer or a ground sensor connected to a toroidal type CT with a primary pickup of 5 A?
 - d. It has been decided to ground this system with a zig-zag transformer and neutral resistor. The source to the 4.16 kV bus has $X_1 = 10\%$ on 5000 kVA. If in this system X_1 is 2.4% on the zig-zag bank rating, what is the kVA of the zig-zag bank?
 - e. In order to limit the overvoltage on the unfaulted phases to a maximum of 250% for possible restriking ground faults, it is necessary that

$$\frac{X_0}{X_1} \leq 20 \quad \text{and} \quad \frac{R_0}{X_0} \geq 2.0.$$

This requires a zig-zag transformer reactance of 6.67% and a ground resistor of $0.292 + j0.124$ per unit, all on the zig-zag transformer rating. Verify that these ratios requirements have been met.

- f. Calculate the solid phase-*a*-to-ground fault current in the 4.16 kV system with the zig-zag transformer and resistor grounding.
 - g. Provide specifications for purchasing the zig-zag transformer and resistor.
 - h. Will the relays in part c operate for ground faults of part f?
- 7.3 Verify that the unusual connection of voltage transformers shown in [Figure P7.3](#) provides zero sequence voltage during a ground fault on

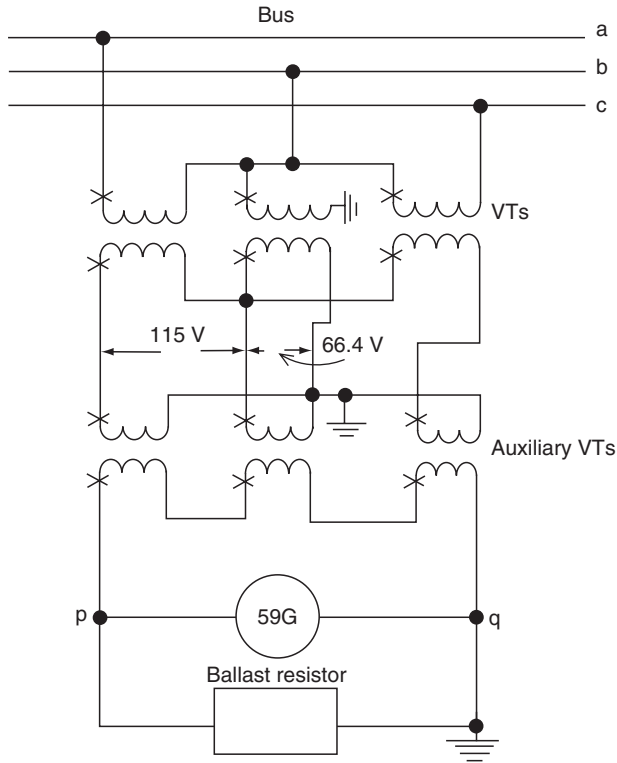

FIGURE P7.3

an ungrounded system for operation of the overvoltage relay 59G. (This connection used by a large power system for ground detection on ungrounded systems supplied from delta tertiary.)

Open-delta connected VTs are used for three-phase voltage, and the desire was to use these with minimum additions. Figure 7.5a connections using three auxiliary VTs in broken delta had a tendency in their system to go into ferro-resonance, probably because the resistor was not effective with the high leakage impedance of the auxiliaries. The scheme shown was evolved using the two existing VTs and adding a VT-connected phase to ground. This added VT is either a 60 Hz rated twice line-to-line voltage unit or a 25 Hz unit rated line-to-line so that they operate low on the saturation curve. No ferro-resonance has been encountered with this scheme.

- 7.4 a.** To limit ground faults, a reactor is to be connected in the grounded neutral of the 13.8 kV winding of the transformer (Figure P7.4). Calculate the value of the reactor in ohms required to limit the solid single-phase-to-ground current on the 13.8 kV side to 4000 A.

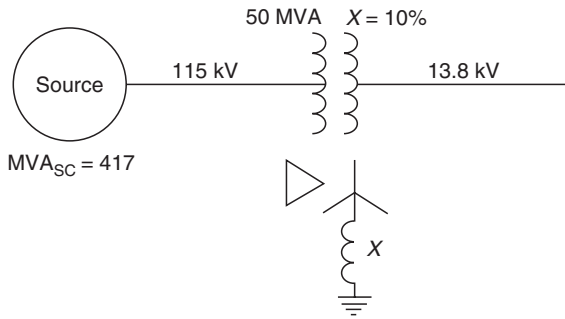

FIGURE P7.4

- b. What percentage reduction would this represent if the wye winding were solidly grounded instead of being grounded through the reactor?
- c. Repeat part a except using a resistor instead of a reactor. Determine the resistor value in ohms.

7.5 The directional ground relay has been connected (Figure P7.5) for operation on ground faults out on the line. The relay has maximum

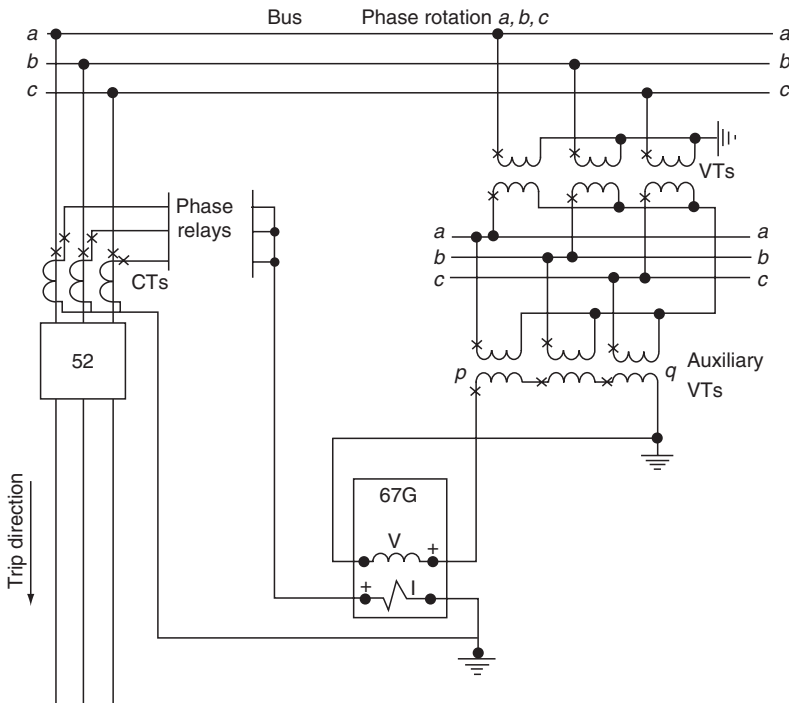

FIGURE P7.5

torque when the current lags the voltage by 60° , with the relative instantaneous polarities as shown.

- Are the connections correct? Check by assuming a line-to-ground fault in the tripping direction. Make any corrections as required.
- With the correct connections of a, field checks are to be made to verify the connections. Assuming 100% pf load, determine whether these checks provide relay-directional unit operation or not. Support your answer with a phasor diagram: Test A—Short phase c current transformer and open the secondary lead. Open phase a voltage transformer lead and short the secondary winding of that transformer. Restore connections after test; Test B—Short phase b current transformer and open the secondary lead. Open phase c voltage transformer lead and short the secondary winding of that transformer. Restore connections after test.

CHAPTER 8

- 8.1** Three 21,875 kVA, 13.8 kV generators with $X''_d = 13.9\%$ are connected to individual buses, from which various loads are supplied. These buses are connected to another bus through 0.25Ω reactors as shown in Figure P8.1. The generators are all ungrounded. In this system:
- Calculate a three-phase fault at the terminals of one of the generators.

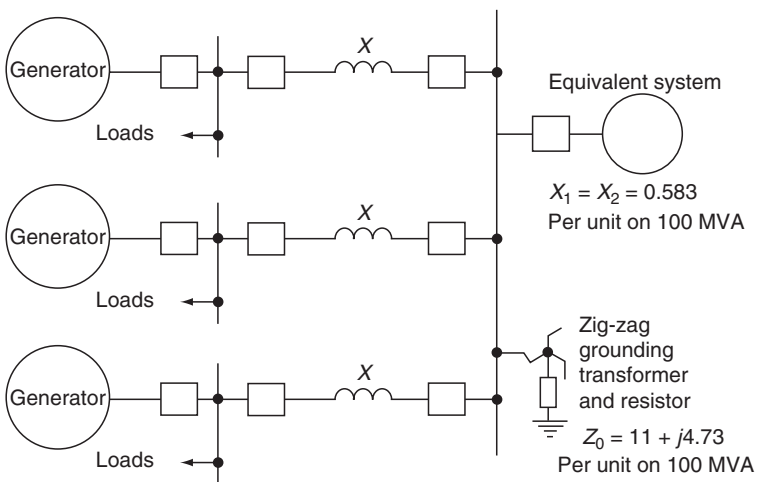

FIGURE P8.1

- b. Choose a current transformer ratio for differential relays to protect the generators. If the generator differential relays have a minimum pickup of 0.14 A, how many times pickup does the three-phase fault provide?
- c. Calculate a single-phase-to-ground fault at the terminals of one of the generators.
- d. Will this ground fault operate the generator differential relays? If so, how many times pickup will the ground fault provide?
- 8.2** The unit generator shown in Figure P8.2 has the following capacitance-to-ground values in microfarads per phase:

Generator-surge capacitors	0.25
Generator-to-transformer leads	0.004
Power transformer low-voltage windings	0.03
Station-service-transformer high-voltage windings	0.004
Voltage-transformer windings	0.0005

The ground resistor R has a 64.14 kW rating at 138 V.

- a. Determine the fault current magnitude for a single-line-to-ground fault between the generator and the power transformer.
- b. Determine the three-phase fault current magnitude for a fault between the generator and the power transformer.
- c. Choose a CT ratio for the generator differential protection. Compare the fault currents of parts a and b with the generator relay pick-up value of 0.15 A.

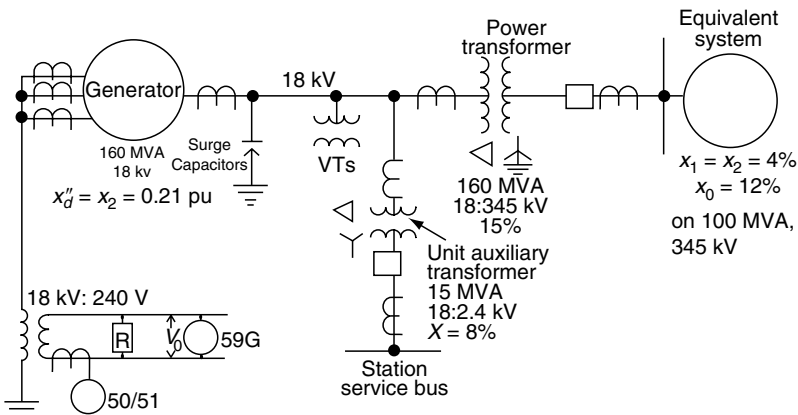

FIGURE P8.2

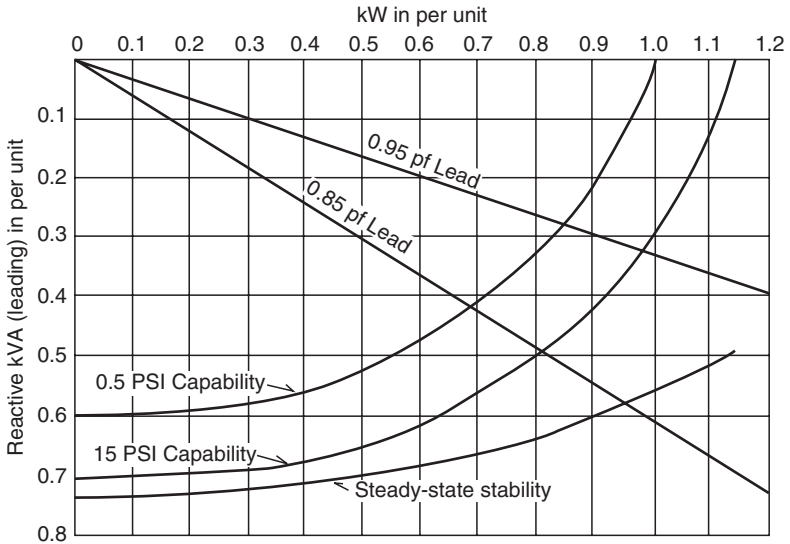

FIGURE P8.3

- d. How much voltage is available to operate an overvoltage relay 59G when connected across the grounding resistor? What is the multiple of pickup if 59G minimum operating value is 5.4 V.
 - e. How much current flows through the resistor? Select a CT and suggested overcurrent pickup values for the 50/51 relay.
- 8.3** The per-unit kVA capability and steady-state stability curves at rated terminal voltage for a 50 MVA, 13.2 kV, 60 Hz generator are shown in Figure P8.3. The current transformers used are 3000:5. For loss-of-excitation protection:
- a. Translate the steady-state stability limit to a per-unit $R-X$ diagram for a terminal voltage of 1.0 per unit.
 - b. Translate the 15 psi capability curve to a per-unit $R-X$ diagram for a terminal voltage of 1.0 per unit.
 - c. With these limits plotted on an $R-X$ diagram, draw a distance relay offset mho circle to provide protection for low or loss of excitation on this machine.
 - d. For the relay mho circle selected in part c, determine the per-unit offset (distance of the circle center from the $R-X$ origin) and the per-unit circle radius. Translate these values to relay ohms for setting a loss-of-excitation relay, $R_c = 3000:5$. $R_v = 120$.
- 8.4** A 100 MW generator is connected at the end of a radial 32 mile, 138 kV line. The 138 kV bus at which the line terminates is regulated to maintain a constant bus voltage of 138 kV. The impedance of the 138 kV line is $0.25 + j0.80 \Omega/\text{mile}$. Desired operation is such that

100 MW and 20 MVAR are to be delivered from the line into the bus at the 138 kV bus location. (This represents a lagging angle for current flow from the line into the bus.) There is no other load on the line. It is the policy of the utility to limit the operating voltage on its lines to 6% above nominal. As such, the overvoltage relay connected on the 138 kV side of the generator unit transformer at the generator location is set at 121.9 V. (115 V base)

- For the above operating condition, calculate the voltage on the 138 kV side of the generator unit transformer along with the MW and MVAR flow at this location. What are the MW and MVAR losses in the line?
- Based on the calculation made in (a), will the desired operation be possible if the overvoltage relay is connected to trip the generator?
- If operation is changed such that 100 MW and 0 MVAR is to be delivered at the 138 kV bus, will the overvoltage relay setting be exceeded?

CHAPTER 9

9.1 Assume for this problem that the 69 kV system (Figure P9.1) is open and make the following calculation:

- Calculate the fault current in the three phases for a solid phase-*a*-to-ground fault on the 69 kV terminals.
- Calculate the three-phase voltages existing at the fault.
- For this 69 kV ground fault, determine the currents flowing in the 13.8 kV system.

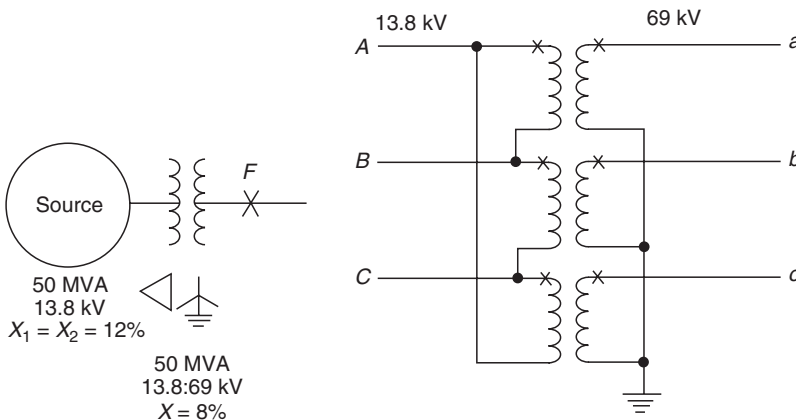

FIGURE P9.1

- d. What are the voltages for the three phases at the 13.8 kV transformer terminals for the 69 kV fault?
 - e. Compare the current and voltage phasors on the two sides of the bank for the 69 kV ground fault.
- 9.2** For the transformer bank of Problem 9.1, assume that phases *A*, *B*, *C* on the 13.8 kV side have 3000:5 CTs with taps at 1500, 2000, 2200, and 2500 A, and that the 69 kV circuits *a*, *b*, *c* have 600:5 multiratio CTs with taps, as indicated in Figure 5.10.
- a. Show the three-phase connections for transformer differential relays to protect this bank.
 - b. Select suitable 69 kV and 13.8 kV CT ratios for this transformer differential application.
 - c. If the differential relay has taps of 4, 5, 6, and 8, select two taps to be used with the CT ratios selected in part b so that the percent mismatch is less than 10%.
 - d. With this application and setting, how much current can flow to operate the differential relay(s) if the phase-*a*-to-ground fault of Problem 9.1 part a is within the differential zone? How many of the three relays operate for this ground fault?
- 9.3** The transformer bank (Figure P9.3) shown connected between the 13.8 and 2.4 kV buses, consists of three single-phase units, each rated 1000 kVA 13.8:2.4–1.39 kV.

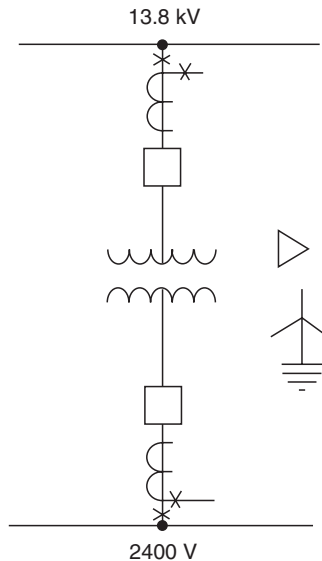

FIGURE P9.3

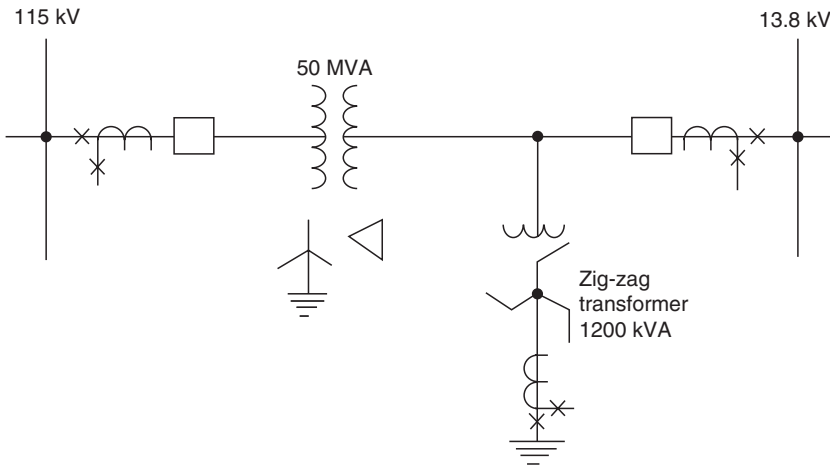

FIGURE P9.4

- a. Connect a two-restraint type differential relay for protection of the transformer bank.
 - b. Select proper current transformer ratios and relay taps. Assume that the differential relay has ratio adjusting taps of 5:5 to 5:10 with the ratios of 1, 1.1, 1.3, 1.5, 1.6, 1.8, and 2.0. The CTs on the 13.8 kV breaker are 200:5 with 150, 100, and 50:5 taps, and on the 2.4 kV breaker; 2000/1500/1000/500:5 CTs.
 - c. If one of the single-phase transformers is damaged, can service be continued with the remaining two banks? If so, show the connections, including any modifications required for the differential relaying.
 - d. What is the maximum three-phase load that can be carried with any temporary connections?
- 9.4** A 50 MVA transformer bank (Figure P9.4), wye-grounded to a 115 kV bus, and delta to a 13.8 kV bus, supplies power to the 13.8 kV system. Transformer breakers are available on both sides of the bank with 300:5 (115 kV side) and 2200:5 (13.8 kV side) current transformers. To ground the 13.8 kV system, a 1200 kVA zig-zag transformer has been connected between the power transformer and the 13.8 kV bus and within the differential zone. For this arrangement as shown:
- a. Connect three two-restraint type transformer differential relays to protect the 50 MVA bank using the two sets of CTs on the breakers. Only these are available.
 - b. The system $X_1 = X_2$ reactance to the 13.8 kV bus is 13% on 50 MVA, and the zig-zag bank reactance is 6% on its rating base. Calculate the current for a solid single-phase-to-ground fault on

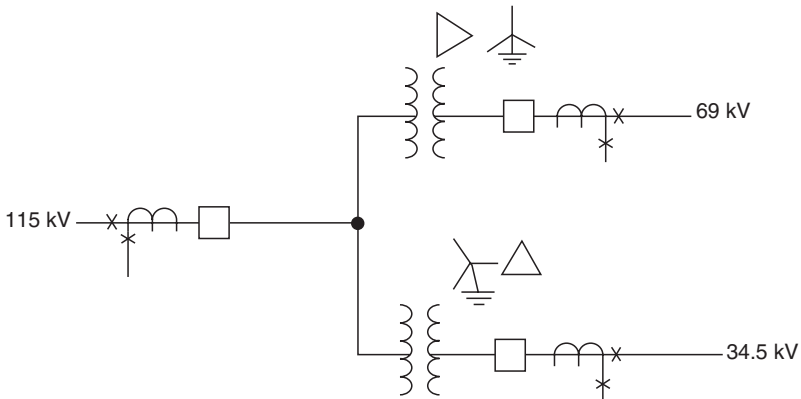

FIGURE P9.5

the 13.8 kV system. If the transformer differential relays have a pickup of 1.8 A, will they operate for a ground fault within the differential zone? What would you recommend for protection of the zig-zag bank?

- 9.5** Two separate transformer banks are connected as shown in Figure P9.5, without high-side breakers for economy. High-side transformer CTs are not available. The banks are connected per ANSI Standards. For this arrangement:
- Show complete three-phase connections for protecting these two transformer banks using three three-winding type transformer differential relays and the three sets of CTs shown.
 - Discuss the advantages and disadvantages of this protection compared with separate transformer differentials if separate 115 kV transformer CTs had been available.
- 9.6** For the application shown in Figure 9.12 and Figure 9.13, determine the currents that will flow in the relays for an 800 A ground fault. The neutral CT ratio is 250:5 and the line CT ratios are 1600:5. In the following determinations, choose a value of n to provide a good level of current in the 87G relay windings:
- For the ground fault external to the differential protection zone.
 - For the ground fault internal and within the differential protection zone. Assume the low-voltage feeders supply zero current to the internal fault.
- 9.7** A 1 MVA transformer bank, 13.8 kV delta, 480 V wye, solidly grounded with $X = 5.75\%$, supplies a group of induction motors. The source $X_1 = X_2$ is 0.0355 per unit on 5 MVA, 13.8 kV. The 13.8 kV, 65 A fuses are used to protect the transformer bank and the 480 V arcing faults, determine the following:
- What is the maximum possible ground-fault current at the 480 V bus?

- b. With a typical arc voltage of 150 V essentially independent of current magnitude, determine the magnitude of the arcing fault at the 480 V bus.
- c. What is the magnitude of this arcing fault on the 13.8 kV primary?
- d. Estimate the total clearing time for the 13.8 kV, 65 A fuses used in the primary supply to the bank for the 480 V arcing fault. The total clearing time for these fuses is as follows:

150	500
175	175
200	115
250	40
300	20
350	9
400	6

- 9.8 A 1200 kvar capacitor bank is to be connected on a 12.47 kV distribution line. The bank will be connected wye-grounded and will be made up of capacitor units rated at 20 kvar. Each phase will consist of one parallel group of capacitor units. The capacitor bank will be protected with fuses connected into each phase that supplies the bank. Ampere ratings of available fuses—10 through 100 A in 10 A increments.
 - a. How many capacitor units need to be paralleled per phase?
 - b. What size fuse should be used to protect the bank?
- 9.9 A three-phase capacitor bank is being connected on a 138 kV system. Each phase of the bank will be made up of 12 series groups with 18 units per group. The bank will be protected with a mid-tapped voltage differential relay. Base voltage supplied to the relay is 115 V. (Under normal balanced conditions, the relay measures 0 V. When an unbalance occurs, the voltage seen by the relay = per-unit unbalance \times 115 V.)
 - a. Determine the alarm setting for the voltage differential relay.
 - b. Determine the trip setting for the voltage differential relay.

CHAPTER 10

- 10.1 High-impedance voltage-differential relays are to be applied to protect a three-breaker bus, as shown in Figure 10.9. The CTs are all 600:5 multiratio type with characteristics per Figure 5.10. For this application, determine the relay-pickup setting voltage and the minimum primary-fault current for which the relays will operate. The maximum external fault is 8000 A rms. Assume that the lead resistance $R_L = 0.510 \Omega$ for the maximum resistance from any CT to the junction point.

For the particular relays applied, the pickup setting voltage is

$$V_R = 1.6k(R_S + pR_L)\frac{I_F}{N}V, \quad (10.3)$$

where 1.6 is a margin factor, k is a CT performance factor (assume $k=0.7$ for this problem), $p=1$ for three-phase faults and $p=2$ for single-phase-to-ground faults (Figure 5.9), I_F is the primary rms external maximum fault current, and N and CT ratio. R_S is the CT resistance. $p=2$ should be used to determine the value of the V_R setting. The maximum setting of the relay voltage element should not exceed 0.67 times the secondary exciting voltage of the poorest CT in the differential circuit at 10 A exciting current.

The minimum internal fault primary current to operate the relays is

$$I_{\min} = (nI_e + I_R + I_T)N \text{ primary amperes}, \quad (10.4)$$

where n is the number of circuits, I_e is the exciting current of the individual CT at the pickup voltage, I_R is the relay current at the pickup setting voltage, and I_T is the current required by a high voltage protective device across the relay coil (not shown in Figure 10.9). For this problem, assume $I_T=0.2$ A. The relay impedance and generally negligible resistance of the leads from the junction to the relay is 1700 Ω . nI_e is applicable in this problem since all three breaker CTs are the same; otherwise this is a summation of the different CT exciting currents at the V_R pickup voltage.

- 10.2** A feeder circuit is added to the bus of Problem 10.1, making a four-circuit bus. The new breaker has the same type 600:5 multiratio CTs. With this addition, the maximum external fault increases to 10,000 A rms. All other circuit values remain the same. For this change, calculate the relay-pickup setting voltage and the minimum primary-fault current for which the relays will operate.

CHAPTER 11

- 11.1** A 2850 hp, 4 kV induction motor is connected to the supply system through a 2.5 MVA transformer, 13.8:4 kV with a reactance of 5.6%. The motor full-load current is 362 A and its locked-rotor current is 1970 A. The supply system short-circuit MVA at the 13.8 kV terminals of the transformer is 431 maximum, 113 minimum, on 100 MVA base. Determine if a phase-instantaneous overcurrent relay can be applied if it is set at half the minimum fault current and twice the locked-rotor current.

- 11.2** Review the application of Problem 11.1 if a time-delayed instantaneous unit is applied and set at 1.1 times locked-rotor current.
- 11.3** Another feeder is supplied by the same source as in Problem 11.1 through a 2.5 MVA, 13.8:2.4 kV transformer with 5.88% reactance. The largest motor connected to this bank is rated at 1500 hp, 2.3 kV, with a full load current of 330 A, locked rotor current of 2213.5 A. Can an instantaneous phase overcurrent relay be applied set at half the minimum fault current and twice the locked-rotor current?
- 11.4** The same source supplies a 460 V feeder through a 2 MVA transformer, 13.8 kV:480 V transformer with 5.75% reactance. The largest motor on this feeder is 125 hp, 460 V with 90.6 A full-load, 961 A locked-rotor current. Can a phase-instantaneous overcurrent be applied if set at half the minimum fault current and twice the locked-rotor current?
- 11.5** In the system shown in Figure P11.5:
- Calculate the fault currents flowing for a solid three-phase fault on the 4160 V bus. For this problem, consider the 500 hp induction motor as one of the sources.

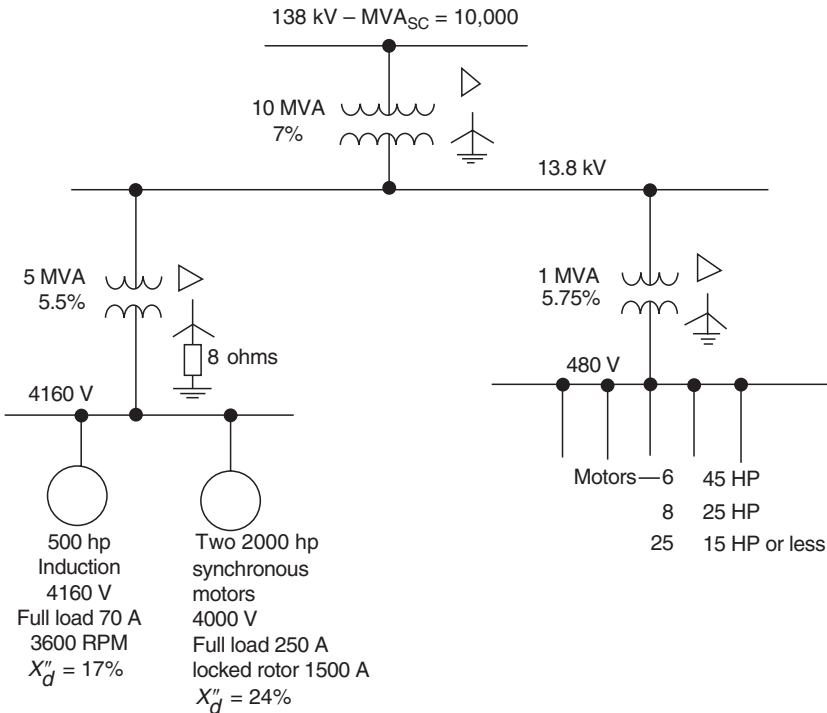

FIGURE P11.5

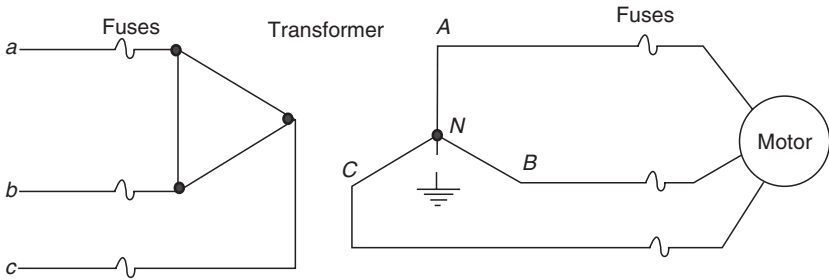

FIGURE P11.6

- b. What percent of the fault current does this induction and each of the two synchronous motors supply?
- c. Calculate the current flowing for a solid single-line-to-ground fault on the 4.16 kV bus.
- d. Select CT ratios and instantaneous overcurrent relay settings for protecting the motors for both phase and ground faults.

11.6 A fully loaded motor is connected to a supply source through a transformer as shown in Figure P11.6. The phase sequence is different on the two sides. Assume that the positive sequence current into the motor does not change after the fuse operations.

- a. For phase *b* fuse open on the source side, plot the sequence and total currents existing on both sides of the transformer. With one per unit positive sequence current, determine the magnitudes of the phase currents on both sides.
- b. Repeat part a with all source side fuses in service but with the phase *A* fuse on the motor side open.
- c. What effect does grounding the transformer neutral have?

CHAPTER 12

12.1 The 12.5 kV distribution feeder (Figure P12.1) has two taps. One is protected by three oil circuit reclosers with 70/140 A coils set as in Table P12.1. The other tap is a single-phase circuit protected by one 30 A fuse operating as shown in Table P12.2. The data for the 46 kV fuse is in Table P12.3. The phase and ground relays are very inverse time overcurrent with instantaneous units. Their time–overcurrent characteristics are shown in the typical curves of P12.11. Fault currents are in amperes at 12.5 kV.

- a. Determine the 46 kV fuse time–current characteristics in terms of 12.5 kVA for 12.5 kV three-phase, phase-to-phase and phase-to-ground faults. Draw these high-side fuse curves along with the

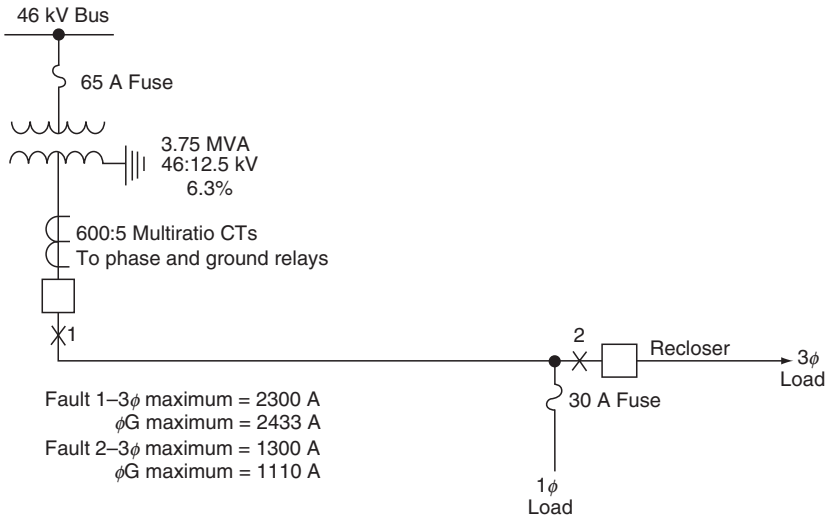

FIGURE P12.1

recloser and 30 A fuse curves on time–current log paper, such as K & E 48 5257, with 12.5 kVA as the abscissa and time in seconds as the ordinate.

TABLE P12.1
Circuit Reclosers

Current (A)	Time (sec)
140	20
185	10
200	7.5
275	5
320	4
400	3
480	2
600	1
650	0.8
720	0.7
800	0.6
900	0.5
1200	0.4
1600	0.3
2200	0.25

TABLE P12.2
30 A Fuse

Approximate by a 120° line
 passing through 1000 A at
 0.06 sec for the minimum melt curve
 0.11 sec for the maximum clearing curve

- b. Select a suitable ratio for the current transformers to the phase and ground relays.
 - c. Set and coordinate the phase and ground relays. Provide a minimum 0.2 sec coordination interval between the recloser and the relays, and a minimum 0.5 sec between the 46 kV fuse and the relays. Specify the time–overcurrent relay tap selected (available taps are 1-1.2-1.5-2-2.5-3-3.5-4-5-6-7-8-10), the time dial, and the instantaneous current pickup for both phase and ground relays. Plot the coordination on the curve of part 1.
- 12.2** In the loop system of [Figure 12.4](#), set and coordinate the phase overcurrent type relays around the loop in the counterclockwise direction for breakers 4, 6, and 9. Use criteria and the settings for the other relays involved from the example in the text.
- 12.3** Apply and set phase-instantaneous relays where they are applicable for the breakers 4, 6, and 9 in the system of [Figure 12.4](#).
- 12.4** A 12/16/20 MVA transformer is connected to a 115 kV source through a high-side 125E fuse and through a low side recloser to supply a 12.5 kV feeder. The transformer is delta-connected on the high side and solidly wye-grounded on the low side. The total reactance to the 12.5 kV bus is $X_2 = X_2 = 0.63$ per unit, $X_0 = 0.60$ per unit on 100 MVA. The lines from the 12.5 kV bus have a positive sequence impedance of 0.82 Ω /mile and a zero sequence impedance of 2.51 Ω /mile. Ignore the line angle in this problem.

TABLE P12.3
65 A Fuse, Minimum Melt

46 kV (A)	Time (sec)
130	300
260	10
500	1
1500	0.1

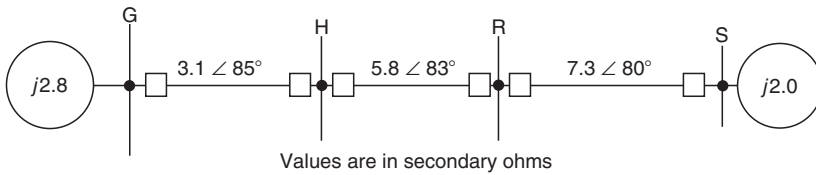

FIGURE P12.5

As a result of a problem it is necessary to operate temporarily with the low side recloser bypassed. Determine how many miles out on the line can be protected by the high-side fuse for solid line-to-ground faults. The minimum current to open the fuse is 300Ω .

12.5

- Apply and set distance-type relays at Stations H and R for the protection of line HR in the system in Figure P12.5. Set zone 1 units for 90% of the protected line, zone 2 to reach 50% into the next line section beyond the protected line, and zone 3 for 120% of the next line section.
- Plot this system on an R - X diagram with the origin at bus H. Plot the relay settings of part 1 using mho-type characteristics. The mathematical formula for a circle through the origin or relay location is where Z_s is the relay setting at 75° :

$$Z = \frac{1}{2}(Z_s - Z_s \angle \phi).$$

The first term is the offset from the origin at 75° and the second term is the radius. This when ϕ is 75° , $Z = 0$, the relay location; when ϕ is 255° , $Z = Z_s$ the forward reach.

- What is the maximum load in MVA at 87% pf. that can be carried over line HR without the distance relays operating? Assume that the voltage transformer ratio $R_V = 1000$ and the current transformer ratio $R_C = 80$.

12.6

- Apply and set distance relays for line HR as in Problem 12.5 except set the zone 3 unit in the reverse direction to reach 150% of the line section behind the relay.
- Plot these settings (zone 1 and 2 as in Problem 12.5) and zone 3 as given earlier on the R - X diagram with the origin at bus H.
- For this application, what is the maximum load in MVA at 87% pf. that can be carried over line HR without the distance relays operation? $R_V = 1000$ and $R_C = 80$.

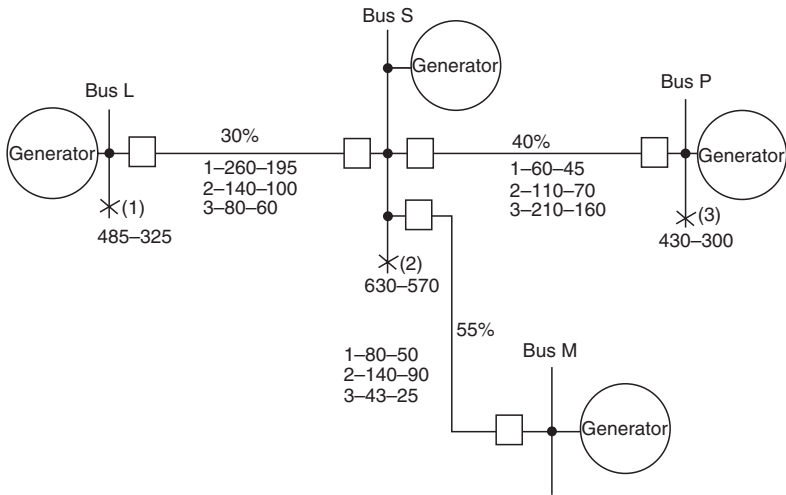
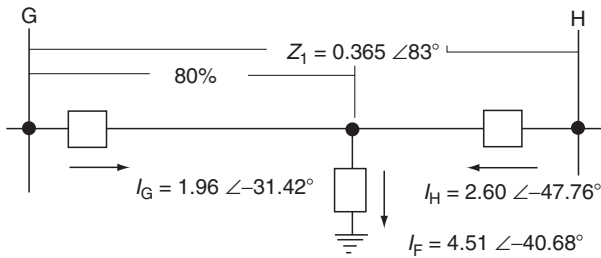

FIGURE P12.7

- 12.7** The line impedance values for the system in Figure P12.7 are in percent on a 100 MVA, 161 kV base. The fault values are in MVA at 161 kV for three-phase faults at the buses as indicated. The first value is for maximum conditions, and the second for minimum conditions.
- the zone 2 distance relay at station M is set for 70% impedance reach for the protection of line MS and into the lines SL and SP. The zone 3 distance relay is set for 100% impedance also into the line MS and the lines SL and SP. Determine the apparent impedance seen by these units at M under the maximum and minimum operation.
 - What percentage of the lines SL and SP are protected during these two operating conditions.
 - Determine the maximum load in MVA at 87% pf. that can be transmitted over line MS without operating the distance relays set as in part 2. Assume that the voltage transformer ratio $R_v = 1400$ and the current transformer ratio $R_c = 100$. Assume that the distance relay mho characteristic has a circle angle of 75° .
- 12.8** The 60 mile, 115 kV line GH (Figure P12.8) is operating with the voltages at each end 30° out of phase when a three-phase fault occurs at 80% of the distance from bus G. This fault has 12Ω arc resistance. The currents flowing to the fault are as shown and are in per unit at 100 MVA, 115 kV.
- Determine the apparent impedance seen by the distance relays at G for this fault.



All values in per unit on 100 MVA, 115 kV.

FIGURE P12.8

- Determine if the zone 1 mho unit at G set for 90% of the line GH can operate on this fault. Assume that the angle of the mho characteristic (Figure 6.12b) is 75° .
- Determine the apparent impedance seen by the distance relays at H for this fault.
- Determine if the zone 1 mho unit at H set for 90% of the line GH can operate for this fault. Assume that the angle of the mho characteristic is 75° .
- Describe how this three-phase fault can be cleared by the line distance relays.

12.9 The 40 MVA transformer bank (Figure P12.9) has tap changing under load (TCUL) with low voltage $\pm 10\%$ taps. The reactances at the high-, mid-, and low-voltage taps are 7.6% at 38 kV, 8% at 34.5 kV, and 8.5% at 31 kV respectively. This bank is connected directly to a 115 kV transmission line without a high-side breaker. There are no 115 kV voltage or current transformers available at G. To provide phase distance line protection, the relays must be set to

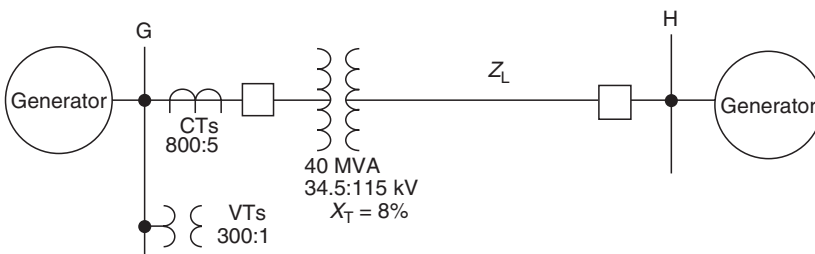

FIGURE P12.9

look through the transformer into the line. Assume that any phase shift through the transformer does not change the relay reach by either the connections or relay design.

- Set zone 1 phase distance relays at G for a 12 mile line GH where $Z_L = 10 \angle 80^\circ \Omega$. Note that it is necessary to determine which transformer bank tap gives the lowest value of ohms to bus H as viewed from bus G to prevent the relays from over-reaching bus H as taps are changed. Set zone 1 for $99\%X_T + 90\%Z_L$.
- With this setting of part 1, what percent of the line is protected by zone 1?
- What percent of the line will be protected when the other taps are in service with the setting of part 1?
- In view of the preceding analysis, what recommendations would you make for line protection?

12.10 Repeat Problem 12.9 but with a 50 mile, 115 kV line where $Z_L = 40 \angle 80^\circ \Omega$. Compare the protection for the 12 mile line or Problem 12.9 with the protection for the 50 mile line.

12.11 Ground directional overcurrent relays are to be applied to the 69 kV and 138 kV breakers for the protection of the 138 kV line that includes the autotransformer as shown in Figure P12.11. To determine the best method of directional sensing fault $I_1 = I_2$ and I_0 currents and V_2 and V_0 voltages are indicated for the three different line-to-ground faults.

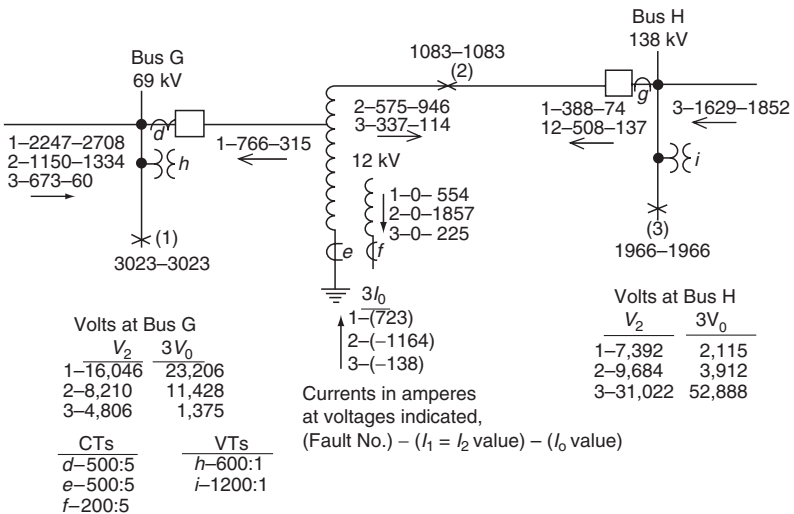

FIGURE P12.11.A

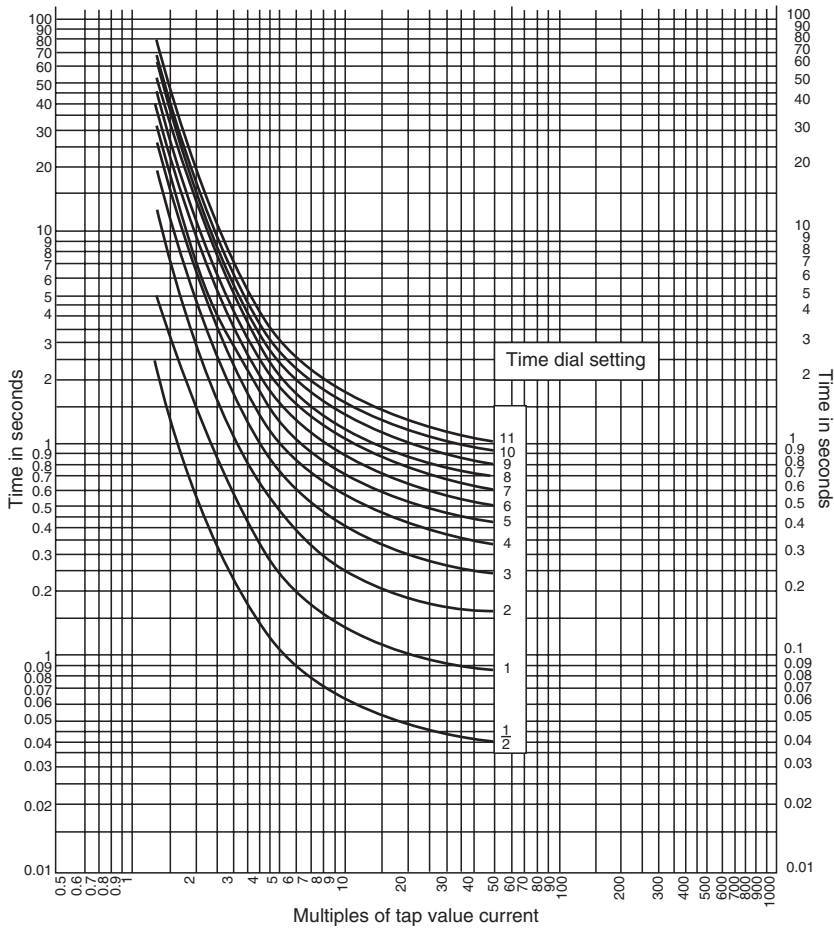

FIGURE P12.11.B

- Determine the secondary (relay) quantities that could be used to polarize and operate ground relays at both the G and H terminals.
- Make recommendations for the preferred method to polarize and operate the ground relays at G and H.

CHAPTER 14

14.1 For the system of Problem P12.5:

- Draw the locus of the surge ohms seen by the relays at H and R as the generators at the two ends of the system slip a pole. Assume

- that the two generator voltages remain equal in magnitude throughout the swing. Locate the 60° , 90° , 120° , 180° , 240° , 270° , and 300° points.
- b. What is the magnitude of impedance as seen from bus H and from bus R for a 120° swing?
 - c. With the distance settings applied in Problem 12.5, determine which distance relays will operate on the swing and at what swing angle this will occur.
 - d. Repeat part c but with the distance settings as applied in Problem 12.6.